

Service Manual



RSA2203A & RSA2208A 3 GHz & 8 GHz Real-Time Spectrum Analyzers 071-1337-00

This document applies to firmware version 2.0 and above.

Warning

The servicing instructions are for use by qualified personnel only. To avoid personal injury, do not perform any servicing unless you are qualified to do so. Refer to all safety summaries prior to performing service.

www.tektronix.com

Copyright © Tektronix Japan, Ltd. All rights reserved.

Copyright © Tektronix, Inc. All rights reserved.

Tektronix products are covered by U.S. and foreign patents, issued and pending. Information in this publication supercedes that in all previously published material. Specifications and price change privileges reserved.

Tektronix Japan, Ltd., Shinagawa Intercity Building B 6th Floor, 2-15-2 Konan, Minato-ku, Tokyo 108-6106 Japan
Tektronix, Inc., P.O. Box 500, Beaverton, OR 97077

TEKTRONIX and TEK are registered trademarks of Tektronix, Inc.

Windows and Windows 98 are trademarks of Microsoft Corporation.

WARRANTY

Tektronix warrants that the products that it manufactures and sells will be free from defects in materials and workmanship for a period of one (1) year from the date of shipment. If a product proves defective during this warranty period, Tektronix, at its option, either will repair the defective product without charge for parts and labor, or will provide a replacement in exchange for the defective product.

In order to obtain service under this warranty, Customer must notify Tektronix of the defect before the expiration of the warranty period and make suitable arrangements for the performance of service. Customer shall be responsible for packaging and shipping the defective product to the service center designated by Tektronix, with shipping charges prepaid. Tektronix shall pay for the return of the product to Customer if the shipment is to a location within the country in which the Tektronix service center is located. Customer shall be responsible for paying all shipping charges, duties, taxes, and any other charges for products returned to any other locations.

This warranty shall not apply to any defect, failure or damage caused by improper use or improper or inadequate maintenance and care. Tektronix shall not be obligated to furnish service under this warranty a) to repair damage resulting from attempts by personnel other than Tektronix representatives to install, repair or service the product; b) to repair damage resulting from improper use or connection to incompatible equipment; c) to repair any damage or malfunction caused by the use of non-Tektronix supplies; or d) to service a product that has been modified or integrated with other products when the effect of such modification or integration increases the time or difficulty of servicing the product.

THIS WARRANTY IS GIVEN BY TEKTRONIX IN LIEU OF ANY OTHER WARRANTIES, EXPRESS OR IMPLIED. TEKTRONIX AND ITS VENDORS DISCLAIM ANY IMPLIED WARRANTIES OF MERCHANTABILITY OR FITNESS FOR A PARTICULAR PURPOSE. TEKTRONIX' RESPONSIBILITY TO REPAIR OR REPLACE DEFECTIVE PRODUCTS IS THE SOLE AND EXCLUSIVE REMEDY PROVIDED TO THE CUSTOMER FOR BREACH OF THIS WARRANTY. TEKTRONIX AND ITS VENDORS WILL NOT BE LIABLE FOR ANY INDIRECT, SPECIAL, INCIDENTAL, OR CONSEQUENTIAL DAMAGES IRRESPECTIVE OF WHETHER TEKTRONIX OR THE VENDOR HAS ADVANCE NOTICE OF THE POSSIBILITY OF SUCH DAMAGES.

Table of Contents

General Safety Summary	xi
Service Safety Summary	xiii
Preface	xv
Manual Structure	xv
Manual Conventions	xvi
Finding Other Information	xvi
Contacting Tektronix	xvii
Introduction	xix
Performance Check Interval	xix
Strategy for Servicing	xix

Specifications

Product Overview	1-1
Features	1-1
Application	1-2
Difference between RSA2203A and RSA2208A	1-2
Real-Time Analysis	1-3
Architecture	1-6
Specifications	1-9
Performance Conditions	1-9
Electrical Characteristics	1-10
Physical Characteristics	1-21
Environmental Characteristics	1-21

Operating Information

Installation	2-1
Supplying Operating Power	2-1
Operating Environment	2-3
Applying Power	2-4
Setting Up the Stand	2-7
Powering Off the Analyzer	2-8
Restart	2-9
Repackaging Instructions	2-10
Installed Options	2-10
Operating Instructions	2-11
Preparations	2-12
Displaying Spectrum	2-16
Using Markers and Peak Search	2-23
Using Averaging and Comparison Displays	2-28
Displaying a Spectrogram	2-31
Spectrum Analysis	2-34
Modulation Analysis	2-38
Using Windows 98	2-46
Turning Off the Power	2-48

Theory of Operation

RF Input Circuit	3-1
RF3 Module	3-2
RF2 Module	3-2
RF5 Module	3-3
RF4 Module	3-3
A10 A/D Board	3-4
A41 SRAM Board	3-4
Power Supply Circuit	3-5
Standby Power and On/Standby Switch	3-5
A50 Mother Board	3-6
A60 Front Key Board	3-6
A62 Front Connection Board	3-6

Performance Verification

Conventions	4-2
Brief Procedures	4-3
Functional Check	4-4
Diagnostics	4-8
Performance Tests	4-9
Prerequisites	4-10
Equipment Required	4-10
Auto Tests	4-12
Manual Tests	4-20
Test Record	4-48

Adjustment Procedures

Requirements for Performance	5-1
Equipment Required	5-1
Preparation	5-3
Self Calibration	5-9
Auto Calibration	5-13
Reference Oscillator Frequency Adjustment	5-16
Reconfiguration of RF Modules	5-18

Maintenance

Related Maintenance Procedures	6-1
Preparation	6-2
Inspection and Cleaning	6-4
Removal and Installation Procedures	6-7
Preparation	6-7
Access Procedure	6-21
Procedures for External Modules	6-22
Procedures for RF Modules	6-27
Procedures for CPU Board and Disk Modules	6-31
Procedures for Mother Board and its Daughter Boards	6-36
Procedures for Power Supply Modules on the Instrument Bottom	6-42
Procedures for RF1 Modules on the Instrument Bottom	6-47
Procedures for Front Panel Modules	6-54
Procedures for Chassis Modules	6-60
Troubleshooting	6-65
Troubleshooting Procedure	6-65
Symptoms and Faulty Modules	6-78
Notes for Changing Modules or Parts	6-79

Options

Options and Accessories	7-1
Options	7-1
Standard Accessories	7-3
Optional Accessories	7-3

Electrical Parts List

Diagrams

Mechanical Parts List

Replaceable Parts	10-1
Parts Ordering Information	10-1
Using the Replaceable Parts List	10-2

Figure 2–28: Channel power measurement	2–35
Figure 2–29: Channel power measurement (Channel Bandwidth = 40 kHz)	2–36
Figure 2–30: Carrier frequency measurement	2–37
Figure 2–31: MODE keys	2–38
Figure 2–32: AM signal measurement	2–39
Figure 2–33: Analysis range settings	2–41
Figure 2–34: Frame and block	2–42
Figure 2–35: Changing the acquisition length	2–43
Figure 2–36: Single view display	2–44
Figure 2–37: Scale settings	2–45
Figure 2–38: USB ports (side panel)	2–46
Figure 2–39: Displaying Windows 98 desktop	2–47
Figure 4–1: Spectrum of the calibration signal (50 MHz, –20 dBm) .	4–5
Figure 4–2: Setup display	4–6
Figure 4–3: Reference level setting and A/D overflow indicator	4–7
Figure 4–4: Spectrogram display	4–7
Figure 4–5: Diagnostic screen	4–8
Figure 4–6: Initial test hookup	4–12
Figure 4–7: Initial test hookup	4–21
Figure 4–8: Initial hookup for setting up the power meter and sensor	4–22
Figure 4–9: Hookup for calibrating the power sensor	4–23
Figure 4–10: Hookup for setting the signal generator output	4–23
Figure 4–11: Hookup for checking the absolute amplitude accuracy	4–24
Figure 4–12: Initial test hookup	4–26
Figure 4–13: Initial test hookup	4–29
Figure 4–14: Initial test hookup	4–32
Figure 4–15: Initial test hookup	4–35
Figure 4–16: Initial test hookup	4–39
Figure 4–17: Initial test hookup	4–41
Figure 4–18: Initial test hookup	4–44
Figure 5–1: Hookup for storing the cal factors in the power meter ..	5–4
Figure 5–2: Initial test hookup	5–7
Figure 5–3: Hookup for calibrating the power sensor	5–8
Figure 5–4: UNCAL display	5–9
Figure 5–5: Calibration menu	5–10

Figure 5-6: Center offset	5-11
Figure 5-7: DC offset	5-12
Figure 5-8: Initial test hookup	5-13
Figure 5-9: Initial test hookup	5-16
Figure 5-10: R232 location (top view of the card cage)	5-17
Figure 5-11: Test hookup	5-19
Figure 5-12: Test hookup	5-20
Figure 6-1: Analyzer orientation	6-11
Figure 6-2: External modules	6-12
Figure 6-3: RF modules	6-13
Figure 6-4: CPU board and disk modules	6-14
Figure 6-5: Mother board and its daughter boards	6-15
Figure 6-6: Bottom modules – Power supply	6-16
Figure 6-7: Bottom modules – RF1 (RSA2203A)	6-17
Figure 6-8: Bottom modules – RF1 (RSA2208A)	6-18
Figure 6-9: Front panel modules	6-19
Figure 6-10: Chassis modules	6-20
Figure 6-11: Guide to removal procedures	6-21
Figure 6-12: Line cord and cabinet removal	6-23
Figure 6-13: Front cushion removal	6-24
Figure 6-14: Cabinet Modules Removal	6-26
Figure 6-15: RF modules removal	6-28
Figure 6-16: CPU board removal	6-32
Figure 6-17: Disk module removal	6-34
Figure 6-18: A10 A/D board removal	6-37
Figure 6-19: Daughter boards removal	6-39
Figure 6-20: Mother board removal	6-41
Figure 6-21: Power supply 1 and 2 removal	6-43
Figure 6-22: Power supply modules removal	6-45
Figure 6-23: RF1 modules removal – 1	6-48
Figure 6-24: RF1 modules removal – 2 (RSA2203A)	6-50
Figure 6-25: RF1 modules removal – 2 (RSA2208A)	6-53
Figure 6-26: Front panel assembly removal	6-55
Figure 6-27: Front panel modules removal	6-56
Figure 6-28: LCD display removal	6-59
Figure 6-29: Fan and side panel removal	6-61
Figure 6-30: Board guide bracket removal	6-62
Figure 6-31: Rear panel modules	6-64

Figure 6–32: Troubleshooting procedure 1 — Power supply system .	6–66
Figure 6–33: Troubleshooting procedure 2 — Display and CPU system	6–67
Figure 6–34: Troubleshooting procedure 3 — Signal path	6–68
Figure 6–35: Top view for cable interconnection	6–73
Figure 6–36: Bottom view for cable interconnection (RSA2203A) . . .	6–74
Figure 6–37: Bottom view for cable interconnection (RSA2208A) . . .	6–75
Figure 6–38: A70 DC power supply board	6–77
Figure 9–1: Block diagram	9–3
Figure 9–2: Interconnect diagram (RSA2203A)	9–5
Figure 9–3: Interconnect diagram (RSA2208A)	9–7
Figure 10–1: External modules	10–5
Figure 10–2: Front-panel assembly – 1	10–7
Figure 10–3: Front-panel assembly – 2	10–9
Figure 10–4: RF modules	10–11
Figure 10–5: Mother board and its daughter boards – 1	10–13
Figure 10–6: Mother board and its daughter boards – 2	10–15
Figure 10–7: Disk modules	10–17
Figure 10–8: Bottom modules – Power supply	10–19
Figure 10–9: Bottom modules – RF1 (RSA2203A)	10–21
Figure 10–10: Bottom modules – RF1 (RSA2208A)	10–23
Figure 10–11: Chassis modules – 1	10–25
Figure 10–12: Chassis modules – 2	10–27
Figure 10–13: Rackmount – 1	10–29
Figure 10–14: Rackmount – 2	10–31

List of Tables

Table 1–1: Frequency	1–10
Table 1–2: Spectrum purity	1–11
Table 1–3: Noise sideband	1–11
Table 1–4: Input	1–12
Table 1–5: Amplitude	1–13
Table 1–6: Dynamic range	1–13
Table 1–7: Spurious response	1–14
Table 1–8: Acquisition	1–15
Table 1–9: Sampling rate	1–15
Table 1–10: Frame time	1–16
Table 1–11: RBW (Resolution Bandwidth)	1–17
Table 1–12: Analog demodulation	1–18
Table 1–13: Trigger	1–18
Table 1–14: Measurement function	1–18
Table 1–15: Display	1–19
Table 1–16: Marker, trace, and display line	1–19
Table 1–17: Controller and interface	1–19
Table 1–18: Power requirements	1–20
Table 1–19: Power connector	1–20
Table 1–20: Physical characteristics	1–21
Table 1–21: Environmental characteristics	1–21
Table 1–22: Certifications and compliances	1–22
Table 2–1: Power-cord conductor identification	2–1
Table 2–2: Power cord identification	2–2
Table 4–1: Span and RBW	4–6
Table 4–2: Internal diagnostic program	4–8
Table 4–3: Test equipment	4–10
Table 4–4: Spurious measurement	4–40
Table 5–1: Test equipment	5–2
Table 6–1: Relative susceptibility to static-discharge damage	6–3
Table 6–2: External inspection check list	6–5
Table 6–3: Internal inspection check list	6–6

Table 6-4: Summary of procedures	6-9
Table 6-5: Tools required for module removal	6-10
Table 6-6: Normal supply voltages	6-76
Table 6-7: Test point voltages on A70	6-77
Table 6-8: Symptoms and faulty modules	6-78
Table 7-1: Power cord identification	7-2
Table 7-2: Standard accessories	7-3
Table 7-3: Optional accessories	7-3

General Safety Summary

Review the following safety precautions to avoid injury and prevent damage to this product or any products connected to it. To avoid potential hazards, use this product only as specified.

Only qualified personnel should perform service procedures.

To Avoid Fire or Personal Injury

Use Proper Power Cord. Use only the power cord specified for this product and certified for the country of use.

Ground the Product. This product is grounded through the grounding conductor of the power cord. To avoid electric shock, the grounding conductor must be connected to earth ground. Before making connections to the input or output terminals of the product, ensure that the product is properly grounded.

Observe All Terminal Ratings. To avoid fire or shock hazard, observe all ratings and markings on the product. Consult the product manual for further ratings information before making connections to the product.

Do Not Operate Without Covers. Do not operate this product with covers or panels removed.

Avoid Exposed Circuitry. Do not touch exposed connections and components when power is present.

Do Not Operate With Suspected Failures. If you suspect there is damage to this product, have it inspected by qualified service personnel.

Do Not Operate in Wet/Damp Conditions.

Do Not Operate in an Explosive Atmosphere.

Provide Proper Ventilation. Refer to the manual's installation instructions for details on installing the product so it has proper ventilation.

Symbols and Terms

Terms in this Manual. These terms may appear in this manual:



WARNING. Warning statements identify conditions or practices that could result in injury or loss of life.



CAUTION. Caution statements identify conditions or practices that could result in damage to this product or other property.

Terms on the Product. These terms may appear on the product:

DANGER indicates an injury hazard immediately accessible as you read the marking.

WARNING indicates an injury hazard not immediately accessible as you read the marking.

CAUTION indicates a hazard to property including the product.

Symbols on the Product. The following symbols may appear on the product:



WARNING
High Voltage



Protective Ground
(Earth) Terminal



CAUTION
Refer to Manual

Service Safety Summary

Only qualified personnel should perform service procedures. Read this *Service Safety Summary* and the *General Safety Summary* before performing any service procedures.

Do Not Service Alone. Do not perform internal service or adjustments of this product unless another person capable of rendering first aid and resuscitation is present.

Disconnect Power. To avoid electric shock, switch off the instrument power, and then disconnect the power cord from the mains power.

Use Care When Servicing With Power On. Dangerous voltages or currents may exist in this product. Disconnect power, remove battery (if applicable), and disconnect test leads before removing protective panels, soldering, or replacing components.

To avoid electric shock, do not touch exposed connections.

Preface

This is the service manual for the RSA2203A and RSA2208A Real-Time Spectrum Analyzers. The manual contains information needed to service the analyzer to the module level.

Manual Structure

This manual is divided into sections, such as *Specifications* and *Theory of Operation*. Further, some sections are divided into subsections, such as *Product Description* and *Removal and Installation Procedures*.

Sections containing procedures also contain introductions to those procedures. Be sure to read these introductions because they provide information needed to do the service correctly and efficiently. The manual section name and a brief description of each is given below.

- *Specifications* contains a description of the analyzer and the applicable characteristics.
- *Operating Information* includes general information and operating instructions.
- *Theory of Operation* contains circuit descriptions that support service to the module level.
- *Performance Verification* contains procedures for confirming that the analyzer functions properly and meets warranted limits.
- *Adjustment Procedures* contains procedures for adjusting the analyzer to meet warranted limits.
- *Maintenance* contains information and procedures for performing preventive and corrective maintenance of the analyzer. These instructions include cleaning, module removal and installation, and fault isolation to the module.
- *Options* contains information on servicing factory-installed options.
- *Electrical Parts List* contains a statement referring you to *Mechanical Parts List*, where both electrical and mechanical modules are listed.
- *Diagrams* contains a block diagram and an interconnection diagram.
- *Mechanical Parts List* includes a table of all replaceable modules, their descriptions, and their Tektronix part numbers.

Manual Conventions

This manual uses certain conventions that you should become familiar with.

Some sections of the manual contain procedures for you to perform. To keep those instructions clear and consistent, this manual uses the following conventions:

- Names of front panel controls and menus appear in the same case (initial capitals, all uppercase, etc.) in the manual as is used on the analyzer front panel and menus. Front panel names are all upper-case letters; for example, SPAN, TRIG, and SELECT.
- Instruction steps are numbered unless there is only one step.

Modules

Throughout this manual, any replaceable component, assembly, or part of the analyzer is referred to generically as a module. In general, a module is an assembly (like a circuit board), rather than a component (like a resistor or an integrated circuit). Sometimes a single component is a module; for example, the chassis of the analyzer is a module.

Safety

Symbols and terms related to safety appear in the *Safety Summary* near the beginning of this manual.

Finding Other Information

Other documentation for the RSA2203A and RSA2208A analyzers includes:

- The *RSA2203A and RSA2208A User Manual* contains a tutorial to quickly describe how to operate the analyzer. It also includes an in-depth discussion on how to more completely use the analyzer features.
- The *RSA2203A and RSA2208A Programmer Manual* explains how to use the GPIB interface to remotely control the analyzer.

Contacting Tektronix

Phone	1-800-833-9200*
Address	Tektronix, Inc. Department or name (if known) 14200 SW Karl Braun Drive P.O. Box 500 Beaverton, OR 97077 USA
Web site	www.tektronix.com
Sales support	1-800-833-9200, select option 1*
Service support	1-800-833-9200, select option 2*
Technical support	Email: techsupport@tektronix.com 1-800-833-9200, select option 3* 6:00 a.m. – 5:00 p.m. Pacific time

* **This phone number is toll free in North America. After office hours, please leave a voice mail message. Outside North America, contact a Tektronix sales office or distributor; see the Tektronix web site for a list of offices.**

Introduction

This manual contains information needed to properly service the RSA2203A and RSA2208A Real-Time Spectrum Analyzers as well as general information critical to safe and effective servicing.

To prevent personal injury or damage to the analyzer, consider the following before attempting service:

- The procedures in this manual should be performed only by a qualified service person.
- Read the *General Safety Summary* and the *Service Safety Summary*, beginning on page xi.
- Read *Preparation for Use* in section 2, *Operating Information*.

When using this manual for servicing, be sure to follow all warnings, cautions, and notes.

Performance Check Interval

Generally, the performance check described in section 4, *Performance Verification*, should be done every 12 months. In addition, performance check is recommended after module replacement.

If the analyzer does not meet performance criteria, repair is necessary.

Strategy for Servicing

Throughout this manual, the term “module” refers to any field-replaceable component, assembly, or part of the analyzer.

This manual contains all the information needed for periodic maintenance of the analyzer. (Examples of such information are procedures for checking performance.)

Further, it contains all information for corrective maintenance down to the module level. To isolate a failure to a module, use the fault isolation procedures found in *Troubleshooting*, part of section 6, *Maintenance*. To remove and replace any failed module, follow the instructions in *Removal and Installation Procedures*, also part of section 6. After isolating a faulty module, replace it with a fully-tested module obtained from the factory. Section 10, *Mechanical Parts List*, contains part number and ordering information for all replaceable modules.

Specifications

Product Overview

The RSA2203A and RSA2208A are portable real-time spectrum analyzers with RF measurement capability up to 3 GHz (RSA2203A) and 8 GHz (RSA2208A). The real-time spectrum analyzer has a vastly different architecture from traditional tools, and is uniquely capable of capturing continuous, intermittent, or random signals with equal ease. The waveform and measurement results of data acquired seamlessly can be displayed in various formats such as frequency versus amplitude, time versus amplitude/frequency/phase, AM/FM/PM demodulation, and spectrogram containing three dimensional information of frequency, time, and amplitude/phase.

Features

- Measurement frequency range:
10 MHz to 3 GHz for RSA2203A; 10 MHz to 8 GHz for RSA2208A
DC to 20 MHz (Option 05)
- Measurement span: 100 Hz to 3 GHz
Vector span: 10 MHz
- Real-time analysis
- Spectrum analysis: power, ACPR, C/N, OBW, EBW, spurious
- Analog modulation analysis: AM, PM, FM
- Time characteristic analysis
- CCDF measurement
- Various displays of analysis results:
 - Spectrum display (frequency versus power)
 - Spectrogram display (frequency versus time versus power)
 - Time characteristic analysis display (IS-95 standard)
 - Analog demodulation display
(time versus modulation factor, phase, or frequency)
- 8.4 inch TFT color display and sturdy cabinet

Application

The RSA2203A and the RSA2208A can perform real-time analysis for the following purposes:

- Research and development of second and third generation communication instruments: 3GPP, W-CDMA, GSM, IS-95, T-53, PDC
- Research and development of Bluetooth communication instruments
- Analog modulation analysis
- Power measurement: power, noise, ACP, C/N, occupied bandwidth
- Variation analysis of PLL frequency:
 - Jitter in reference oscillator circuits of mobile phones
 - Localization of radio equipment
 - Hard disk readout jitter
- Analysis of momentary noise: mixed noise measurement, EMI measurement
- Multi-path measurement: measurement of electric wave environment
- Electric wave interference: radar interference
- Electric wave analysis: analysis of electric waves form foreign countries

Difference between RSA2203A and RSA2208A

The RSA2203A and the RSA2208A have the same functions except for their measurement frequency ranges:

RSA2203A 10 MHz to 3 GHz
RSA2208A 10 MHz to 8 GHz

Descriptions in this manual apply to both the RSA2203A and the RSA2208A unless otherwise noted.

Real-Time Analysis

This section explains real-time analysis with the comparison of conventional swept spectrum analyzer and real-time spectrum analyzer.

Conventional Swept Spectrum Analyzer

Figure 1–1 is a block diagram of the conventional swept spectrum analyzer. There are two RF input signals in this example. The RF signal is converted to IF (intermediate frequency) by the swept local oscillator. IF output goes through a bandpass filter, where resolution of the spectrum analyzer is defined.

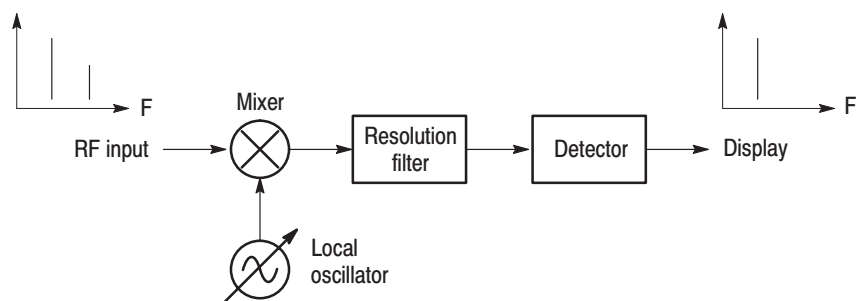

Figure 1–1: Concept of the swept spectrum analyzer

The filter is swept from F_{start} to F_{stop} . See Figure 1–2. Only signals within the filter bandwidth are observed at one point in time. Signal A is detected first and then signal B is detected and displayed.

NOTE. An intermittent signal, such as a burst phenomenon, will not be detected unless it is present at the exact moment that the filter is being swept past it.

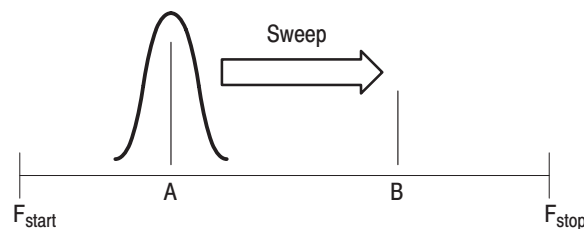

Figure 1–2: Sweep of resolution filter

Real-Time Spectrum Analyzer

The real-time spectrum analyzer is conceptually equipped with a series of bandpass filters as shown in Figure 1-3. Signals passing through those filters are concurrently observed and recorded continuously. Signals A and B are concurrently acquired and displayed as shown in Figure 1-4.

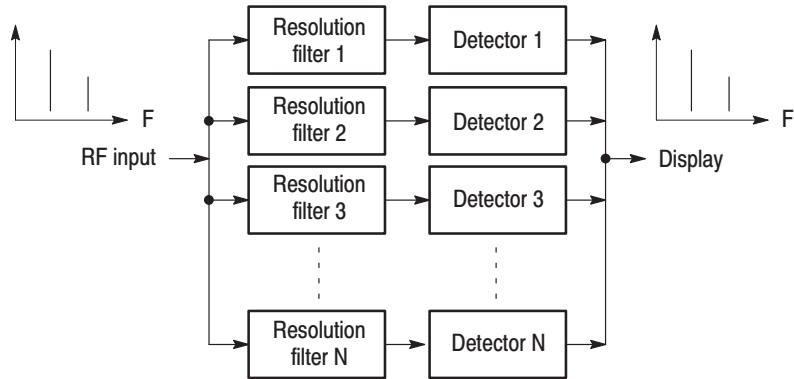

Figure 1-3: Concept of the real-time spectrum analyzer

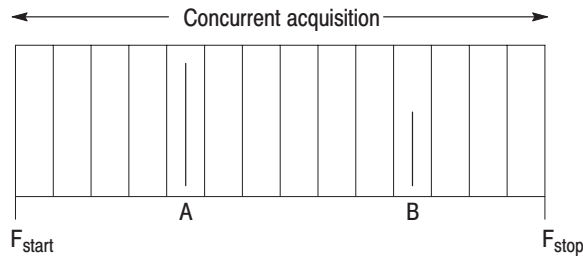

Figure 1-4: Concurrent acquisition

The method used to concurrently acquire signals in a certain frequency range is not bandpass filters, but FFT (Fast Fourier Transformation). The RSA2203A or RSA2208A first acquires a series of frames of data in the time domain, as shown in Figure 1–5, and then performs the FFT process for each frame. This method enables continuous analysis of spectra and ensures the capture of real-time phenomenon such as burst signals in digital mobile communication. The RSA2203A and the RSA2208A are equipped with a 51.2 MHz A/D converter to analyze the spectrum by single scanning for spans up to 10 MHz.

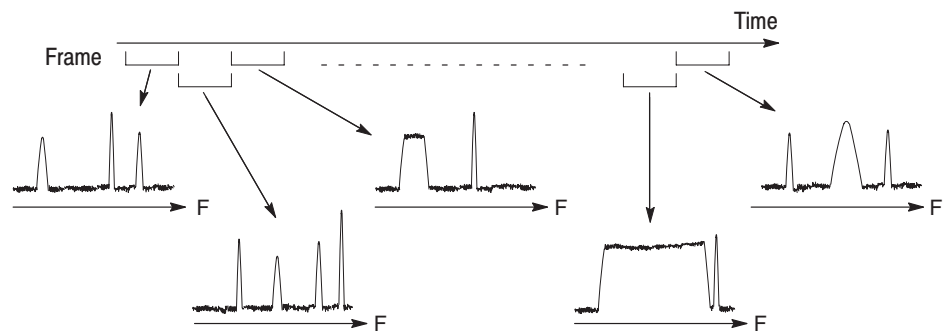

Figure 1–5: Frame acquisition

Architecture

Figure 1–6 shows the block diagram of the signal processing system.

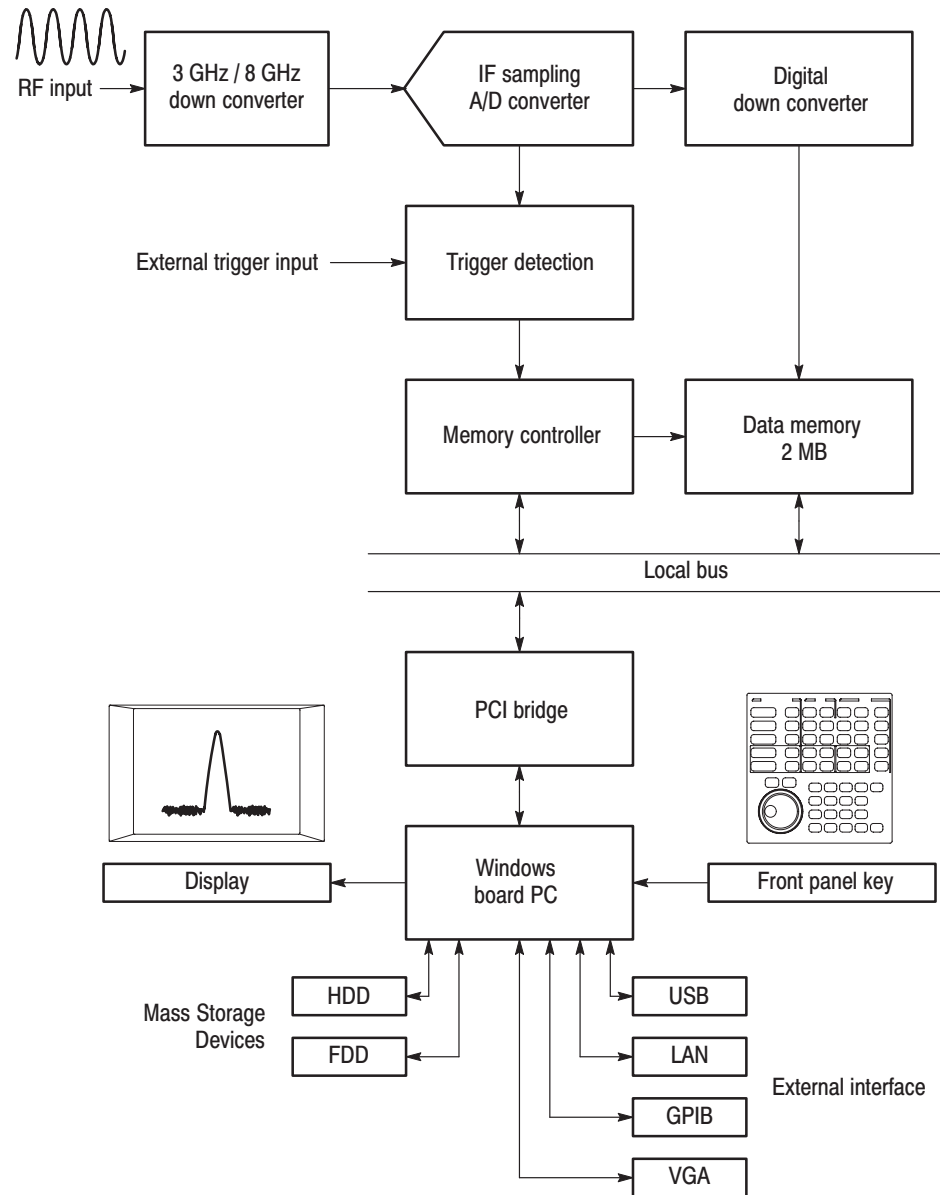

Figure 1–6: Block diagram

**3 GHz / 8 GHz
Down Converter**

Converts the RF signal, input through the front-panel INPUT connector, into a 20 MHz IF signal. This converter processes signals up to 3 GHz for RSA2203A and 8 GHz for RSA2208A by IF conversions in three stages. A 10 MHz oscillator provides a high-accuracy reference for all stages of IF conversion. The converter also adjusts signals for A/D conversion using a low-noise amplifier, fine-tuning attenuator, and anti-alias filter. The output signal from the down converter is sent to the IF sampling A/D converter described below.

IF Sampling A/D Converter

The IF analog output from the down converter enters the A/D converter through the fine-tuning attenuator, low-noise amplifier, and anti-alias filter, to be converted into a digital signal. The sampling rate of the A/D converter is 51.2 MHz with a resolution of 14 bits.

Digital Down Converter

The digital down converter splits the real signal from the A/D converter into complex (I and Q) components and limits the frequency span of the resulting signal.

The down converter performs span and center frequency fine-tuning. This converter consists of two primary stages. In the baseband (Option 05), the first stage converts a 0 to 20 MHz real signal into a complex signal of ± 10 MHz. The second stage converts frequency to set any center frequency.

A decimating filter between stages changes the span by effectively reducing the sampling rate. A 503 tap FIR filter and four stage comb filter allows extremely accurate filtering with minimal spurious emissions.

The data streams from the digital down converter are then divided into frames and saved in data memory.

Data Memory

A high-speed 2 MB standard SDRAM stores spectrum data. For each data point, I and Q data use 2 bytes. This memory can store 500 frames for 1 waveform = 1024 points of analysis. The memory is accessed from the system controller through the ISA/PCI bridge.

Windows Board PC

The system controller board has an Intel Pentium III CPU. It runs on Windows 98, and controls menu operation from the front panel keys. It is equipped with a 10 GB hard disk and 3.5 inch disk drive to store data and settings. Waveforms, menus, and measurement results are shown on the color display, which uses an 8.4 inch XGA TFT-LCD module.

The standard analyzer has the following external interfaces:

- USB (for mouse, keyboard, and/or printer)
- LAN (Ethernet 10/100BASE-T)
- GPIB
- VGA (for an external monitor)

Specifications

This section contains the RSA2203A and RSA2208A Real-Time Spectrum Analyzers specifications. All specifications are guaranteed unless labeled *Typical*. Typical specifications are provided for your convenience.

NOTE. *In these tables, those warranted characteristics that are checked in the Performance Verification appear with the ✓ symbol in the Characteristics column.*

Performance Conditions

The performance limits in this specification are valid with these conditions:

- The analyzer must have been calibrated and adjusted at an ambient temperature between +20 °C and +30 °C.
- The analyzer must be in an environment with temperature, altitude, humidity, and vibration within the operating limits described in these specifications.
- The analyzer must have had a warm-up period of at least 20 minutes.

Electrical Characteristics

Table 1-1: Frequency

Characteristics	Description
Measurement frequency	
Frequency range	RF: 10 MHz to 3 GHz (RSA2203A) RF1: 10 MHz to 3.5 GHz (RSA2208A) RF2: 3.5 GHz to 6.5 GHz (RSA2208A) RF3: 5 GHz to 8 GHz (RSA2208A) Baseband: DC to 20 MHz (Option 05)
Center frequency setting resolution	0.1 Hz
✓ Frequency marker readout accuracy (RF, RF1 to 3, and baseband (Option 05))	$\pm(\text{RE} \times \text{MF} + 0.001 \times \text{Span} + \text{RFM})$ Hz RE: Reference frequency error; MF: Marker frequency; RFM: Residual FM
At specified frequency: Standard	RF/RF1, Frequency = 2 GHz, Span = 1 MHz Marker: ± 5 kHz; Carrier frequency measurement: ± 4 kHz RF2, Frequency = 5 GHz, Span = 1 MHz (RSA2208A only) Marker: ± 11 kHz; Carrier frequency measurement: ± 10 kHz RF3, Frequency = 7 GHz, Span = 1 MHz (RSA2208A only) Marker: ± 15 kHz; Carrier frequency measurement: ± 14 kHz
At specified frequency: Option 10	RF/RF1, Frequency = 2 GHz, Span = 1 MHz Marker: ± 1.2 kHz; Carrier frequency measurement: ± 210 Hz RF2, Frequency = 5 GHz, Span = 1 MHz (RSA2208A only) Marker: ± 1.5 kHz; Carrier frequency measurement: ± 510 Hz RF3, Frequency = 7 GHz, Span = 1 MHz (RSA2208A only) Marker: ± 1.7 kHz; Carrier frequency measurement: ± 710 Hz
At specified frequency: Option 05	Frequency = 10 MHz, Span = 1 MHz, without Option 10 Marker: ± 1 kHz; Carrier frequency measurement: ± 50 Hz Frequency = 10 MHz, Span = 1 MHz, with Option 10 Marker: ± 1 kHz; Carrier frequency measurement: ± 1.2 Hz
Residual FM (<i>Typical</i>)	10 Hz p-p (standard); 2 Hz p-p (Option 10)
Span accuracy	± 1 bin
RBW filter bandwidth accuracy	0.1%
Reference frequency	
Aging per year (<i>Typical</i>)	2×10^{-6} ; 1×10^{-7} (Option 10)
Temperature drift (10 to 40 °C)	2×10^{-6} ; 1×10^{-7} (Option 10)
Total frequency error (within one year after calibration)	4×10^{-6} ; 2×10^{-7} (Option 10)
Reference output level	>0 dBm
External reference input	10 MHz, -10 to +6 dBm, Spurious level <-80 dBc within 100 kHz offset

Table 1-2: Spectrum purity

Characteristics	Description
✓ Spectrum purity (Frequency = 1500 MHz)	
Carrier offset = 10 kHz, Span = 100 kHz	100 dBc/Hz
Carrier offset = 100 kHz, Span = 1 MHz	105 dBc/Hz
Carrier offset = 1 MHz, Span = 5 MHz	125 dBc/Hz

Table 1-3: Noise sideband

Characteristics	Description	
	Noise sideband	Offset
Frequency = 1000 MHz	-99 dBc/Hz -105 dBc/Hz -105 dBc/Hz -105 dBc/Hz -112 dBc/Hz -130 dBc/Hz -132 dBc/Hz -133 dBc/Hz	1 kHz 10 kHz 20 kHz 30 kHz 100 kHz 1 MHz 5 MHz 7 MHz
Frequency = 2000 MHz	-95 dBc/Hz -104 dBc/Hz -105 dBc/Hz -105 dBc/Hz -112 dBc/Hz -130 dBc/Hz -132 dBc/Hz -132 dBc/Hz	1 kHz 10 kHz 20 kHz 30 kHz 100 kHz 1 MHz 5 MHz 7 MHz
Frequency = 6000 MHz (RSA2208A only)	-87 dBc/Hz -103 dBc/Hz -103 dBc/Hz -105 dBc/Hz -111 dBc/Hz -128 dBc/Hz -129 dBc/Hz -130 dBc/Hz	1 kHz 10 kHz 20 kHz 30 kHz 100 kHz 1 MHz 5 MHz 7 MHz
<i>Typical</i>	Noise sideband	Offset
Frequency = 1000 MHz	-102 dBc/Hz -108 dBc/Hz -108 dBc/Hz -108 dBc/Hz -115 dBc/Hz -133 dBc/Hz -135 dBc/Hz -136 dBc/Hz	1 kHz 10 kHz 20 kHz 30 kHz 100 kHz 1 MHz 5 MHz 7 MHz

Table 1-3: Noise sideband (Cont.)

Characteristics	Description	
Frequency = 2000 MHz	-98 dBc/Hz -107 dBc/Hz -108 dBc/Hz -108 dBc/Hz -115 dBc/Hz -133 dBc/Hz -135 dBc/Hz -135 dBc/Hz	1 kHz 10 kHz 20 kHz 30 kHz 100 kHz 1 MHz 5 MHz 7 MHz
Frequency = 6000 MHz (RSA2208A only)	-90 dBc/Hz -106 dBc/Hz -106 dBc/Hz -108 dBc/Hz -114 dBc/Hz -131 dBc/Hz -132 dBc/Hz -133 dBc/Hz	1 kHz 10 kHz 20 kHz 30 kHz 100 kHz 1 MHz 5 MHz 7 MHz

Table 1-4: Input

Characteristics	Description
Signal input	
Input connector	N type
Input impedance	50 Ω
VSWR	<1.4 (2.5 GHz, RF attenuation≥10 dB) <1.8 (7.5 GHz, RF attenuation≥10 dB, RSA2208A only)
<i>Typical</i>	<1.4 (300 kHz to 10 MHz, RF attenuation≥10 dB) <1.3 (10 MHz to 3 GHz, RF attenuation≥10 dB) <1.4 (3 GHz to 8 GHz, RF attenuation≥10 dB, RSA2208A only)
Maximum input level	
Maximum DC voltage	RF/RF1 to 3: ±0.2 V; Baseband: ±5 V (Option 05)
Maximum input power	+30 dBm (RF attenuation≥10 dB)
Input attenuator	
RF attenuator	0 to 50 dB in 10 dB steps

Table 1-5: Amplitude

Characteristics	Description
Reference level	
Setting range	-51 to +30 dBm in 1 dB steps (RF/RF1) -50 to +30 dBm in 1 dB steps (RF2/RF3, RSA2208A only) -30 to +20 dBm in 2 dB steps (Baseband (Option 05))
Accuracy (-10 to -50 dBm)	±0.2 dB (at 50 MHz, 10 dB attenuation, 20 to 30 °C)
Frequency response (RF attenuation ≥10 dB)	
✓ at 20 to 30 °C	±1.2 dB (RF/RF1) ±1.7 dB (RF2, RSA2208A only) ±1.7 dB (RF3, RSA2208A only) ±0.5 dB (Baseband (Option 05))
<i>Typical</i>	±0.5 dB (10 MHz to 3 GHz) ±0.5 dB (10 MHz to 3.5 GHz, RSA2208A only) ±1.0 dB (3.5 GHz to 6.5 GHz, RSA2208A only) ±1.0 dB (5 GHz to 8 GHz, RSA2208A only) ±0.3 dB (100 kHz to 20 MHz, Option 05 only)
at 10 to 40 °C	±1.5 dB (RF/RF1) ±2.0 dB (RF2, RSA2208A only) ±2.0 dB (RF3, RSA2208A only) ±0.7 dB (Baseband (Option 05))
✓ Absolute amplitude accuracy at calibration point (0 dB attenuation, 20 to 30 °C)	±0.5 dB (at 50 MHz, -20 dBm signal) ±0.3 dB (at 10 MHz in baseband (Option 05), -10 dBm signal)
Input attenuator setting uncertainty	±0.5 dB (at 50 MHz)
Level linearity in display range	±0.2 dB (0 to -40 dBfs) ±0.2 dB (0 to -50 dBfs) ±0.12 dB (0 to -50 dBfs, <i>Typical</i>)

Table 1-6: Dynamic range

Characteristics	Description
1 dB compression input	0 dBm (RF attenuation = 0 dB, 2 GHz)
Second harmonic distortion (-30 dBm tone at input mixer)	-56 dBc (10 MHz to 1500 MHz) -56 dBc (10 MHz to 1750 MHz, RSA2208A only)
✓ 3rd order intermodulation distortion (Reference level = +5 dBm , RF attenuation = 20 dB, Total signal power = -7 dBm)	
Center frequency = 2 GHz	-73 dBc
At 100 MHz to 3 GHz	-73 dBc
At 3 GHz to 8 GHz (RSA2208A only)	-72 dBc

Table 1-6: Dynamic range (Cont.)

Characteristics	Description
✓ Displayed average noise level	-144 dBm/Hz (100 Hz to 10 kHz, Option 05 only) -150 dBm/Hz (10 kHz to 10 MHz, Option 05 only) -148 dBm/Hz (10 MHz to 100 MHz) -148 dBm/Hz (100 MHz to 1 GHz) -148 dBm/Hz (1 GHz to 2 GHz) -147 dBm/Hz (2 GHz to 3 GHz) -142 dBm/Hz (3 GHz to 5 GHz, RSA2208A only) -142 dBm/Hz (5 GHz to 8 GHz, RSA2208A only)
ACLR (W-CDMA downlink, test model 1, 16 ch)	58 dB (5 MHz offset)
Local feed-through to input connector (Typical)	-40 dBm (local frequency 4.2 to 5 GHz) -55 dBm (local frequency 5 to 6 GHz) -60 dBm (local frequency 6 to 7 GHz) -60 dBm (local frequency 7 to 7.7 GHz, RSA2208A only)

Table 1-7: Spurious response

Characteristics	Description
Image Suppression (Typical)	
1 st IF	75 dB (RF/RF1) 70 dB (RF2/RF3, RSA2208A only)
2 nd and 3 rd IF	80 dB (RF/RF1) 75 dB (RF2/RF3, RSA2208A only)
✓ Residual response (Reference level = -30 dBm, RBW = 100 kHz)	
RF, 0.5 to 3 GHz (RSA2203A)	-90 dBm (Span = 2.5 GHz)
RF1, 0.5 to 3.5 GHz (RSA2208A)	-90 dBm (Span = 3 GHz)
RF2, 3.5 to 6.5 GHz (RSA2208A)	-85 dBm (Span = 3 GHz)
RF3, 5 to 8 GHz (RSA2208A)	-85 dBm (Span = 3 GHz)
Baseband (Option 05), 1 to 20 MHz	-93 dBm (Span = 20 MHz)
✓ Spurious response with signal (Span = 10 MHz, Reference level = 0 dBm, RBW = 50 kHz)	
RF/RF1, 2 GHz	-70 dBc (Signal frequency = 2 GHz, Signal level = -5 dBm)
RF2, 5 GHz (RSA2208A)	-70 dBc (Signal frequency = 5 GHz, Signal level = -5 dBm)
RF3, 7 GHz (RSA2208A)	-70 dBc (Signal frequency = 7 GHz, Signal level = -5 dBm)
Baseband (Option 05), 10 MHz	-70 dBc (Signal frequency = 10 MHz, Signal level = -5 dBm)

Table 1-8: Acquisition

Characteristics	Description
Acquisition mode	Single and Continuous
Acquisition memory size	2 MB
Number of data samples in one frame	1024 (Vector mode)
Block size	1 to 500 frames
A/D converter	14 bits, 51.2 Msps
Vector span	10 MHz
Real-time capture bandwidth	RF: 10 MHz; Baseband: 20 MHz (Option 05)

Table 1-9: Sampling rate

Characteristics	Description
Sampling rate (Real Time S/A, Demod, and Time modes)	
10 MHz span	12.8 Msps
5 MHz span	6.4 Msps
2 MHz span	3.2 Msps
1 MHz span	1.6 Msps
500 kHz span	800 ksps
200 kHz span	320 ksps
100 kHz span	160 ksps
50 kHz span	80 ksps
20 kHz span	32 ksps
10 kHz span	16 ksps
5 kHz span	8 ksps
2 kHz span	3.2 ksps
1 kHz span	1.6 ksps
500 Hz span	800 sps
200 Hz span	320 sps
100 Hz span	160 sps

Table 1-10: Frame time

Characteristics	Description
Frame time (Real Time S/A, Demod, and Time modes)	
20 MHz span (Baseband, Option 05)	40 μ s
10 MHz span	80 μ s
5 MHz span	160 μ s
2 MHz span	320 μ s
1 MHz span	640 μ s
500 kHz span	1.28 ms
200 kHz span	3.2 ms
100 kHz span	6.4 ms
50 kHz span	12.8 ms
20 kHz span	32 ms
10 kHz span	64 ms
5 kHz span	128 ms
2 kHz span	320 ms
1 kHz span	640 ms
500 Hz span	1.28 s
200 Hz span	3.2 s
100 Hz span	6.4 s

Table 1-11: RBW (Resolution Bandwidth)

Characteristics	Description
Filter shape	Gaussian, Rectangle, Root Nyquist
Setting range	1 Hz to 10 MHz
Minimum Resolution Bandwidth (S/A mode)	
>2 GHz span	100 kHz
1 to 1.99 GHz span	50 kHz
500 to 990 MHz span	20 kHz
200 to 490 MHz span	10 kHz
100 to 190 MHz span	10 kHz
50 to 90 MHz span	10 kHz
20 to 40 MHz span	10 kHz
10 MHz span	1 kHz
5 MHz span	1 kHz
2 MHz span	1 kHz
1 MHz span	1 kHz
500 kHz span	500 Hz
200 kHz span	200 Hz
100 kHz span	100 Hz
50 kHz span	50 Hz
20 kHz span	20 Hz
10 kHz span	10 Hz
5 kHz span	5 Hz
2 kHz span	2 Hz
1 kHz span	1 Hz
500 Hz span	1 Hz
200 Hz span	1 Hz
100 Hz span	1 Hz

Table 1-12: Analog demodulation

Characteristics	Description
<i>Accuracy (Typical)</i>	
AM demodulation	$\pm 2\%$ (-10 dBfs input at center, 10 to 60% modulation depth)
PM demodulation	$\pm 3^\circ$ (-10 dBfs input at center)
FM demodulation	$\pm 1\%$ of span (-10 dBfs input at center)

Table 1-13: Trigger

Characteristics	Description
Trigger mode	Free run (Triggered by acquisition), Triggered (Triggered by event)
Trigger event source	IF (Level comparator), External (TTL)
Internal trigger comparator data source	A/D converter output
Pre/Post trigger setting	Trigger position settable from 0 to 100% of total data length.
IF level trigger setting range	1 to 100% (100% is full-scale of A/D converter output)
External trigger input	
Input voltage	High: +1.6 to +5 V; Low: 0 to +0.5 V
Input impedance	>2 k Ω
Trigger output voltage	High: >2.0 V, Low: <0.4 V (output current <1 mA)
Trigger marker position timing uncertainty	± 2 sample points

Table 1-14: Measurement function

Characteristics	Description
S/A mode	Noise power, Channel power, Adjacent channel power ratio, Occupied bandwidth, Emission bandwidth, Carrier to Noise ratio, Carrier frequency, Spurious
Demod and Time modes	I/Q vs. Time, Power vs. Time, Frequency vs. Time, CCDF, Analog demodulation (AM, FM, PM)

Table 1-15: Display

Characteristics	Description
View	
Number of views	1, 2, 3, or 4
Number of display traces	2
LCD	
Panel size	213 mm (8.4 in)
Resolution	800 × 600 pixels
Color	Maximum 256 colors

Table 1-16: Marker, trace, and display line

Characteristics	Description
Marker type	Normal, Reference, and Band power
Search function	Peak right, Peak left, Maximum, Larger peak, and Smaller peak
Trace content	Active, Average, Max hold, Min hold, View, and Off
Display line	Horizontal line 1 and 2, Vertical line 1 and 2

Table 1-17: Controller and interface

Characteristics	Description
Controller	
CPU	Intel Pentium III 850 MHz
DRAM	256 Mbyte DIMM
OS	Windows 98
System bus	PCI, ISA
Storage medium	
Hard disk	10 Gbyte 2.5 inch IDE
Floppy disk	1.44 Mbyte 3.5 inch
Interface	
GPIB	IEEE 488.1
LAN	10/100 BASE-T (IEEE 802.3)
Printer port	USB
Mouse	USB
Keyboard	USB
Monitor out	VGA (D-SUB 15 pins)

Table 1-18: Power requirements

Characteristics	Description
Rating voltage	100 to 240 VAC
Voltage range	90 to 250 VAC
Line frequency	47 to 63 Hz
Mains Fuse Data	Densei-Lambda supplies: 5 A, Time-delayed, 250 V (not operator replaceable) Cosel supply: 2 A, Time-delayed, 250 V (not operator replaceable)
Heat dissipation	
Maximum power	350 VA
Maximum line current	5 A rms at 50 Hz (90 V line with 5% clipping)
Surge current	Maximum 52 A peak (25 °C) for ≤5 line cycles after the product has been turned off for at least 30 s.

Table 1-19: Power connector

Characteristics	Description
Preamp power connector	
Connector type	LEMO 6 poles
Pin assignment	Pin 1: NC, Pin 2: ID1, Pin 3: ID2, Pin 4: -12 V, Pin 5: GND, Pin 6: +12 V

Physical Characteristics

Table 1-20: Physical characteristics

Characteristics	Description
Dimensions	
Width	425 mm (16.7 in) without belts
Height	215 mm (8.5 in) without feet
Depth	425 mm (16.7 in) without cover and feet
Net weight	19 kg

Environmental Characteristics

Table 1-21: Environmental characteristics

Characteristics	Description
Temperature	
Operating	+10 to +40 °C
Nonoperating	-20 to +60 °C
Relative humidity	
Operating and nonoperating	20 to 80% (no condensation), maximum wet-bulb temperature 29 °C
Altitude	
Operating	Up to 3000 m (10000 ft)
Nonoperating	Up to 12000 m (40000 ft)
Vibration	
Operating	2.65 m/s ² rms (0.27 G rms), 5 to 500 Hz
Nonoperating	22.3 m/s ² rms (2.28 G rms), 5 to 500 Hz
Shock	
Nonoperating	196 m/s ² (20 G), half-sine, 11 ms duration Three shocks in each direction along each major axis, total of 18 shocks
Cooling clearance	
Bottom	20 mm (0.79 in)
Both sides	50 mm (1.97 in)
Rear	50 mm (1.97 in)

Table 1-22: Certifications and compliances

Characteristic	Description																		
EC Declaration of Conformity – EMC	<p>Meets intent of Directive 89/336/EEC for Electromagnetic Compatibility. Compliance was demonstrated to the following specifications as listed in the Official Journal of the European Communities:</p> <table border="0"> <tr> <td>EN 61326</td> <td>EMC requirements for Class A electrical equipment for measurement, control and laboratory use. ¹</td> </tr> <tr> <td>IEC 61000-4-2</td> <td>Electrostatic discharge immunity (Performance criterion B)</td> </tr> <tr> <td>IEC 61000-4-3</td> <td>RF electromagnetic field immunity (Performance criterion A)</td> </tr> <tr> <td>IEC 61000-4-4</td> <td>Electrical fast transient / burst immunity (Performance criterion B)</td> </tr> <tr> <td>IEC 61000-4-5</td> <td>Power line surge immunity (Performance criterion B)</td> </tr> <tr> <td>IEC 61000-4-6</td> <td>Conducted RF immunity (Performance criterion A)</td> </tr> <tr> <td>IEC 61000-4-11</td> <td>Voltage dips and interruptions immunity (Performance criterion B)</td> </tr> <tr> <td>EN 61000-3-2</td> <td>AC power line harmonic emissions</td> </tr> <tr> <td>EN 61000-3-3</td> <td>Power line voltage fluctuation/flicker</td> </tr> </table>	EN 61326	EMC requirements for Class A electrical equipment for measurement, control and laboratory use. ¹	IEC 61000-4-2	Electrostatic discharge immunity (Performance criterion B)	IEC 61000-4-3	RF electromagnetic field immunity (Performance criterion A)	IEC 61000-4-4	Electrical fast transient / burst immunity (Performance criterion B)	IEC 61000-4-5	Power line surge immunity (Performance criterion B)	IEC 61000-4-6	Conducted RF immunity (Performance criterion A)	IEC 61000-4-11	Voltage dips and interruptions immunity (Performance criterion B)	EN 61000-3-2	AC power line harmonic emissions	EN 61000-3-3	Power line voltage fluctuation/flicker
EN 61326	EMC requirements for Class A electrical equipment for measurement, control and laboratory use. ¹																		
IEC 61000-4-2	Electrostatic discharge immunity (Performance criterion B)																		
IEC 61000-4-3	RF electromagnetic field immunity (Performance criterion A)																		
IEC 61000-4-4	Electrical fast transient / burst immunity (Performance criterion B)																		
IEC 61000-4-5	Power line surge immunity (Performance criterion B)																		
IEC 61000-4-6	Conducted RF immunity (Performance criterion A)																		
IEC 61000-4-11	Voltage dips and interruptions immunity (Performance criterion B)																		
EN 61000-3-2	AC power line harmonic emissions																		
EN 61000-3-3	Power line voltage fluctuation/flicker																		
Australia/New Zealand Declaration of Conformity – EMC	<p>Complies with EMC provision of Radiocommunications Act per the following standard(s):</p> <table border="0"> <tr> <td>AS/NZS 2064.1/2</td> <td>Industrial, Scientific, and Medical Equipment: 1992</td> </tr> </table> <p>To ensure compliance with EMC requirements, only high quality shielded cables having a reliable, continuous outer shield (braid & foil) with full coverage, low impedance connections to shielded connector housings at both ends should be connected to this product..</p>	AS/NZS 2064.1/2	Industrial, Scientific, and Medical Equipment: 1992																
AS/NZS 2064.1/2	Industrial, Scientific, and Medical Equipment: 1992																		
EC Declaration of Conformity – Low Voltage	<p>Compliance was demonstrated to the following specification as listed in the Official Journal of the European Union:</p> <p>Low Voltage Directive 73/23/EEC, amended by 93/68/EEC</p> <table border="0"> <tr> <td>EN 61010-1:2001</td> <td>Safety requirements for electrical equipment for measurement control and laboratory use.</td> </tr> </table>	EN 61010-1:2001	Safety requirements for electrical equipment for measurement control and laboratory use.																
EN 61010-1:2001	Safety requirements for electrical equipment for measurement control and laboratory use.																		
U.S. Nationally Recognized Testing Laboratory Listing	<table border="0"> <tr> <td>UL61010B-1</td> <td>Standard for electrical measuring and test equipment.</td> </tr> </table>	UL61010B-1	Standard for electrical measuring and test equipment.																
UL61010B-1	Standard for electrical measuring and test equipment.																		
Canadian Certification	<table border="0"> <tr> <td>CAN/CSA C22.2 No. 1010.1</td> <td>CSA safety requirements for electrical and electronic measuring and test equipment.</td> </tr> </table>	CAN/CSA C22.2 No. 1010.1	CSA safety requirements for electrical and electronic measuring and test equipment.																
CAN/CSA C22.2 No. 1010.1	CSA safety requirements for electrical and electronic measuring and test equipment.																		
Additional Compliance	<table border="0"> <tr> <td>ANSI/ISA S82.02.01:1999</td> <td>Safety standard for electrical and electronic test, measuring, controlling, and related equipment.</td> </tr> <tr> <td>IEC61010-1</td> <td>Safety requirements for electrical equipment for measurement, control, and laboratory use.</td> </tr> </table>	ANSI/ISA S82.02.01:1999	Safety standard for electrical and electronic test, measuring, controlling, and related equipment.	IEC61010-1	Safety requirements for electrical equipment for measurement, control, and laboratory use.														
ANSI/ISA S82.02.01:1999	Safety standard for electrical and electronic test, measuring, controlling, and related equipment.																		
IEC61010-1	Safety requirements for electrical equipment for measurement, control, and laboratory use.																		

¹ Emissions which exceed the levels required by this standard may occur when this equipment is connected to a test object.

Table 1–22: Certifications and compliances (Cont.)

Characteristic	Description
Installation (Overvoltage) Category	<p>Terminals on this product may have different installation (overvoltage) category designations. The installation categories are:</p> <p>CAT III Distribution-level mains (usually permanently connected). Equipment at this level is typically in a fixed industrial location.</p> <p>CAT II Local-level mains (wall sockets). Equipment at this level includes appliances, portable tools, and similar products. Equipment is usually cord-connected.</p> <p>CAT I Secondary (signal level) or battery operated circuits of electronic equipment.</p>
Pollution Degree Descriptions	<p>A measure of the contaminants that could occur in the environment around and within a product. Typically the internal environment inside a product is considered to be the same as the external. Products should be used only in the environment for which they are rated.</p> <p>Pollution Degree 1 No pollution or only dry, nonconductive pollution occurs. Products in this category are generally encapsulated, hermetically sealed, or located in clean rooms.</p> <p>Pollution Degree 2 Normally only dry, nonconductive pollution occurs. Occasionally a temporary conductivity that is caused by condensation must be expected. This location is a typical office/home environment. Temporary condensation occurs only when the product is out of service.</p> <p>Pollution Degree 3 Conductive pollution, or dry, nonconductive pollution that becomes conductive due to condensation. These are sheltered locations where neither temperature nor humidity is controlled. The area is protected from direct sunshine, rain, or direct wind.</p> <p>Pollution Degree 4 Pollution that generates persistent conductivity through conductive dust, rain, or snow. Typical outdoor locations.</p>
Safety Certification Compliance	
Equipment Type	Test and measuring
Safety Class	Class 1 (as defined in IEC61010-1, Annex H) – grounded product
Operating Temperature Range	+5 to +40 °C
Overvoltage Category	Overvoltage Category II (as defined in IEC61010-1, Annex J)
Pollution Degree	Pollution Degree 2 (as defined in IEC61010-1). Note: Rated for indoor use only.

Operating Information

Installation

Supplying Operating Power



WARNING. AC POWER SOURCE AND CONNECTION. *The analyzer operates from a single-phase power source. It has a three-wire power cord and two-pole, three-terminal grounding type plug. The voltage to ground (earth) from either pole of the power source must not exceed the maximum rated operating voltage, 250 volts.*

Before making connection to the power source, be sure the analyzer has a suitable two-pole, three-terminal grounding-type plug.

GROUNDING. *This instrument is safety Class 1 equipment (IEC designation). All accessible conductive parts are directly connected through the grounding conductor of the power cord to the grounded (earthing) contact of the power plug.*



WARNING. *The power input plug must be inserted only in a mating receptacle with a grounding contact where earth ground has been verified by a qualified service person. Do not defeat the grounding connection. Any interruption of the grounding connection can create an electric shock hazard.*

For electric shock protection, the grounding connection must be made before making connection to the instrument's input or output terminals.

Power Cord Information

A power cord with the appropriate plug configuration is supplied with each analyzer. Table 2-1 gives the color-coding of the conductors in the power cord. If you require a power cord other than the one supplied, refer to Table 2-2, Power Cord Identification.

Table 2-1: Power-cord conductor identification

Conductor	Color	Alternate color
Ungrounded (Line)	Brown	Black
Grounded (Neutral)	Light Blue	White
Grounded (Earthing)	Green/Yellow	Green

Table 2-2: Power cord identification

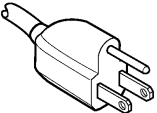
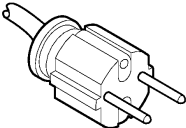
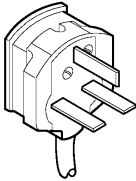
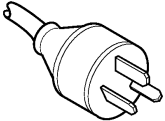
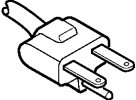
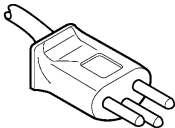
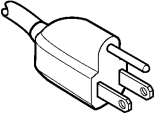
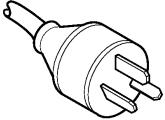
Plug configuration	Normal usage	Option number
	North America 120 V	A0
	Universal Euro 230 V	A1
	United Kingdom 230 V	A2
	Australia 240 V	A3
	North America 240 V	A4
	Switzerland 220 V	A5
	Japan 100 V	A6
	China 240 V	A10
	No power cord supplied.	A99

Operating Voltage

This analyzer operates with any line voltage from 90–250 VAC_{RMS} with any line frequency from 47–63 Hz. Before plugging the cord in the outlet, be sure that the power supply voltage is proper.

Operating Environment

The following environmental requirements are provided to ensure proper operation and long instrument life.

Operating Temperature

Operate the analyzer where the ambient air temperature is from +10 °C to +40 °C with no diskette in the floppy drive. Store the analyzer in ambient temperatures from -20 °C to +60 °C with no diskette in the floppy drive. After storage at temperatures outside the operating limits, allow the chassis to stabilize at a safe operating temperature before applying power.

Ventilation Requirements

The analyzer is cooled by air drawn by external fans on the side panel. To ensure proper cooling of the analyzer, allow at least 5 cm clearance on both sides of and behind the analyzer. The feet on the bottom of the analyzer provide the required clearance when set on flat surfaces. The top of the analyzer does not require ventilation clearance.

Applying Power

Power on the analyzer using the following procedure:

AC Power Requirements

The analyzer operates from an AC line frequency of 47–63 Hz, over the range of 90–250 Volts, without the need for configuration, except the power cord. Refer to page 2–2 for the power cord options.

The maximum power consumption is 350 W. Refer to *Specifications* for additional information on power and environmental requirements.



CAUTION. Use only power cords that are approved for the country of use. Using non-approved power cords could result in fire or shock hazard.

Connecting the Power Cord

Plug the power cord into the AC input on the rear panel.

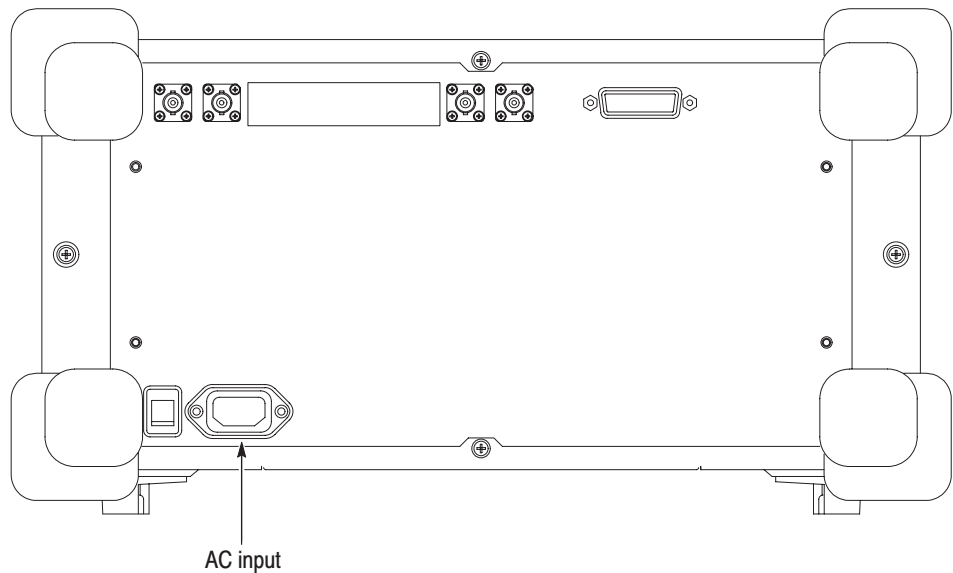
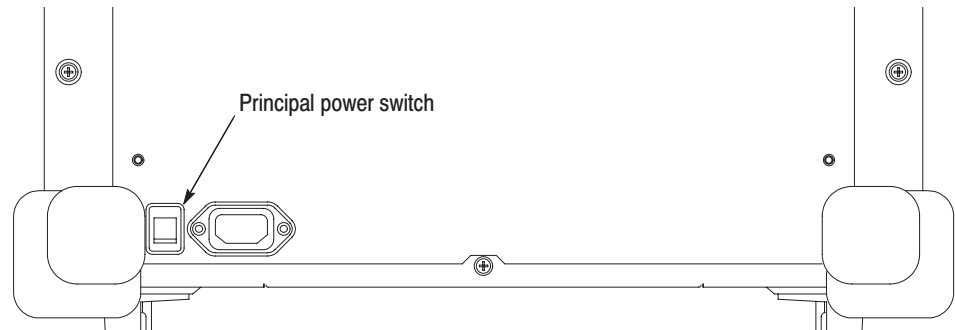

Figure 2-1: AC Input (rear panel)

Turning on the Analyzer

1. Turn on the principal power switch on the rear panel.

**Figure 2-2: Principal power switch (rear panel)**

When you turn on the principal power switch, a voltage is applied to the analyzer standby circuit. Make sure the LED next to the power switch on the front panel lights up in orange.

2. Turn on the power switch (**ON/STANDBY**) on the lower left of the front panel. The LED next to the power switch changes to green.

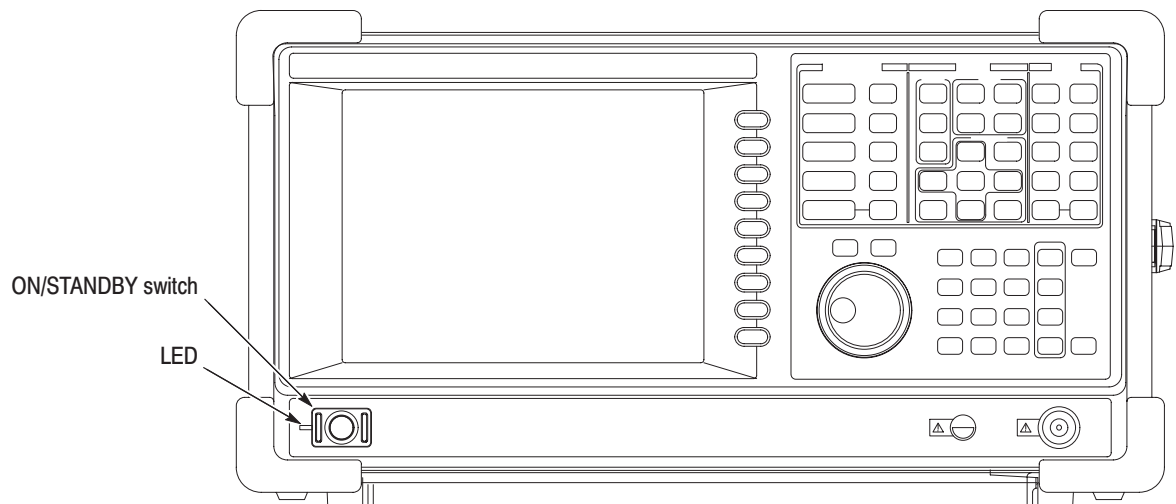
**Figure 2-3: Front panel power switch (ON/STANDBY switch)**

When you turn on the analyzer, Windows 98 boots up. After several minutes, the analyzer application starts up.

The initial screen appears as shown in Figure 2-4. The displayed spectrum represents the noise floor of the analyzer.

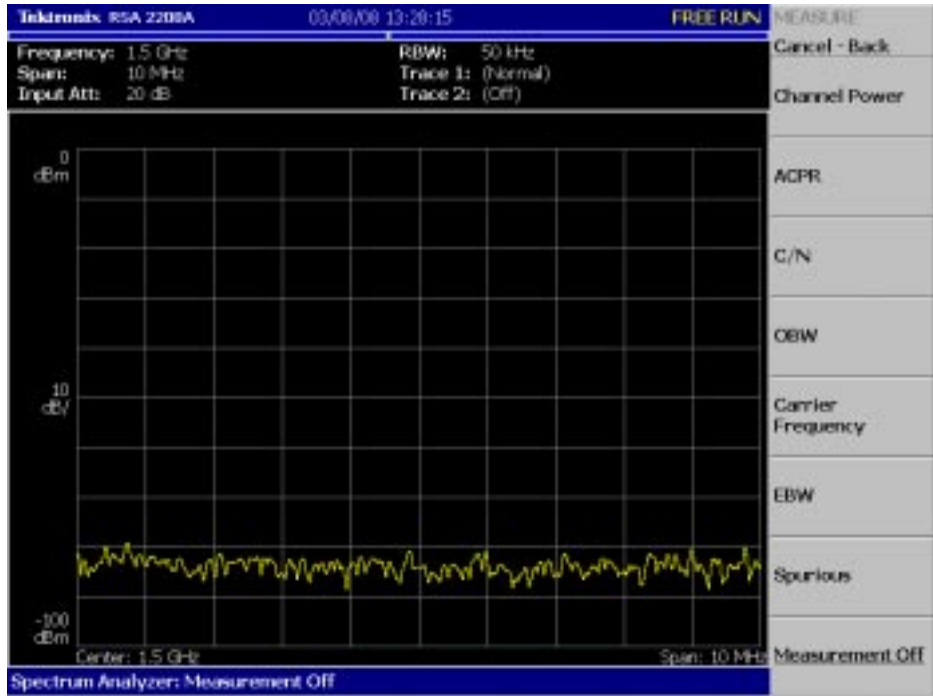

Figure 2-4: Initial screen

If “UNCAL” is displayed on top of the screen, run the gain calibration routine (refer to *Gain Calibration* on page 5–9).



CAUTION. Never apply signals with a combined amplitude greater than +30 dBm to the RF INPUT connector. If you exceed this input rating, you can permanently damage the analyzer. (The RF INPUT connector is shown in Figure 2-5.)

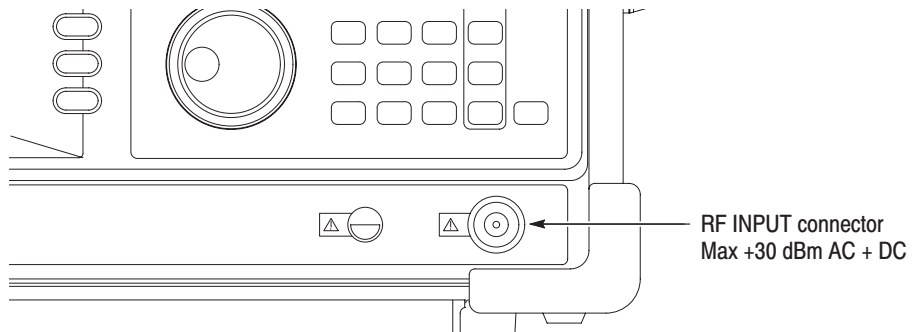

Figure 2-5: RF INPUT connector

Setting Up the Stand

To set up the stand, place the analyzer on a table. Lift the front of the analyzer and pull out the stand until it is perpendicular to the analyzer.

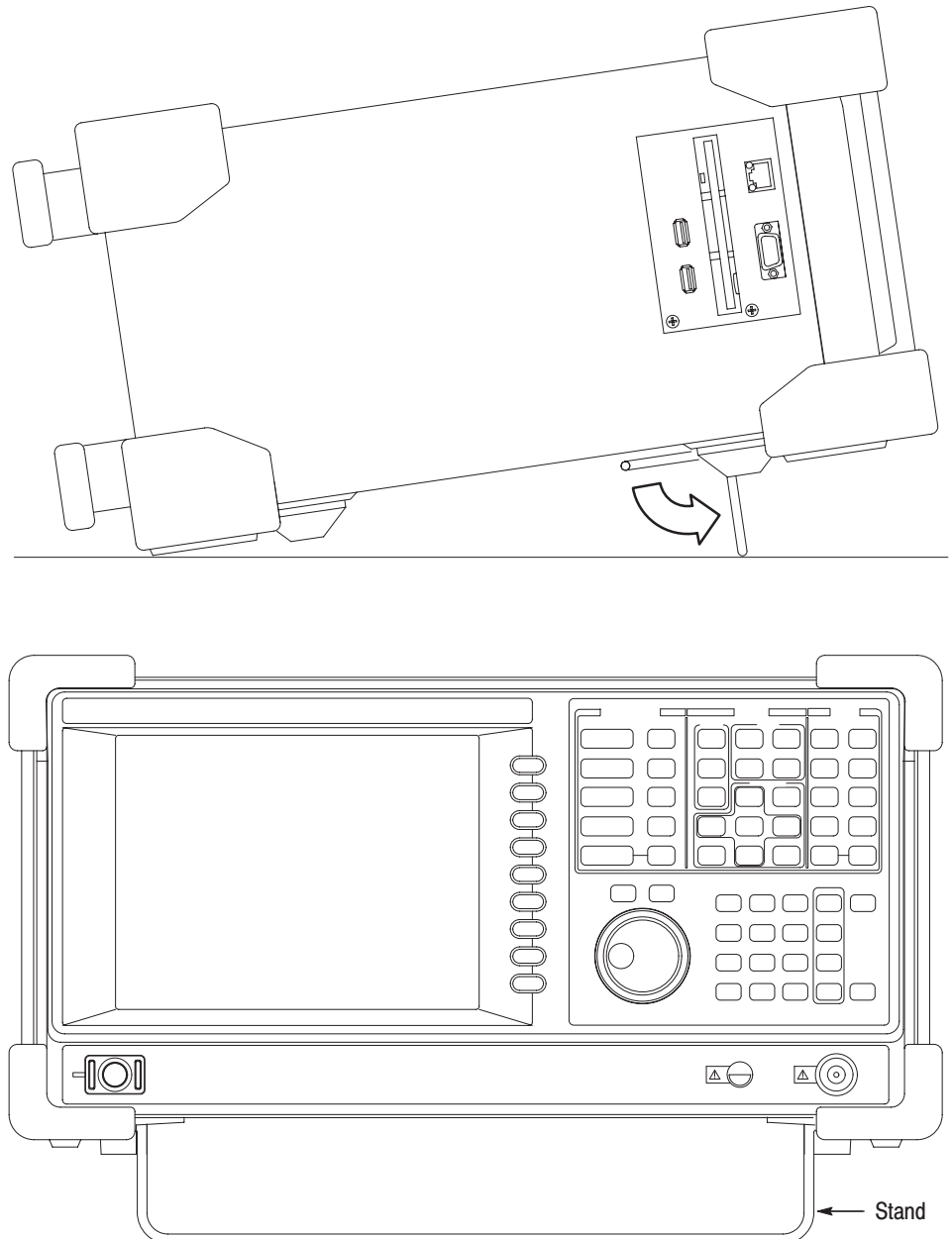

Figure 2-6: Setting up the stand

Powering Off the Analyzer

Turn off the power switch on the front panel.



CAUTION. *When you power on or off the analyzer, you must use the front-panel ON/STANDBY switch. Failure to do so may cause the operating system to shut down improperly.*

When you power on the analyzer again, wait at least 10 seconds after the last power off.

When you press the front-panel ON/STANDBY switch, the analyzer starts a shutdown process (including a Windows shutdown) to preserve settings and then power off. The LED next to the power switch changes to orange. Avoid using the rear-panel power switch or disconnecting the power cord to power off the analyzer.

To completely remove power to the analyzer, perform the shutdown just described, and then set the power switch on the rear panel to off.

NOTE. *Turning off the front-panel ON/STANDBY switch does not shut down the principal power supply completely. When you turn off the principal power supply, use the principal power switch on the rear panel. Turning off the principal power switch turns off the front-panel LED.*

When you do not use the analyzer for a long time or in case of emergency, you should unplug the power cable.

Restart

When the analyzer operates abnormally, use the following procedure to turn off the analyzer and turn it on again.

NOTE. *When the analyzer operates abnormally, it will not be shut down by turning off the front-panel power switch alone.*

1. Make sure that the front-panel power switch is in the off position.
2. Turn off the principal power switch on the rear panel.
3. Wait at least 10 seconds and then turn on the principal power switch again.
4. Turn on the front-panel power switch.

When Scan Disk Appears

If the analyzer was not shut down properly, Windows Scan Disk may run when you turn on the analyzer. When the Scan Disk screen appears, wait until the Scan Disk is completed. If an error is detected, refer to the Windows manual for treatment. For more information on accessing Windows on the analyzer, refer to *Using Windows 98* on page 2–46.

When the Display Brightness Is Not Even

It is a characteristic of the LCD (Liquid Crystal Display) panel to sometimes have uneven brightness, dead pixels (dots that never turn on) or stuck pixels (dots that always stay on). This is neither a malfunction nor a defect, and not a cause for repair or exchange.

Repackaging Instructions

If you ship the analyzer, pack it in the original shipping carton and packing material. If the original packing material is not available, package the instrument as follows:

1. Obtain a corrugated cardboard shipping carton with inside dimensions at least 15 cm (6 in.) taller, wider, and deeper than the instrument. The shipping carton must be constructed of cardboard with 170 kg (375 lb.) test strength.
2. If you are shipping the instrument to a Tektronix field office for repair, attach a tag to the instrument showing the instrument owner and address, the name of the person to contact about the instrument, the instrument type, and the serial number.
3. Wrap the instrument with polyethylene sheeting or equivalent material to protect the finish.
4. Cushion the instrument in the shipping carton by tightly packing dunnage or urethane foam on all sides between the carton and the analyzer. Allow 7.5 cm (3 in.) on all sides, top, and bottom.
5. Seal the shipping carton with shipping tape or an industrial stapler.

NOTE. *Do not ship the instrument with a diskette inside the floppy disk drive. When the diskette is inside the drive, the disk release button sticks out. This makes the button more prone to damage than it would otherwise be.*

Installed Options

Your instrument may be equipped with one or more instrument options. Except for the line-cord options described by Table 2-2 on page 2-2, all options and optional accessories are listed and described in Section 7, *Options*. For further information and prices of instrument options, see your Tektronix Products catalog or contact your Tektronix Field Office.

Operating Instructions

Before performing any service, read the following operating instructions. These instructions are at the level appropriate for servicing the analyzer. The user manual contains more complete operating instructions. This section describes basic procedures, such as applying power, displaying measurement results, and powering off the analyzer, using default settings as far as possible for simplicity. The following procedures are contained in this section:

- Preparations: Connecting devices and applying the power
- Displaying spectrum
- Using markers and peak search
- Using averaging and comparison displays
- Displaying spectrogram
- Spectrum analysis
- Modulation analysis
- Using Windows 98
- Shutting off the power

You must complete the installation procedures (starting on page 2-1) before performing any of the following steps.

Preparations

This tutorial uses a digitally-modulated signal. The following equipment is used as a signal source.

- Analog signal generator (example: HP8657B)
- One 50 Ω coaxial cable

Connecting the Signal Generator

1. Connect the output of the signal generator to the RF INPUT connector on the analyzer front panel using a coaxial cable (see Figure 2-7).

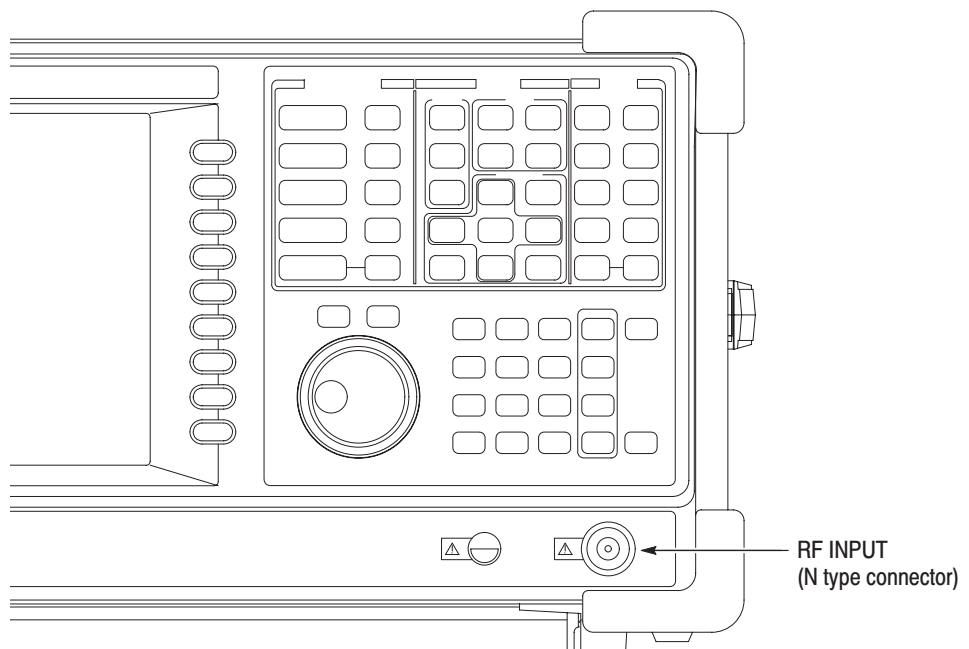

Figure 2-7: Cable connection

2. Set the signal generator as follows:

Center frequency	100 MHz
Output level	-10 dBm
Modulation type	AM
Modulation source	Internal 10 kHz
Modulation depth	50%

Applying the Power

1. Apply power to the signal generator.
2. Turn on the principal power switch (**PRINCIPAL POWER SWITCH**) on the rear panel, as shown in Figure 2–8. The orange LED on the front panel lights.

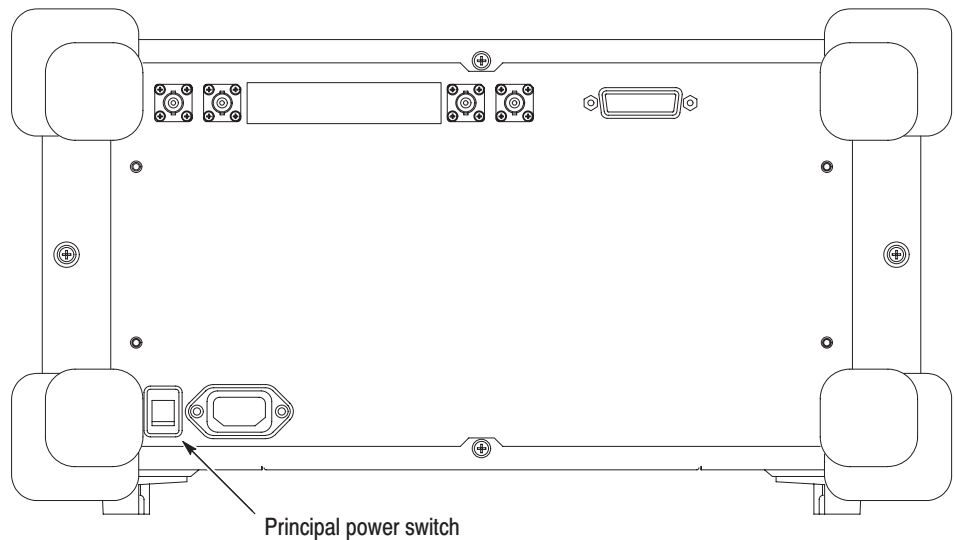

Figure 2–8: Principal power switch (rear panel)

3. Turn on the power switch (**ON/STANDBY**) on the front panel, as shown in Figure 2–9.

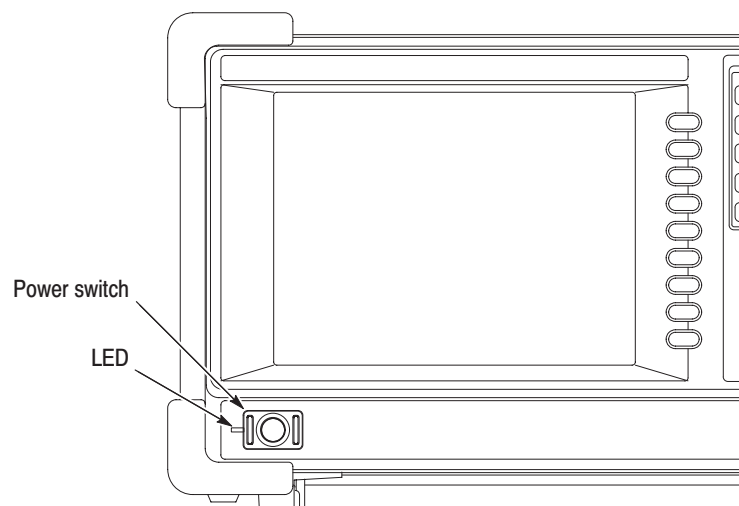

Figure 2–9: Power switch (ON/STANDBY)

The initial screen shown in Figure 2–10 appears after Windows 98 starts up (the background color is in white on this manual to make figures more viewable).

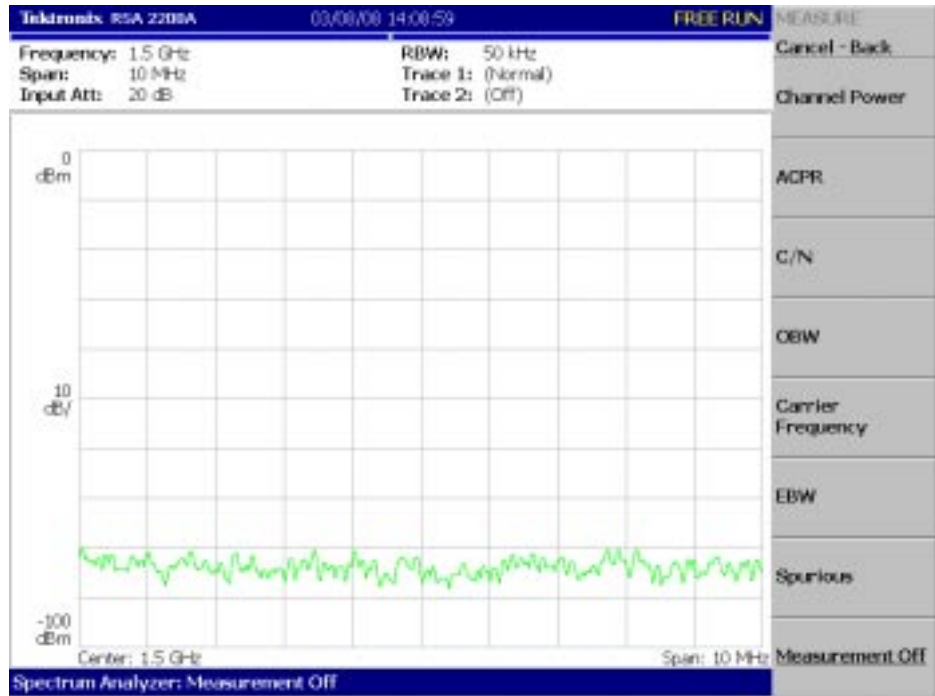

Figure 2–10: Initial screen

Restoring Default Settings

The analyzer saves the settings when it is turned off. When you turn on the analyzer, it starts with the settings as they were when it was shut down.

This tutorial starts with the factory default settings. Perform the following steps to restore the factory default settings:

1. Press the **SYSTEM** key.

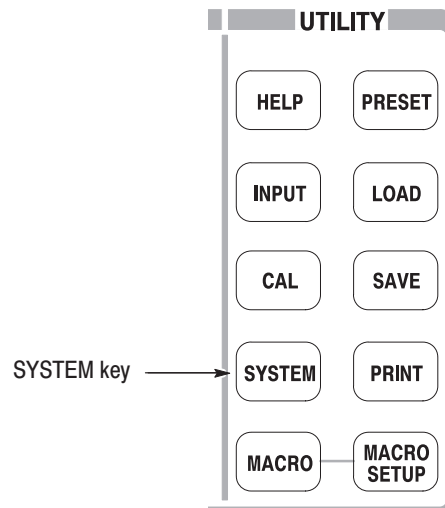

2. Press the **Reset All to Factory Defaults** side key.

The instrument is now ready to take measurements.

Displaying Spectrum

This section describes how to set the frequency, span, and amplitude first, and then appropriately display the spectrum. Figure 2–11 shows the settings.

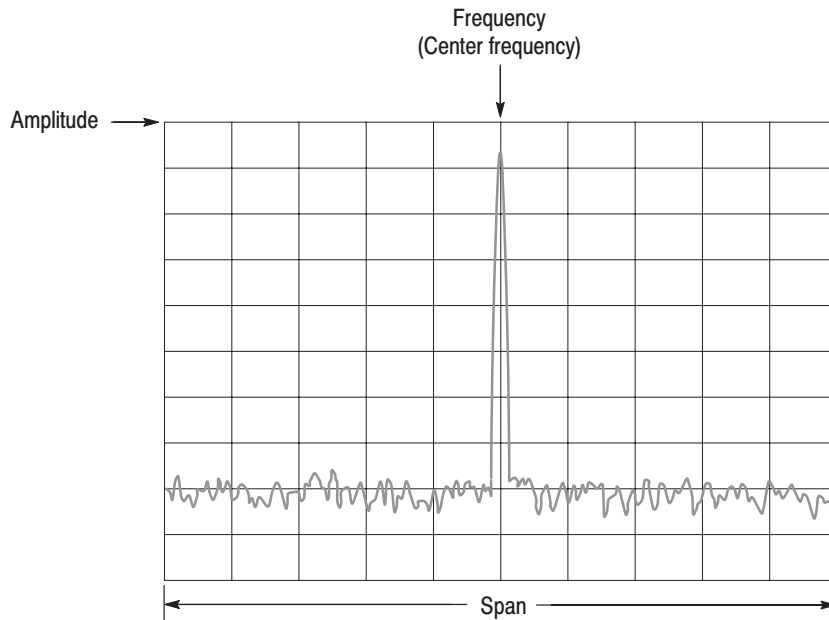
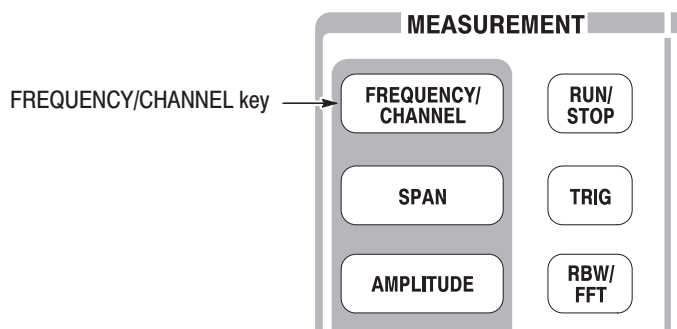

Figure 2–11: Frequency, span, and amplitude settings

Setting Center Frequency and Span

The center frequency is set to 1.5 GHz, and span is set to 10 MHz when you power on the analyzer. Change the settings of center frequency and span to display the waveform around 100 MHz.

1. Press the **FREQUENCY/CHANNEL** key on the front panel.



The FREQUENCY/CHANNEL menu, shown in Figure 2–12, is displayed on the right side of the screen. Notice that the Frequency menu item is available for entering the numeric value for center frequency.

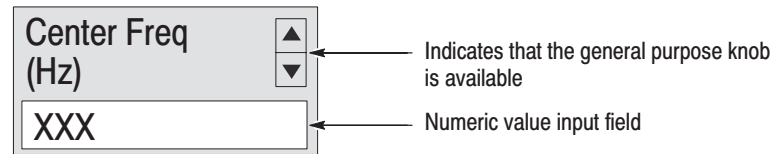

Figure 2–12: Menu items for numeric value input

You can change the value using the general purpose knob or enter the value using the numeric value entry keypad, shown in Figure 2–13.

2. Enter the new center frequency at 100 MHz. As the interval between 1.5 GHz (current setting) and 100 MHz is wide, it is more convenient to use the keypad here.

Press **1 0 0 MHz**, in order, on the keypad.

The **GHz**, **MHz**, **kHz**, and **Hz** keys also function as the enter key. When you press any of these keys, the numeric value you enter will be set immediately.

If you enter incorrect values, clear them using the **BKSP** (back space) key and then enter the correct digit.

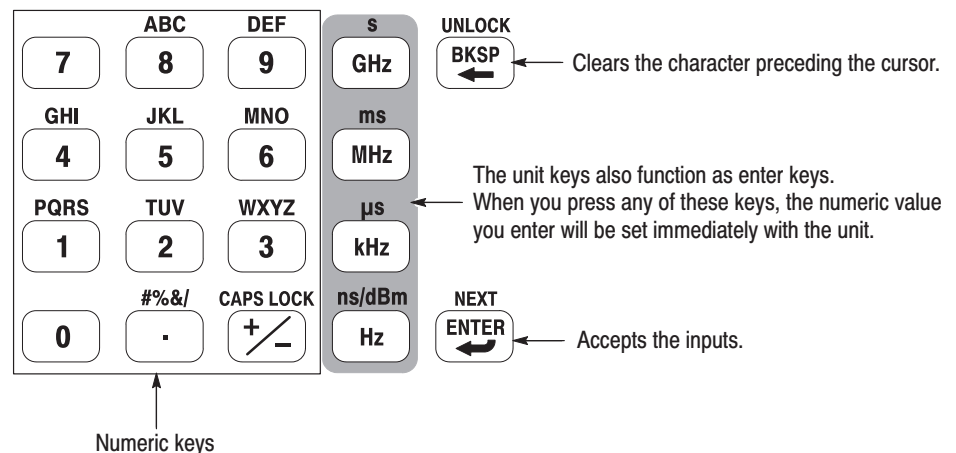

Figure 2–13: Numeric value entry keypad

The spectrum waveform is displayed on the screen as shown in Figure 2–14. The current setting is displayed on the bottom of the screen (“Center Freq (MHz): 100” in this example).

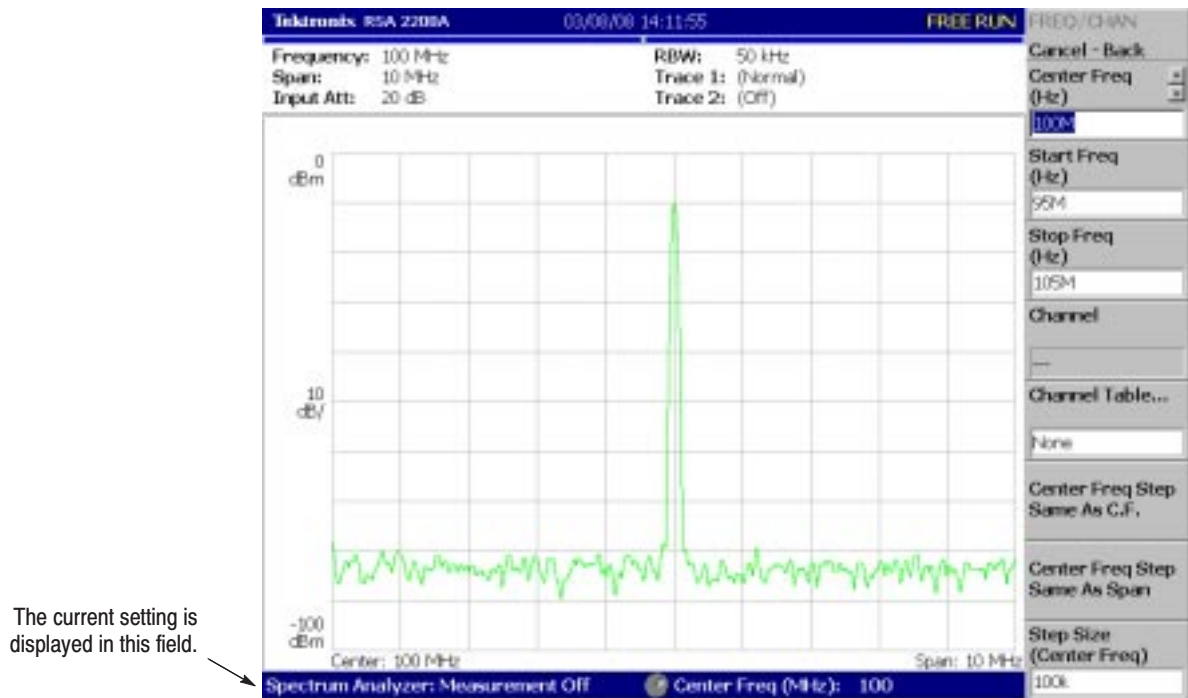
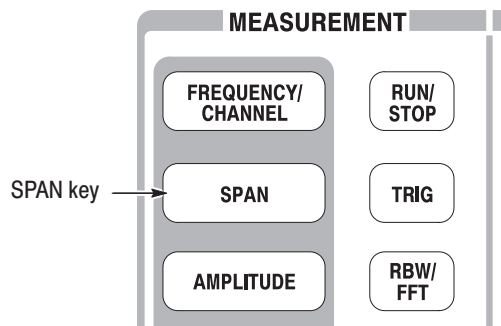

Figure 2-14: Center frequency of 100 MHz, span of 10 MHz

The next step is to set the span. It is currently set to 10 MHz as the default value. Change the setting to 20 kHz.

3. Press the **SPAN** key on the front panel.



The **Span** menu item is selected.

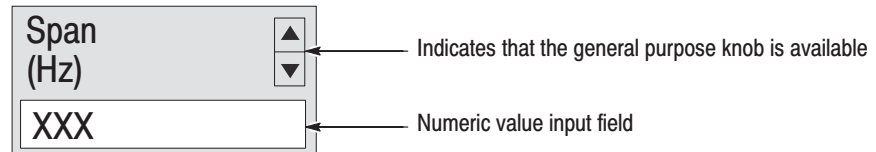

4. Turn the general purpose knob to the left to select **20k**.
The hardware is set with the selected value immediately.

The spectrum waveform is displayed on the screen as shown in Figure 2–15.

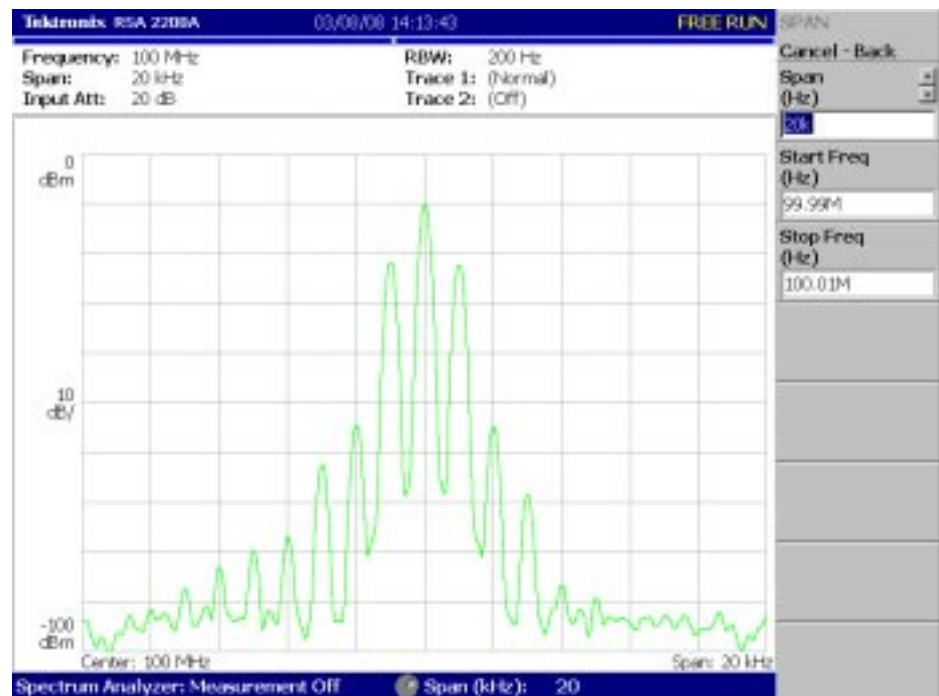

Figure 2–15: Center frequency of 100 MHz, span of 20 kHz

Setting Up Amplitude

In Figure 2–16, the vertical scale shows the spectrum view, set up for 10 dB per division. Ref level is the maximum value of the vertical axis, and it is set to 0 dBm when the analyzer is powered on. Observe the change in the waveform as you change this setting in the following procedure:

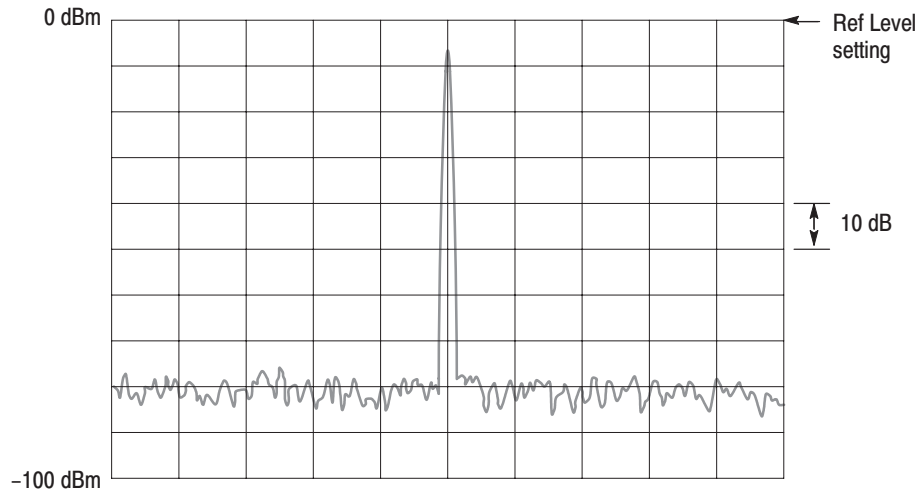
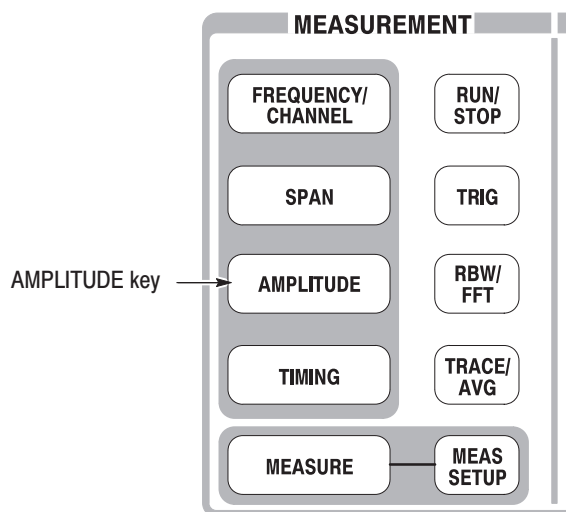

Figure 2-16: Setting amplitude

1. Press the **Amplitude** key on the front panel.



The Amplitude menu is displayed on the right side of the screen. Notice that the Ref Level item is available for entering amplitude (see Figure 2–17).

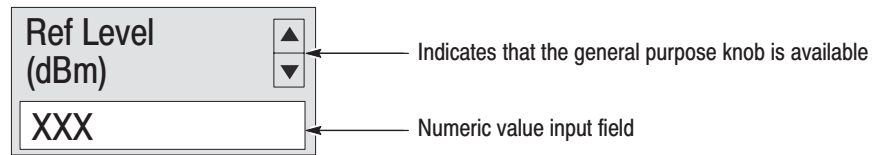

Figure 2-17: Menu items for numeric value input

2. Observe the changes in the waveform as you turn the general purpose knob.
 - As you turn the knob to the right, the amplitude increases and waveform shifts to a relatively lower position.
 - As you turn the knob to the left, the amplitude decreases and waveform shifts to a relatively higher position.

In Figure 2-18, the amplitude is set to 10 dBm. When the amplitude is set to 0 dBm or higher, a blue standard line is displayed indicating 0 dBm.

3. Set the Ref Level back to 0 dBm after confirming the amplitude operation.

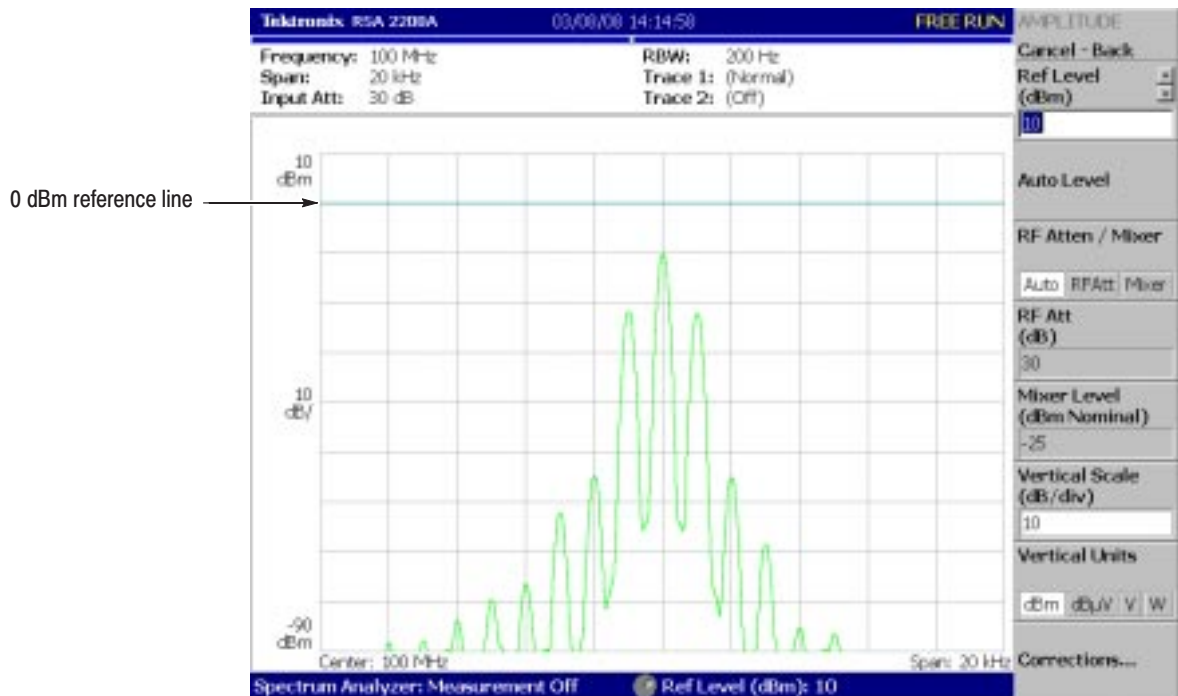
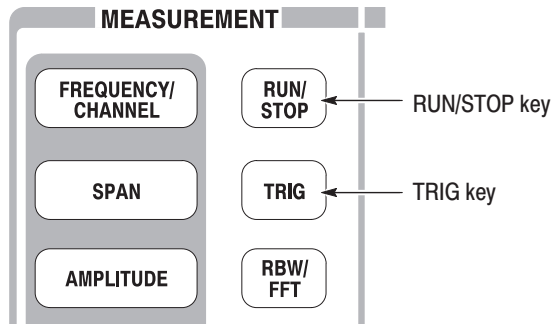

Figure 2-18: Reference level of 10 dBm

Starting and Stopping Data Acquisition

Use the **RUN/STOP** key to start or stop data acquisition. There are two acquisition modes: the continuous mode, in which data is acquired repeatedly and the single mode, in which one waveform is acquired. You can select the mode using the Trig menu.



By default, the analyzer is now acquiring data in the continuous mode.

1. Press the **RUN/STOP** key to stop data acquisition.

When acquisition stops, "PAUSE" is shown in the status indicator on screen (see Figure 2–19).

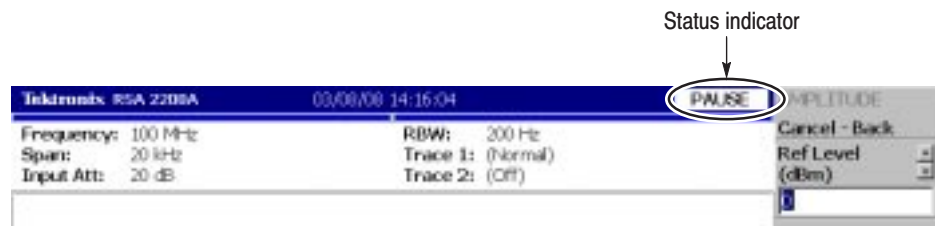

Figure 2–19: Status indicator

2. Acquire data in the single mode using the following steps:
 - a. Press the **TRIG** key on the front panel.
 - b. Press the **Repeat...** side key and select **Single**.
 - c. Press the **RUN/STOP** key to acquire data. One waveform is acquired and displayed every time you press the key.
3. Press the **Repeat...** side key again and select Continuous to return to the continuous mode.

When acquisition starts, "READY" is displayed in the status indicator, indicating that the analyzer is ready for trigger.

Using Markers and Peak Search

The markers are used to measure amplitude or frequency (and also to find the peak signal).

One or two markers can be displayed as Marker 1 and 2. To measure an absolute value, only Marker 1 is used, and that is called “single marker mode.” To measure a relative value, Markers 1 and 2 are used, and that is called “delta marker mode.” To position the markers, use the general purpose knob or the numeric input keypad.

Measuring with a Single Marker

1. Press the **MARKER SETUP** key on the front panel.

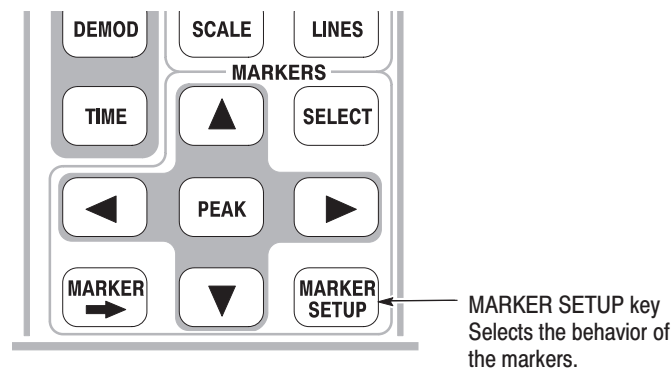

2. Press the **Markers** side key to select **Single**.

The marker (□) appears at center on the waveform.

3. The **Marker X Position** menu item is selected by default. Turn the general purpose knob to move the marker to a measurement point (see Figure 2–20).

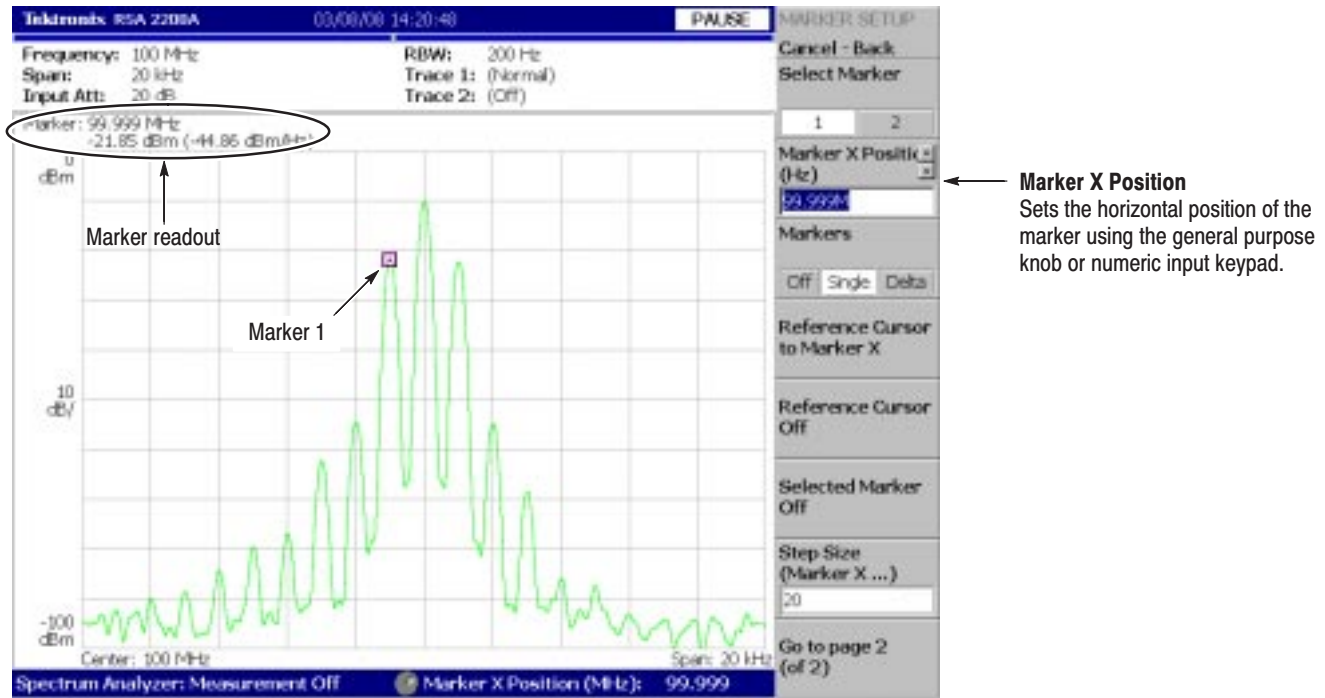

Figure 2–20: Measurement with a single marker

Measuring Difference with Delta Marker

Turn on Marker 1 and 2 to measure the difference in amplitude and frequency. On the screen, the symbol “□” represents the active marker and “◇” represents the fixed marker. You can operate only the active marker.

1. Press the **MARKER SETUP** key on the front panel.
2. Press the **Markers** side key to select **Delta**.
The fixed marker (◇) appears at the active marker position.
3. Make sure that **1** (Marker 1) is selected in the **Select Marker** menu item. This means that Marker 1 is the active marker.
4. The **Marker X Position** menu item is selected. Using the general purpose knob or the numeric input keypad, move the marker to a reference point (see Figure 2–21).

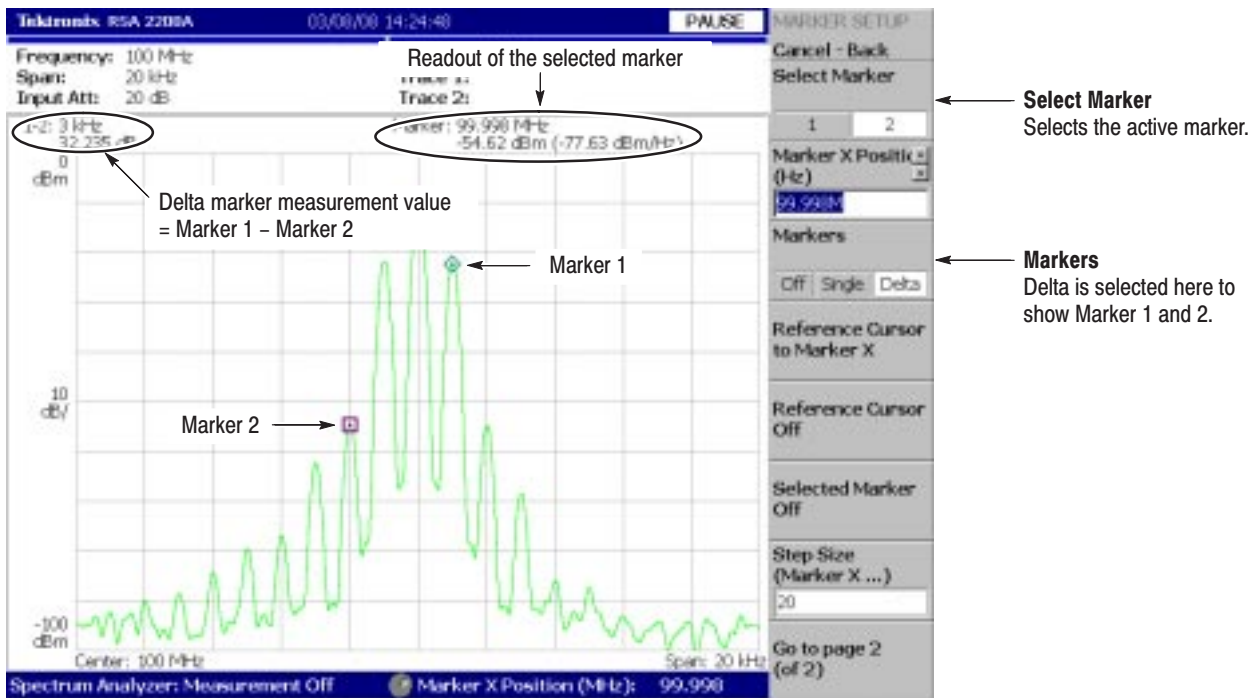

Figure 2-21: Measurement with the delta marker

5. Press the **Select Marker** side key (top) to select **2**, making Marker 2 active.

You can also select the marker using the **MARKERS: SELECT** key on the front panel. The **MARKERS: SELECT** key and the **Select Marker** side key have the same function.

6. The **Marker X Position** menu item is selected. Using the general purpose knob or the numeric input keypad, move the marker to a measurement point (see Figure 2-21).

The difference between the two marker positions is indicated in the upper left part of the screen:

7. Press the **Markers** side key to select **Single**.

The analyzer returns to the single marker mode.

Searching for the Peak

Measure the frequency interval between the maximum intensity spectrum and the peak to its left by using the delta marker and peak search functions together.

1. Press the **PEAK** key on the front panel.

Marker 1 moves to the maximum intensity spectrum.

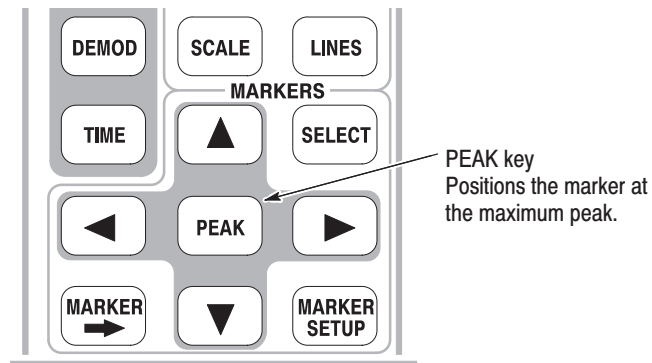

2. Press the **Markers** side key to select **Delta**.

The fixed marker (\diamond) appears at the active marker position.

3. Press the **Select Marker** side key to select **2**, making Marker 2 active.
4. Press the marker right key (\blacktriangleright) to move the marker to the next signal peak to the right. Try it several times.
5. Press the marker left key (\blacktriangleleft) to move the marker to the next signal peak to the left. Try it several times.
6. Using the marker left or right key, put the marker to the measurement peak.

The difference between the two marker positions is shown in the upper left part of the screen (see Figure 2–22).

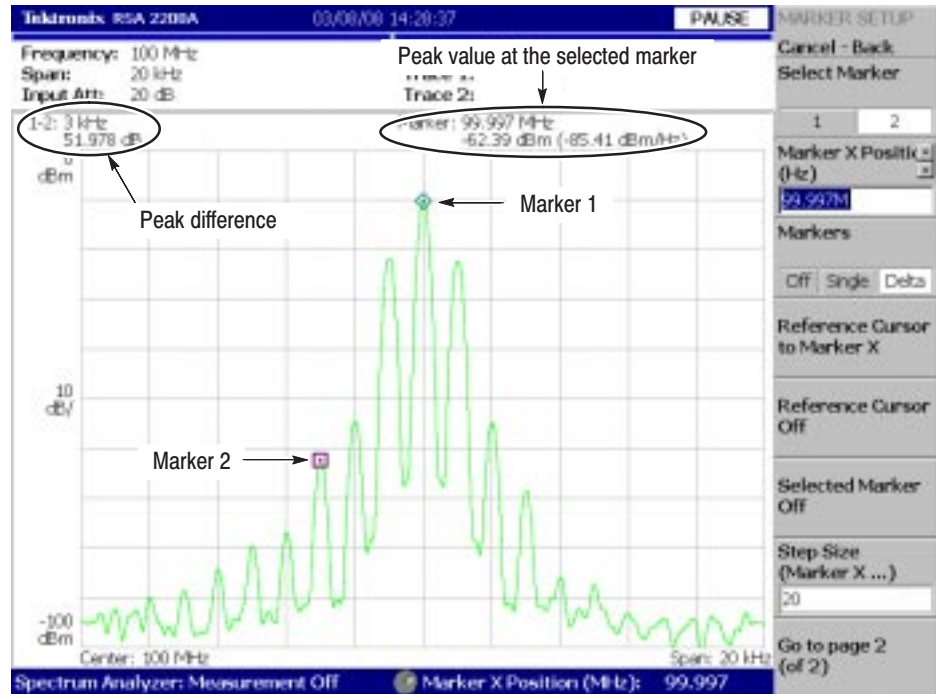

Figure 2–22: Searching for the peak

7. Press the **Markers** side key to select **Off**. Both markers disappear.

Using Averaging and Comparison Displays

This section describes how to use the averaging function, which displays the waveform with reduced noise. The averaged waveform can be displayed with the original waveform.

Averaging

There are several averaging methods; select RMS (Root-Mean-Square) in this example.

1. Press the **TRACE/AVG** key.

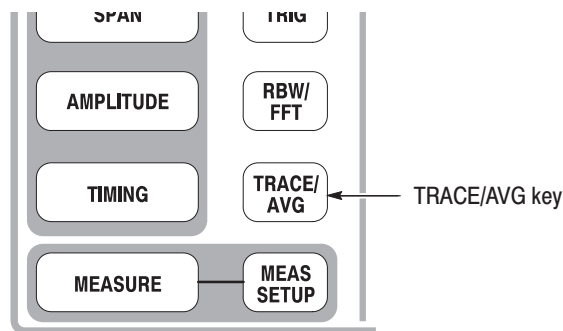

2. Press the **Trace Type** side key to select **Average**.
3. Press the **Number of Averages** side key to specify how many traces are accumulated to create the averaged waveform.

In this example, enter 64 with the numeric keypad.
Press **6 4 ENTER** in order.

4. Press the **RUN/STOP** key on the front panel to acquire waveform.

The averaged waveform is displayed on the screen. The average count is shown in the upper right part of the screen (see Figure 2–23). When the waveform is acquired in the free run mode, the averaging is done with exponential RMS (root-mean-square). This method continues the average with an exponential weighting applied to old values, using the number of averages (64 in this example) as the weighting factor.

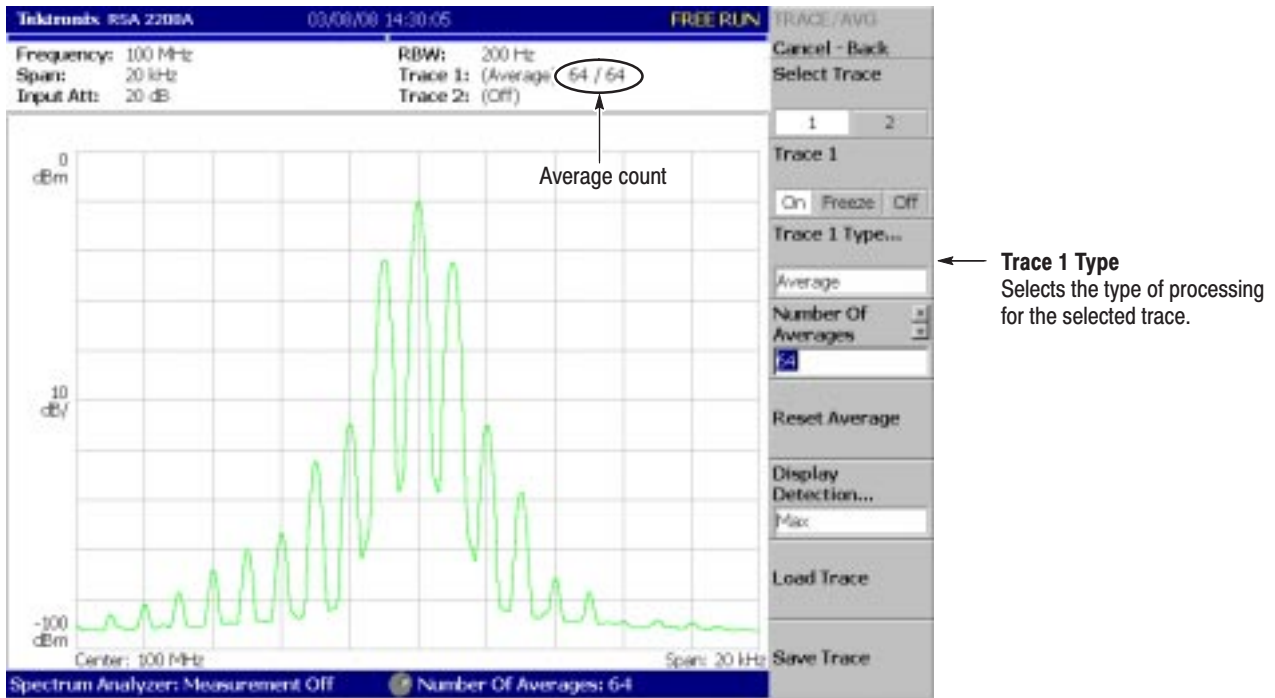

Figure 2–23: Comparing a new waveform with an averaged waveform

5. Press the **Reset Average** side key to restart averaging.

Comparison Display

You can display two different types of traces concurrently on the screen. In this procedure, you will display the currently acquired waveform and an averaged waveform for comparison.

1. Press the **TRACE/AVG** key on the front panel.
2. Make sure that **1** (Trace 1) is selected in the **Select Trace** menu item.
3. Press the **Trace Type...** side key and select **Normal** to define Trace 1 as the currently acquired waveform.
4. Press the **Select Trace** side key to select **2** (Trace 2).
5. Press the **Trace 1 Type...** side key and select **Average** to define Trace 2 as the averaged waveform.
6. Press the **RUN/STOP** key on the front panel to acquire waveform.

The currently acquired waveform (Trace 1 in yellow) is displayed with the averaged waveform (Trace 2 in green). See the display in Figure 2–24.

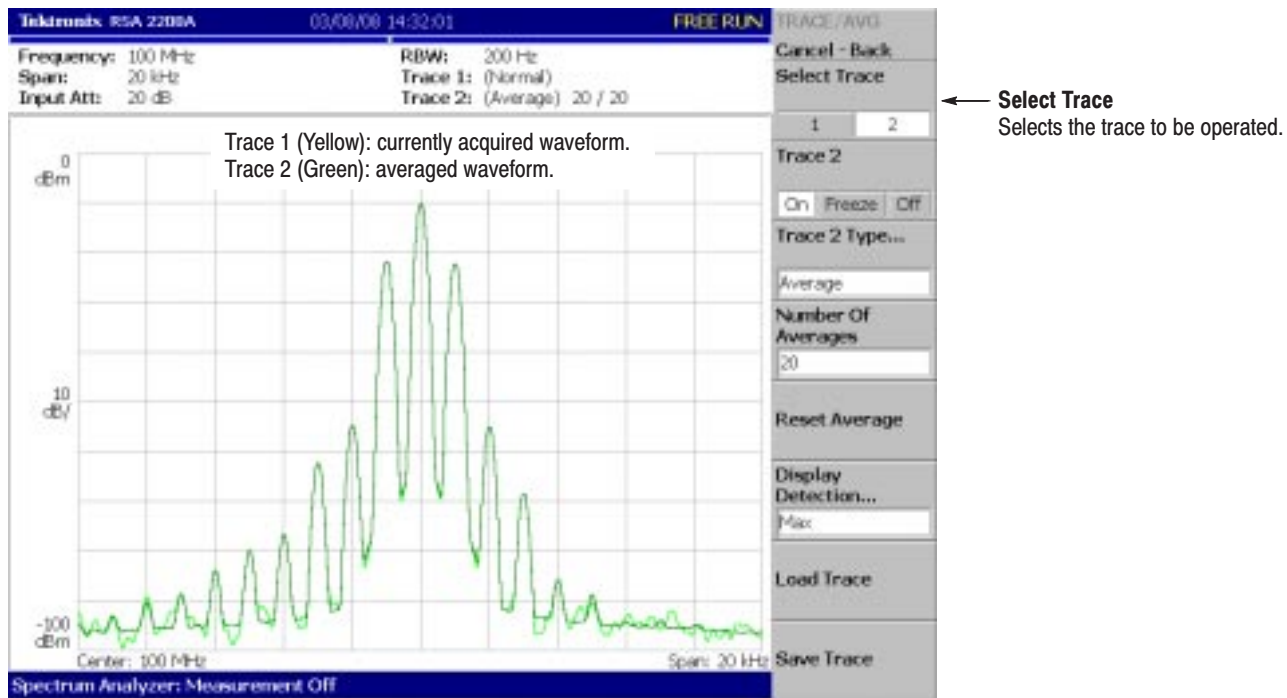

Figure 2–24: Comparison display with averaged waveform

7. Press the **Trace 2 Type...** side key again and select **Off** to remove Trace 2.

Displaying a Spectrogram

The spectrogram view is a useful tool to observe spectrum changes in time series in a three-dimensional view. The horizontal and vertical axes indicate frequency and frame number, respectively, and the color axis represents amplitude.

Display the spectrogram using the following steps:

1. Press the MODE: S/A key.

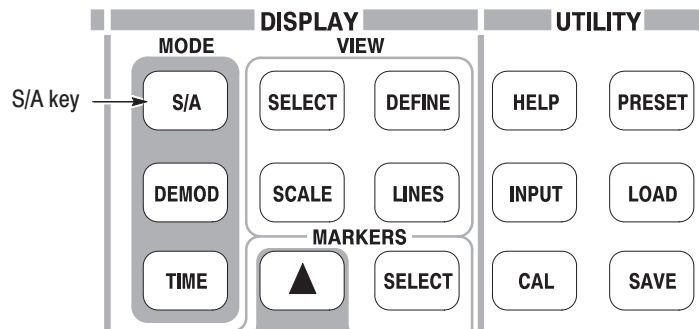

2. Press the **S/A with Spectrogram** side key.
3. If no waveform is displayed, press the **RUN/STOP** key to acquire data.

The spectrum and spectrogram are displayed concurrently (see Figure 2–25).

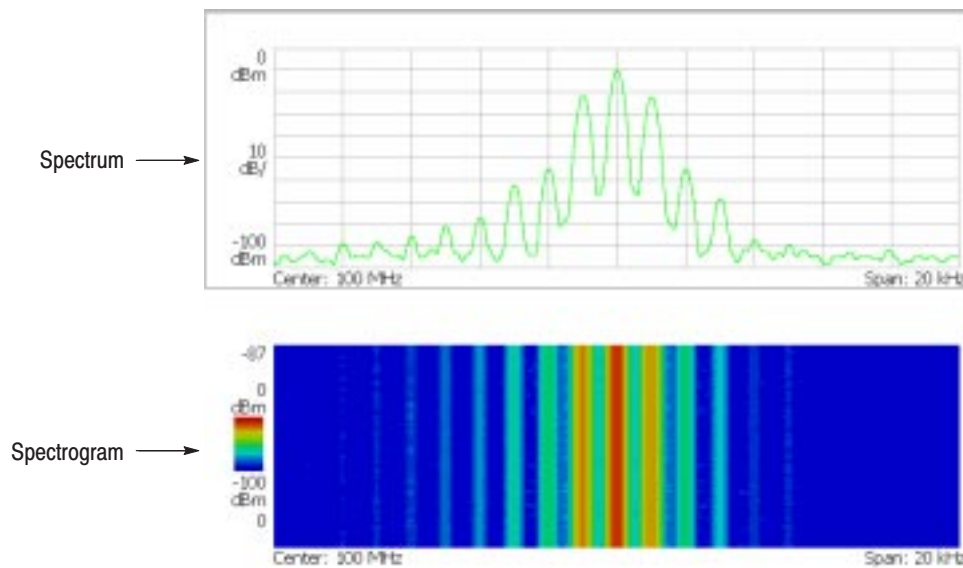
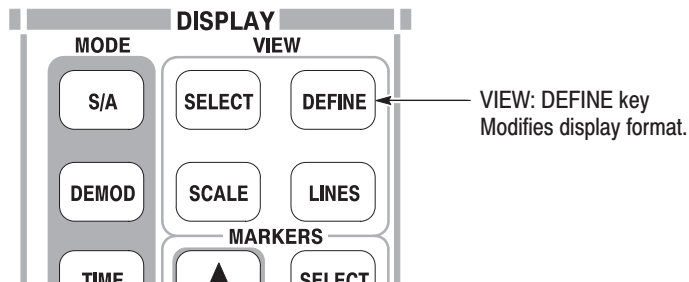

Figure 2–25: Concurrent display of spectrum and spectrogram

4. Display the spectrum and spectrogram side-by-side:
 - a. Press the VIEW: **DEFINE** key.



- b. Press the **View Orientation** side key to select **Tall**.

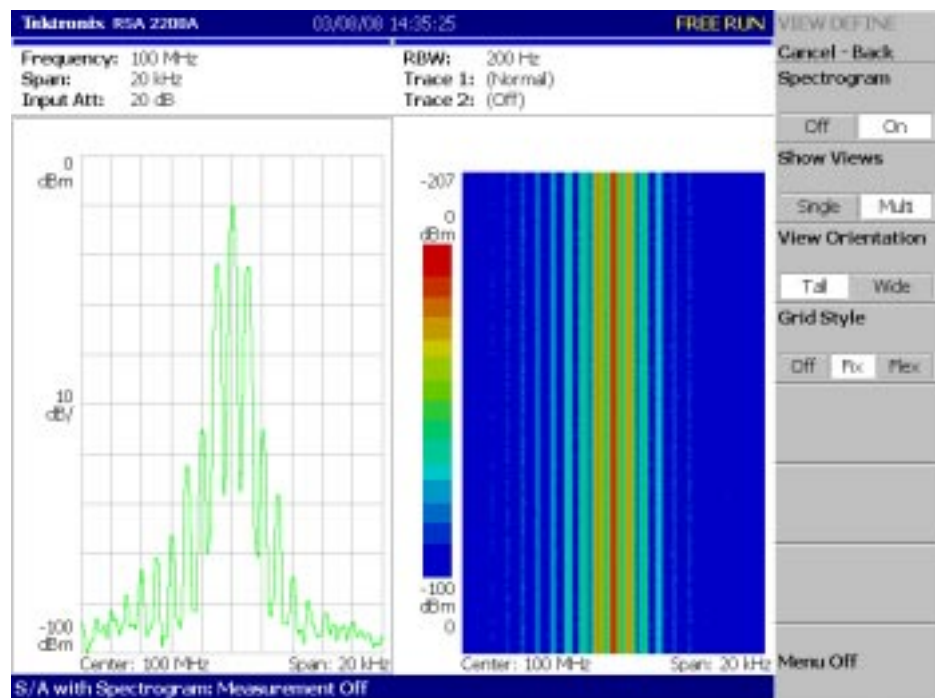

Figure 2-26: Tall display of spectrum and spectrogram

- c. Press the **View Orientation** side key to select **Wide**.

5. Display spectrogram only:

- a. Press the VIEW: **SELECT** key and then select the spectrogram on the display.

The selected view is framed in white on screen.

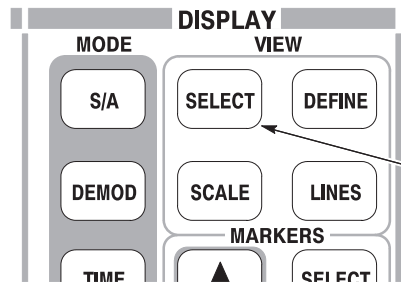

VIEW: SELECT key
Selects a view to operate.
(The selected view is surrounded by a white frame)

- b. Press the VIEW: **DEFINE** key and then press the **Show Views** side key to select **Single**.

Only the spectrogram is displayed (see Figure 2–27).

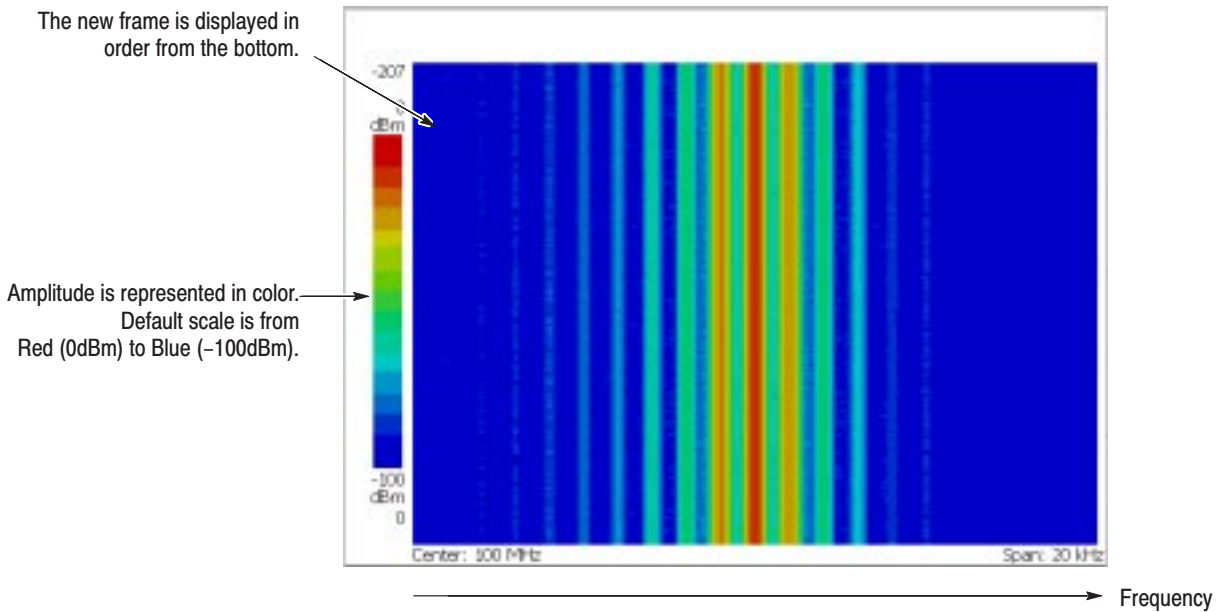

Figure 2–27: Spectrogram view

- c. Press the **Show Views** side key again to return to **Multi**.

Spectrum Analysis

There are several measurement items in the spectrum analysis, such as ACPR (Adjacent Channel Leak Power Ratio), C/N (Carrier vs. Noise Power Ratio), and OBW (Occupied Band Width). These items enable you to perform measurements using simple key operations. Here measure channel power and carrier frequency as examples.

Measuring Channel Power

1. Press the **MEASURE** key on the front panel.

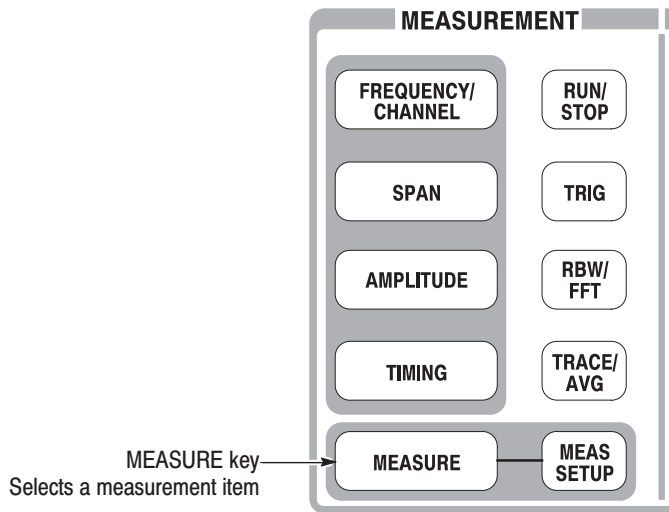

Measurement items are displayed in the menu on the right side of the screen.

2. Press the **Channel Power** side key.

A band power marker, indicating measurement range, is displayed on the spectrum waveform. The measurement result is displayed below the waveform (see Figure 2–28).

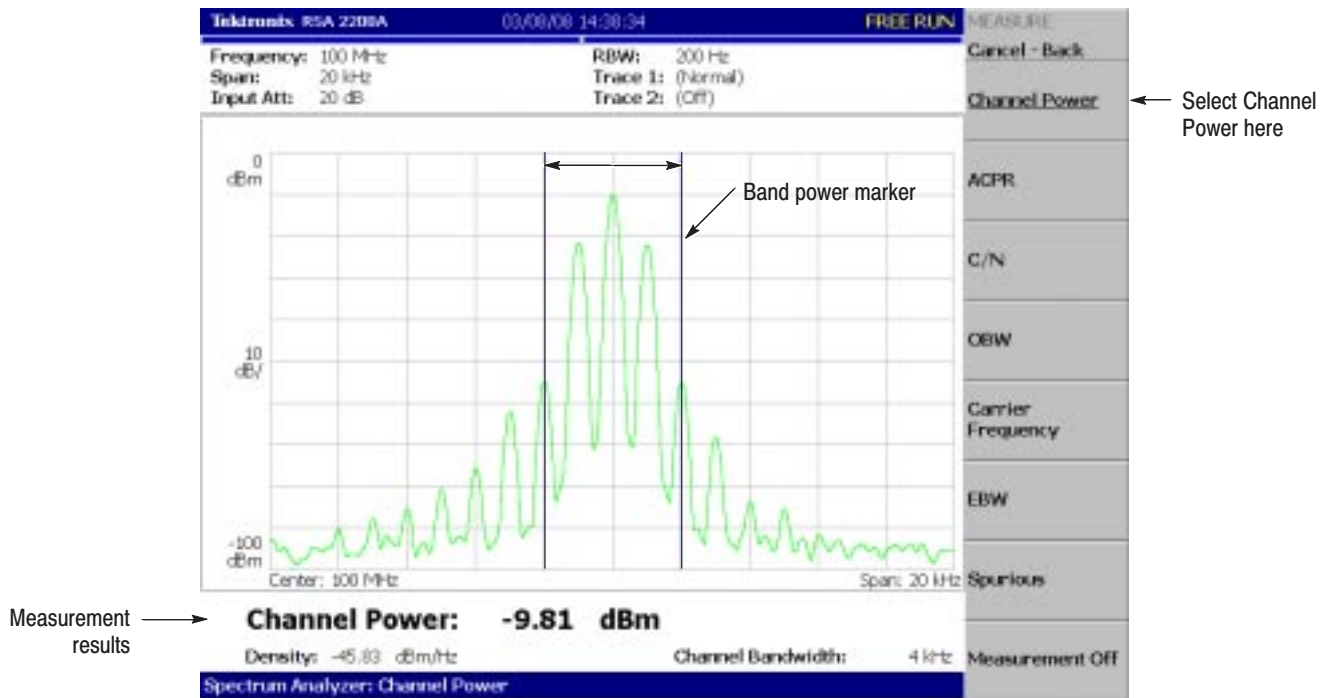

Figure 2–28: Channel power measurement

Changing a Measurement Parameter

Change a measurement parameter:

1. Press the **MEAS SETUP** key on the front panel.
2. The **Channel Bandwidth** menu item is selected. Using the general purpose knob, set the measurement range to 40 kHz for example. See the display in Figure 2–29.

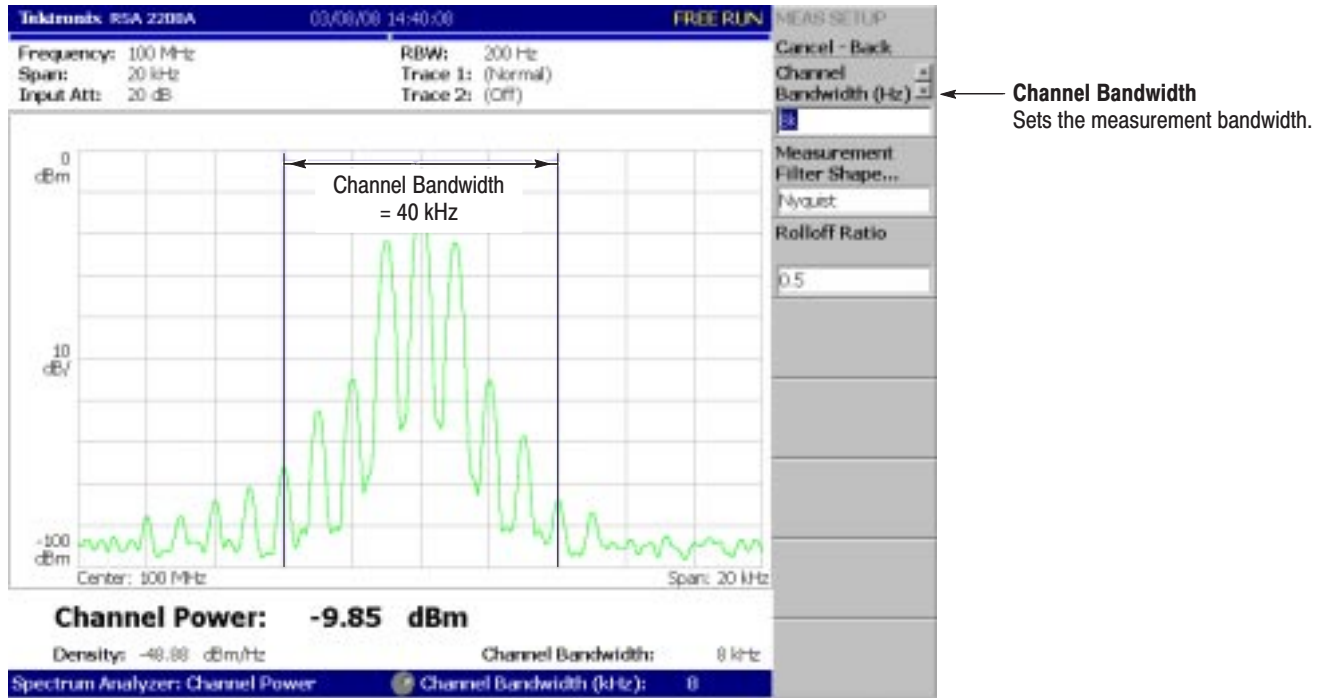

Figure 2–29: Channel power measurement (Channel Bandwidth = 40 kHz)

Measuring Carrier Frequency

Carrier frequency can be measured accurately, using the counter function:

1. Press the **MEASURE** key on the front panel.
2. Press the **Carrier Frequency** side key.

The measurement result is displayed at the bottom of the screen (see Figure 2–30).

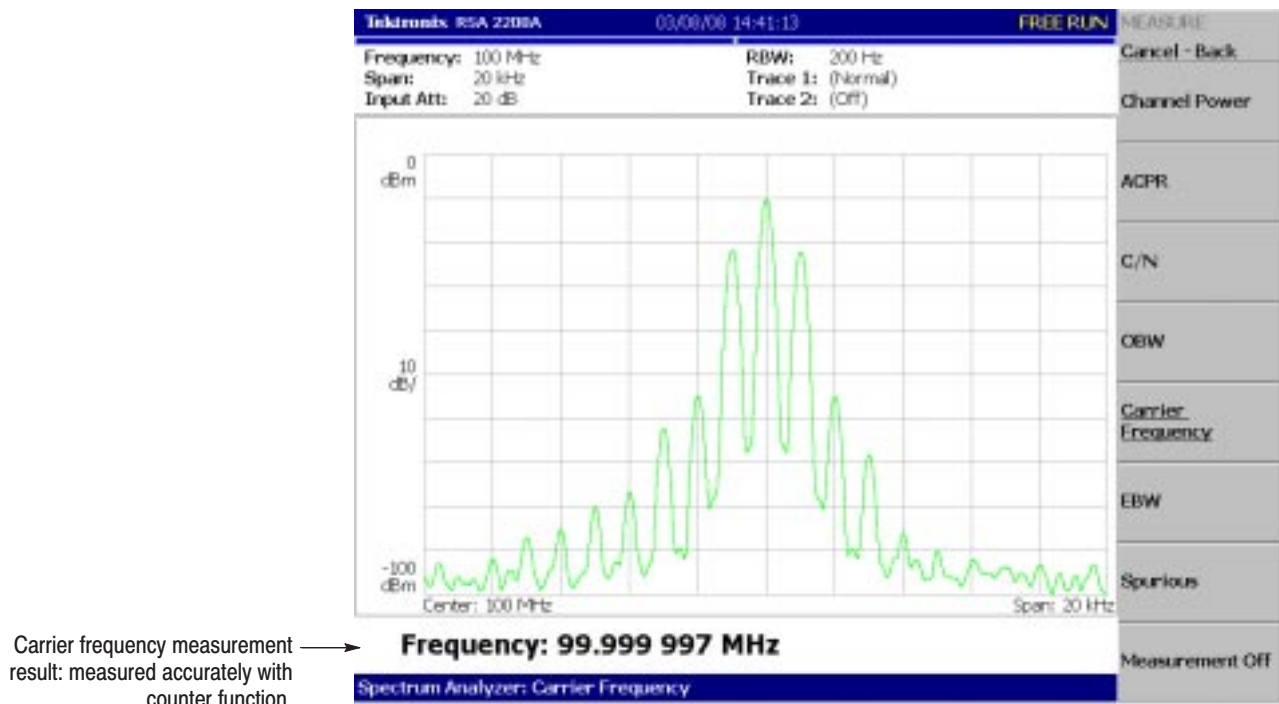

Figure 2–30: Carrier frequency measurement

Modulation Analysis

This section describes how to analyze a modulated signal. Settings are the same as those in the previous section; center frequency at 100 MHz, span of 20 kHz, and amplitude of 0 dBm.

Selecting Analysis Mode

The analyzer functions are classified into three functional groups, selected using the Mode keys (see Figure 2–31):

- Spectrum analysis **MODE: S/A**
Performs general spectrum analysis. All operations in the tutorial up to this point have been performed in this mode.
- Modulation analysis **MODE: DEMOD**
Performs analog and digital (Option 21 only) modulation analyses.
- Time analysis **MODE: TIME**
Performs time characteristic analysis, including CCDF measurement.

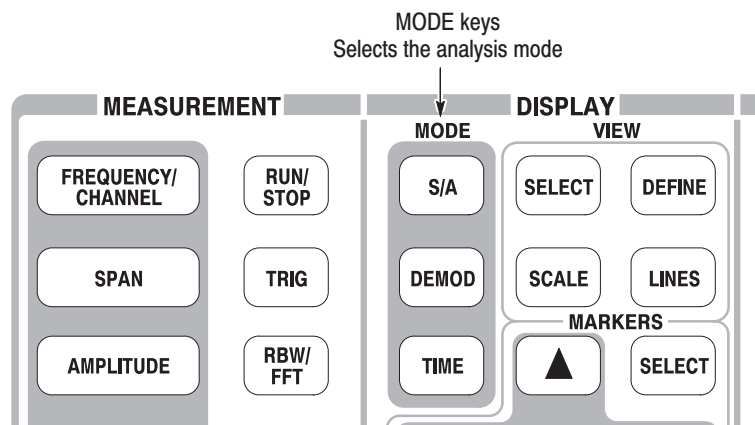

Figure 2-31: MODE keys

The measurement procedures for modulation analysis and the time analysis are similar. Select the analog modulation analysis here:

1. Press the **DEMOD** key on the front panel.
2. Press the **Analog Demod** side key.

Selecting a Measurement Item

Observe an AM signal change in time series as an example.

1. Press the **AM Demod** side key.
2. Press the **MEAS SETUP** key on the front panel to set the measurement parameter.
3. Press the **RUN/STOP** key to acquire the signal (see Figure 2–32).

Three views are displayed on the screen in the Demod mode:

- *Overview:* All data of the specified block are displayed in the time domain. The measurement range indicated by the green underline is specified in this view.
- *Main view:* Displays the measurement result and waveform of the range specified in the overview (they may be displayed in separate views). In this case, level changes of I and Q signals are displayed as the yellow and green traces, respectively, in the main view.
- *Subview:* Spectrum is displayed as an auxiliary view by default. You can specify the range in the overview to create the spectrum for the subview.

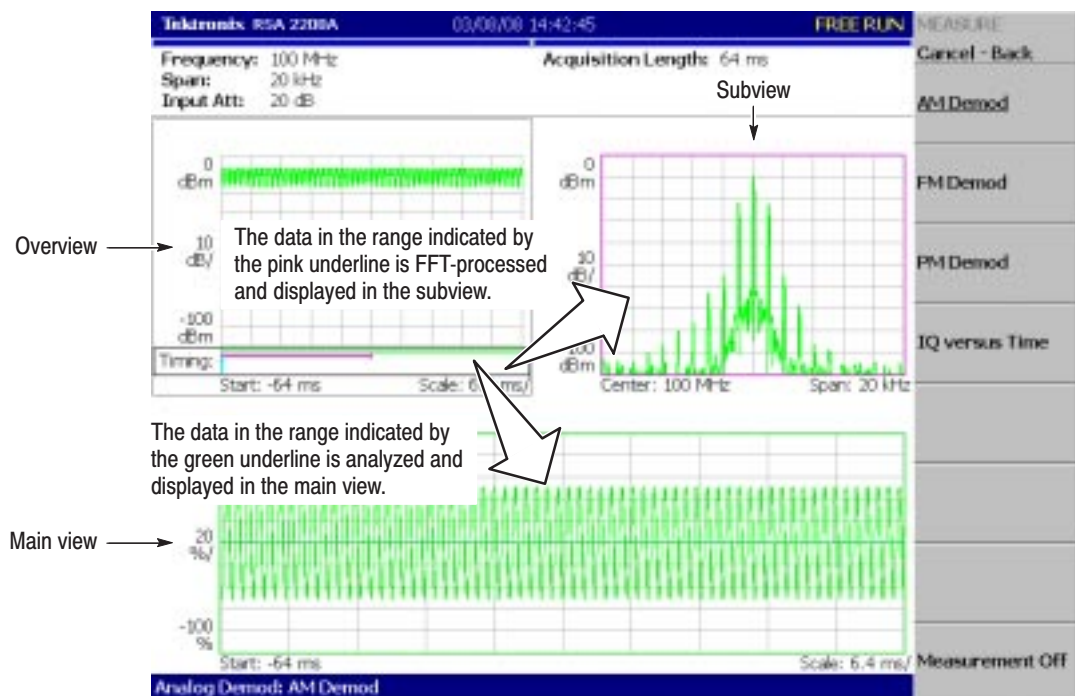
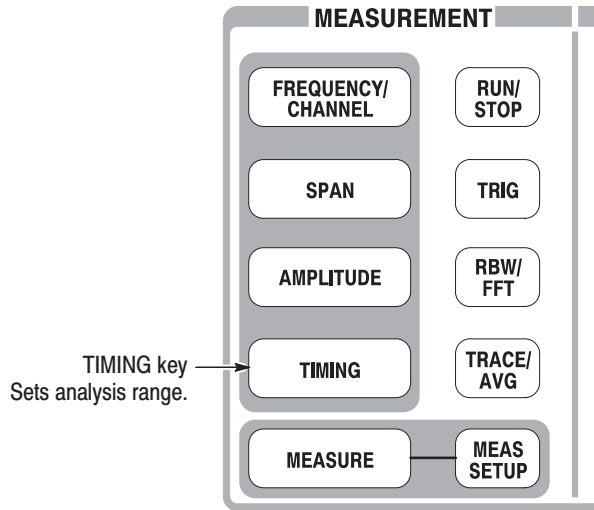

Figure 2–32: AM signal measurement

Setting Analysis Range

Set an analysis range, which will be displayed with a green underline in the overview.

1. Press the **TIMING** key on the front panel.



Two vertical green lines appear, indicating the analysis range, shown in Figure 2–33.

2. Press the **Acquisition History** side key to specify the number of the block to be analyzed. Leave it at "0" (the latest block), its default value.
3. Press the **Analysis Length** side key and specify the time length of the analysis range. For example, enter **32 ms** using the numeric keypad.
4. Press the **Analysis Offset** side key and specify the starting point of the range. For example, enter **24 ms** using the numeric keypad.

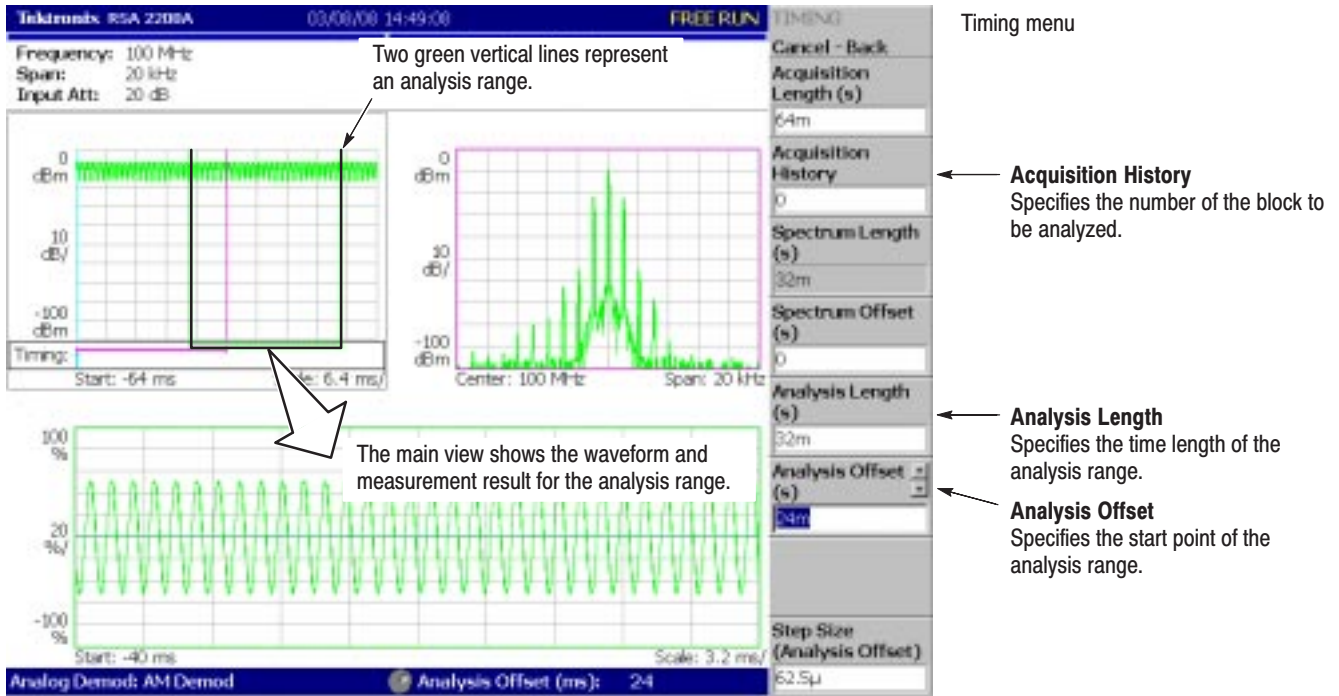

Figure 2-33: Analysis range settings

Setting the Acquisition Length

One frame consists of 1024 data points and one block consists of several frames. Data are acquired in block units in the Demod mode. The number of frames in one block is referred to as block size. Frame and block size are shown in Figure 2–34.

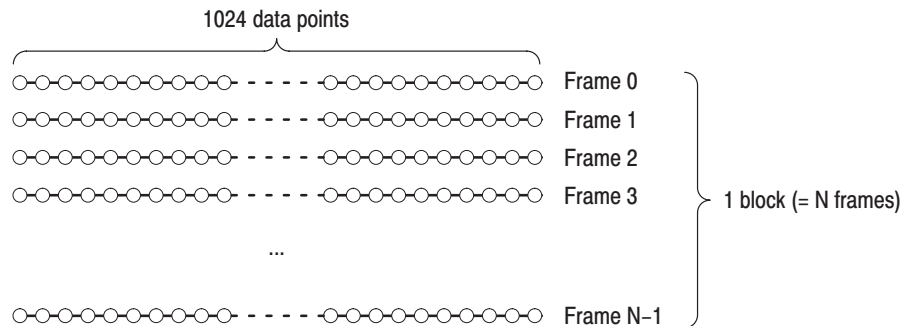

Figure 2–34: Frame and block

Suppose that one block contains N frames. The acquisition length for a block is calculated using this equation:

$$(\text{One block acquisition length}) = N \times (\text{One frame acquisition length})$$

One block acquisition length is set using **Acquisition Length** in the Timing menu. One frame acquisition length is set internally, depending on span, and displayed in **Spectrum Length** in the Timing menu.

To set the acquisition length, perform the following steps:

1. Press the **TIMING** key on the front panel.

By default, Acquisition Length is set to 64 ms and Spectrum Length 32 ms. The number of frames in a block is $64 \div 32 = 2$.

2. Press the **Acquisition Length** side key to change the value. For example, set 256 ms by turning the knob (see Figure 2–35).

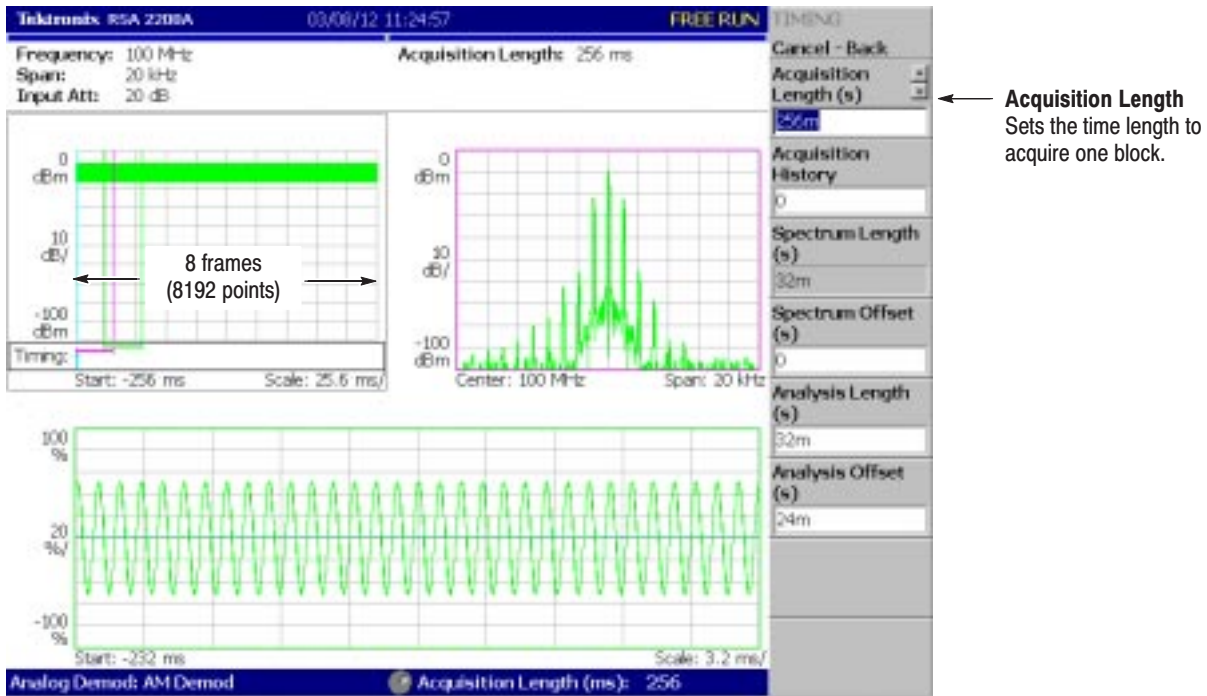

← **Acquisition Length**
Sets the time length to acquire one block.

Figure 2-35: Changing the acquisition length

In this case, Acquisition Length is 256 ms and Spectrum Length 32 ms, so the data is displayed in the overview for $256 \div 32 = 8$ frames (8192 points). The green underline indicating the analysis range gets narrower than the previous setting: one block = 2 frames.

Displaying Single View and Changing Scale

Although three views are normally displayed in the Demod mode, you can select one view to display full screen. This section describes how to display one view and change the vertical and horizontal scales using the VIEW keys.

1. Press the **RUN/STOP** key to stop data acquisition and observe the waveform.
2. Press the **VIEW: SELECT** key to select the main view. The selected view is surrounded with a white frame.

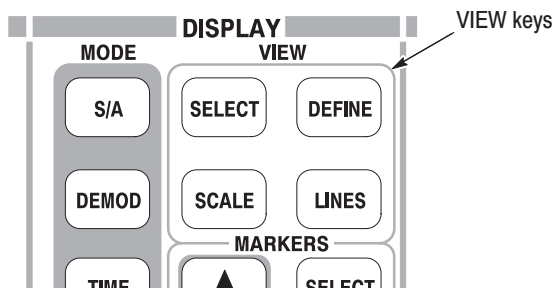

3. Press the **DEFINE** key, and then the **Show Views** side key, shown in Figure 2–36, to select **Single**.

Only the main view is displayed, with the size enlarged on the screen.

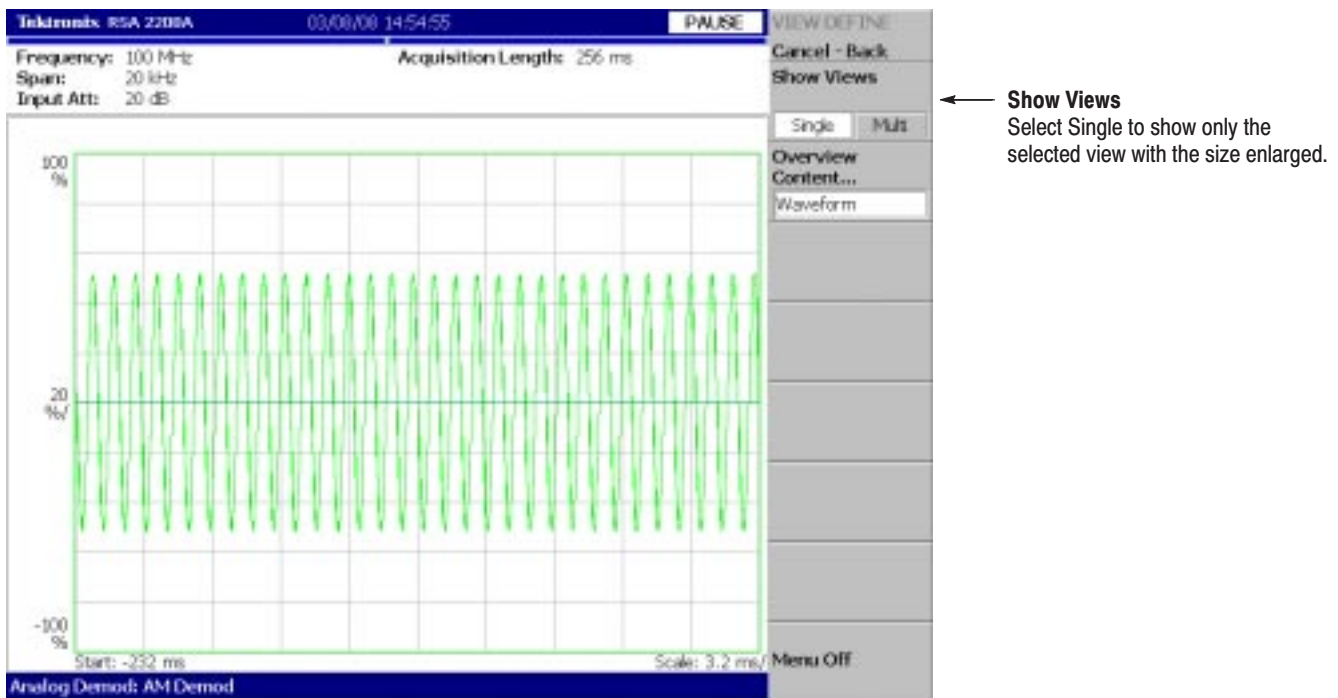

Figure 2–36: Single view display

4. Change the scale:
 - a. Press the **SCALE** key in the VIEW area.
 - b. Press the **Horizontal Scale** side key and change the scale of the horizontal axis (see Figure 2–37). Try several settings by turning the general purpose knob; observe the changes in the display.
 - c. Press the **Vertical Scale** side key and change the vertical axis scale. Try several settings by turning the knob; observe the changes in the display.

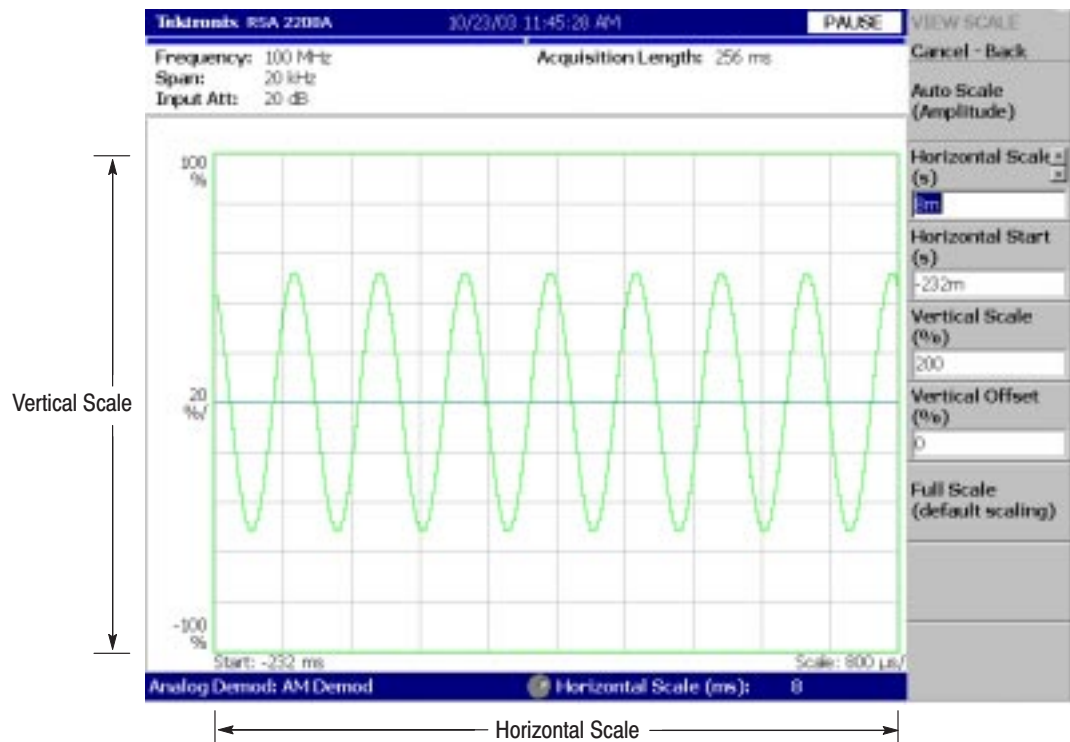

Figure 2–37: Scale settings

Completing the Measurement

Complete the measurement with the following procedure:

1. Press the **MEASURE** key on the front panel.
2. Press the **Measurement Off** side key.

The display returns to the spectrum view. However, the analysis mode is still in the Demod mode.

Using Windows 98

This analyzer operates under Windows 98. You can switch to a Windows 98 desktop screen or execute a Windows 98 application program.

Connecting a Mouse and a Keyboard

Connect a USB mouse and a USB keyboard to the USB ports on the side panel. You can connect them to either or both ports. You can also connect the mouse to the USB port on the keyboard.

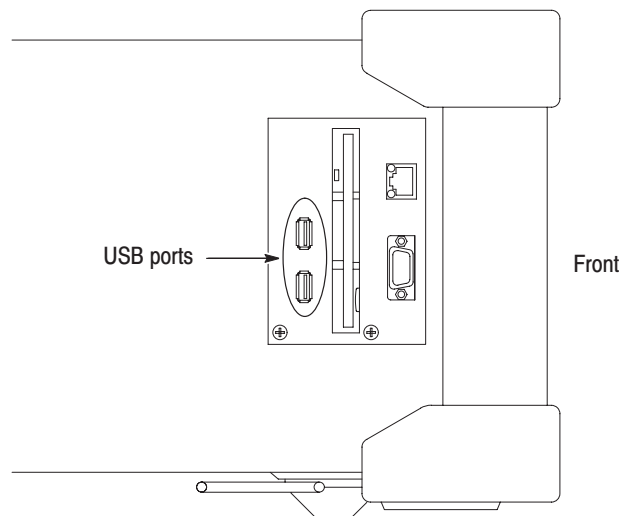

Figure 2-38: USB ports (side panel)

Displaying Windows 98 Desktop

Display the Windows 98 desktop on screen of the analyzer with these steps.

1. With the mouse, move the pointer to the bottom of screen. The task bar appears.
2. Place the pointer on the icon indicating the analyzer model name (RSA2203A or RSA2208A) located on the task bar, and click on it with the right button of the mouse. A menu opens.

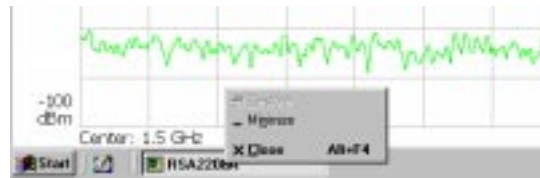

Figure 2-39: Displaying Windows 98 desktop

3. Select **Close** from the menu.

The analyzer system program stops, and the Windows 98 desktop displays.

Returning to the Analyzer View

To switch from the Windows desktop screen to the analyzer display, from the task bar, select **Start** → **Program** → **RSA2200A**. The analyzer program starts.

Turning Off the Power

When you have completed the measurements, turn off the power:

1. Press the **ON/STANDBY** switch at the lower left of the front panel.

The shutdown process of Windows 98 runs and the power source goes to standby state, with the orange LED on.

2. Turn off the signal generator.

You have now completed the tutorial.

Theory of Operation

Theory of Operation

This section describes the electrical operation of the RSA2203A and RSA2208A using the major circuit blocks or modules as shown in Figure 9–1.

RF Input Circuit

The RF input circuit block consists of a relay for signal switching (Input Relay), Step Attenuator, Programmable Band-pass Filter (RSA2208A only), and a control circuit for these components. This block adjusts the level of input signal as appropriate in accordance with reference level settings, and sends the signal to the 1st converter.

Input Relay located just after the RF INPUT connector is for calibration signal switching. It switches to pass the internal calibration signal when self gain-calibration is selected. The Step Attenuator that follows is the Programmable Attenuator of 10 dB/step, and attenuates the input signal up to –50 dB. The Band Relay performs switching of the signal paths between RF1 and RF2/3 bands.

In RF2/3 band, bandwidth of the signal is limited with a Programmable Band-pass Filter to avoid occurrence of images and/or spurious signals. This Programmable BPF is able to adjust its center frequency in the range of 3.5 GHz to 8 GHz, and adjustment to the center frequency is achieved with the current output from the A100 Interconnection board. In a same way, other attenuators and relays are controlled with currents from the A100 Interconnection board.

On the A100 Interconnection board, various components are installed, such as: a group of registers to save the setup data from Hardware Controller, driver circuits for relays and attenuators, D/A converter circuit for generation of tuning current to Programmable BPF, ALC circuit to maintain the amplitude of the calibration signal at a constant level, and other components.

RF3 Module

The RF3 module contains the 1st Converter, 1st Local Oscillator, 1st IF Amplifier, and other components. After level adjustment in the RF input circuit, the input signal is applied to the 1st Converter. Mixed with 1st LO signal, the input signal is frequency-converted into 1st IF signal of 4232 MHz. Oscillation frequency of 1st Local Oscillator is controlled with a synthesizer (RF4 module) in this case, so that 1st IF signal is always maintained at 4232 MHz. After this, the 1st IF signal passes through the 1st IF Amplifier that has a gain of approximately 10 dB, and is sent to the 2nd Converter (RF2 module).

In baseband (Option 05), an input signal enters the 1st Converter. Then the signal path is switched with a relay and the signal is sent directly to the A10 A/D board for A/D conversion. In RF1 band, an input signal goes through all converters (1st, 2nd, and 3rd). In RF2/3 band, an input signal is directly frequency-converted by the 1st Converter into the 2nd IF signal of 422 MHz, then sent directly to 3rd Converter, bypassing the 2nd Converter.

RF2 Module

The RF2 module consists of the 2nd Converter, 3rd Converter, and 2nd Local Oscillator. The 1st IF signal sent from the 1st Converter passes through a Band-pass Filter and a Low-pass Filter for removal of unnecessary frequency bands. After this, the 1st IF signal enters the 2nd Converter. In the 2nd Converter, the 1st IF signal is mixed with the 2nd LO signal and frequency-converted into the 2nd IF signal of 422 MHz. Same with the case of 1st Local Oscillator, frequency of 2nd Local Oscillator is controlled with a synthesizer circuit (RF4 module) to stabilize LO output frequency.

The 2nd IF signal is sent to the 3rd Converter. In the 3rd Converter, the signal is mixed with the 3rd LO signal and frequency-converted into the 3rd IF signal of 39 MHz. After selected with a band-switching relay located at the input section of the 3rd Converter, the 2nd IF signal directly sent from the 1st Converter in RF2/3 band mode is also frequency-converted into the 3rd IF signal of 39 MHz.

RF5 Module

The RF5 module consists of the 3rd IF Gain block, Oscillator block, and 10 MHz Reference Oscillator. The Oscillator block contains the 3rd Local Oscillator and an oscillator of Sampling Clock signal to be supplied to A/D Converter.

The Gain block consists of a Step Amplifier of 10 dB/step with the maximum gain of 50 dB and a Step Attenuator with the maximum attenuation of -30 dB. This block maintains the 3rd IF signal to be sent to A/D Converter at an appropriate level, and adjusts the accuracy of conversion gain.

Both the 3rd LO signal and A/D clock signal generated in the Oscillator block are highly stabilized signals locked with a 10 MHz reference signal, and are output to the 3rd Converter and A10 A/D board, respectively.

For Option 10, the 10 MHz Reference Oscillator is configured around an OCXO (Oven Controlled Crystal Oscillator) with extremely high frequency stability. It is used as the reference clock source for all the oscillators including the frequency synthesizer circuits.

Circuits such as the input circuit of external 10 MHz reference signal, internal/external reference switching circuit, and 10 MHz reference output circuit are also contained in the RF5 module.

RF4 Module

The RF4 module is comprised of synthesizer circuits. The synthesizer consists of multiple PLL Oscillator units of low noise type locked with the 10 MHz reference signal. By changing the oscillation frequency of these PLL Oscillator in fine steps, 1st LO frequency can be tuned in the range of 4 GHz to 8 GHz while maintaining a good level of C/N.

The synthesizer also contains a circuit for generation of a 50 MHz signal to be used as the reference for the calibration signal, PLL circuitry of the 2nd Local Oscillator, a circuit for generation of DDS signal to be used as the reference signal for the 3rd Local Oscillator, and other components.

A10 A/D Board

Analog signals such as the IF signal sent from the Down Converter block are converted into digital format with a high-speed, high-accuracy A/D converter, and sent to the A41 SRAM board via the A50 Mother board.

The A/D board contains input circuits for three analog signals: IF signal, baseband signal (optional). Each input circuit is equipped with a Buffer Amplifier, a Step Amplifier, and a Step Attenuator to maintain the signal level as appropriate, as well as a BPF or LPF for removal of signal components within unnecessary frequency bands.

A41 SRAM Board

The A41 SRAM board consists of a Digital Tuner, some Decimation Filters, and SRAM-based Capture Memory. It also interfaces between the data block and the Windows system.

The digital output of the A10 board is frequency-tuned and decimated in the Digital Tuner. The Digital Tuner output is sent to the Decimation Filters. The filters are used for higher decimation rate. In these filters, the signal bandwidth is limited by the span setting.

IF Level Trigger signal is generated on this board. Time domain data is saved in the SRAM-based capture memory. The Capture Memory is connected to the PCI local bus through the dual port SRAM. The TRIG IN and OUT connectors located on the rear panel are connected with this board.

This board also contains a microprocessor that controls various software settings and various types of hardware as well as peripheral devices such as ROM/RAM.

Power Supply Circuit

The power supply circuit consists of two units of AC/DC Converter (Power Supply 1 and 2) energized from AC power line, and A70 DC power board, which regulates the output voltages of AC/DC converter units and distributes the regulated outputs to each of the boards and fans.

Note that Power Supply 1 and 2 units have different output voltage specifications. The Power Supply 1 output voltages are +5V/+15V/-15V/+24V; the Power Supply 2 output voltages are +5V/+12V/-12V/+3.3V.

The A70 DC Power board is equipped with multiple DC/DC converters, and based upon the output voltages supplied by the Power Supply 1 and 2 units, power voltages other than above are generated on this board. On the A70 DC Power board, LED indicators and test points are provided to facilitate checking that all the power supply voltages are output normally.

Standby Power and On/Standby Switch

Power Supply 3 is the standby power supply unit which continuously supplies power to some areas of the CPU board and the 10 MHz Reference Oscillator even if the Power Switch on the main unit is turned off (standby mode). Unless the Principal Power Switch (located on the rear panel) is turned off, Power Supply 3 continues to output power voltages. Because of this, remove AC power before opening the enclosure to perform servicing inside.

The Standby Power Supply always maintains the ACPI (power control) function for the CPU board to be active. With this function, the CPU board recognizes the On status of the On/Standby Switch even in the power-off condition and is able to output the power-on signal to Power Supply 1 and 2 units.

For Option 10, to enable accurate high-frequency measurements just after power-on, power is also supplied to the 10 MHz Oscillator (OCXO) from Standby Power Supply unit.

A50 Mother Board

The A50 Mother board distributes power to all boards/modules, as well as interfacing of control signals and data with the CPU. Other devices such as the PCI Bridge, Local Bus Controller, and Bus Buffer for CPU bus expansion are also on the A50 Mother board.

A60 Front Key Board

A microprocessor for key control is installed on the A60 Front Key board. Various processes such as serial conversion of key scan, key code, and signal transmission to the CPU board are performed on this board.

A62 Front Connection Board

The A62 Front Connection board interfaces with peripheral devices such as HDD, FDD, LCD, USB, and keys with the CPU board.

The GPIB controller is also installed on the Front Connection board, and its output bus is connected to the GPIB connector located on the real panel via the A50 Mother board and the A70 DC Power board.

Performance Verification

Performance Verification

Two types of Performance Verification procedures can be performed on this product; *Brief Procedures* and *Performance Tests*. You may not need to perform all of these procedures, depending on what you want to accomplish.

- To rapidly confirm that the analyzer functions properly and was adjusted properly, do the brief procedures under *Functional Tests and Diagnostics*, which begin on page 4–3.

Advantages: These procedures are quick to do, require no external equipment or signal sources, and perform functional and accuracy testing to provide high confidence that the analyzer will perform properly. They can be used as a quick check before making a series of important measurements.

- If more extensive confirmation of performance is desired, do the *Performance Tests*, beginning on page 4–9, after doing the *Functional Tests* and *Diagnostics* just referenced.

Advantages: These procedures add direct checking of warranted specifications. They require more time to perform and suitable test equipment is required. (Refer to *Equipment Required* on page 4–10.)

Conventions

Throughout these procedures the following conventions apply:

- Each test procedure uses the following general format:

Title of Test

Equipment Required

Prerequisites

Procedure

- Each procedure consists of as many steps, substeps, and subparts as required to do the test. Steps, substeps, and subparts are sequenced as follows:

1. First Step

- a. First Substep

- First Subpart

- Second Subpart

- b. Second Substep

2. Second Step

- Instructions for menu selection follow this format:

FRONT PANEL KEY → **Side Menu Key** → **Submenu Key**.

For example, “Press MODE: **DEMODO** → **Digital Demod** → **Constellation**”.

“MODE: **DEMODO**” indicates the **DEMODO** key in the MODE menu area on the front panel.

- In steps and substeps, the lead-in statement in italics instructs you what to do, while the instructions that follow tell you how to do it.

In the example step below, “*Set the RSA2208A analyzer controls*” by doing “Press MODE: **DEMODO** → **Digital Demod** → **Constellation**”.

Set the RSA2208A analyzer controls:

Press MODE: **DEMODO** → **Digital Demod** → **Constellation**.

STOP. *The symbol at the left is accompanied by information you must read to do the procedure properly.*



Brief Procedures

The *Functional Tests* utilize the internal calibration signal as a test-signal source for further verifying that the analyzer functions properly.

The *Diagnostics* uses internal routines to verify that the instrument functions properly and passes the internal circuit tests.

The following section provides the details.

Functional Check

The analyzer has a built-in calibration signal source with amplitude of approximately -20 dBm and frequency of 50 MHz. Using this source, perform this quick functional check to verify that your instrument is operating correctly.

Equipment Required	None
Prerequisites	Power on the analyzer and allow a 20 minute warm-up before doing this procedure.

1. *Initialize the analyzer:*
 - a. Press the **SYSTEM** key on the front panel.
 - b. Press the **Reset All to Factory Defaults** side key.
2. *Check the system version and options:*
 - a. Press the **SYSTEM** key on the front panel.
 - b. Press the **Versions and Installed Options...** side key.
 - c. Check the version at the “Main System” field and the options in the option table.
3. *Check the display brightness:*
 - a. Press the **Cancel-Back** (top) side key.
 - b. Press the **Display Brightness** side key.
 - c. Change the value from 0 to 100% using the general purpose knob to check that the brightness changes normally.
4. *Display spectrum of the calibration signal:*
 - a. Press the **S/A** key on the front panel and then press the **Spectrum Analyzer** side key.
 - b. Press the **PRESET** key on the front panel to reset the analyzer.
 - c. Press the **INPUT** key on the front panel.
 - d. Press the **Signal Input Port...** side key to select **Cal**.
The spectrum of the calibration signal appears.
 - e. Check that “INPUT: CAL” and “FREE RUN” are displayed in the status indicator at the upper right of the screen (see Figure 4–1).

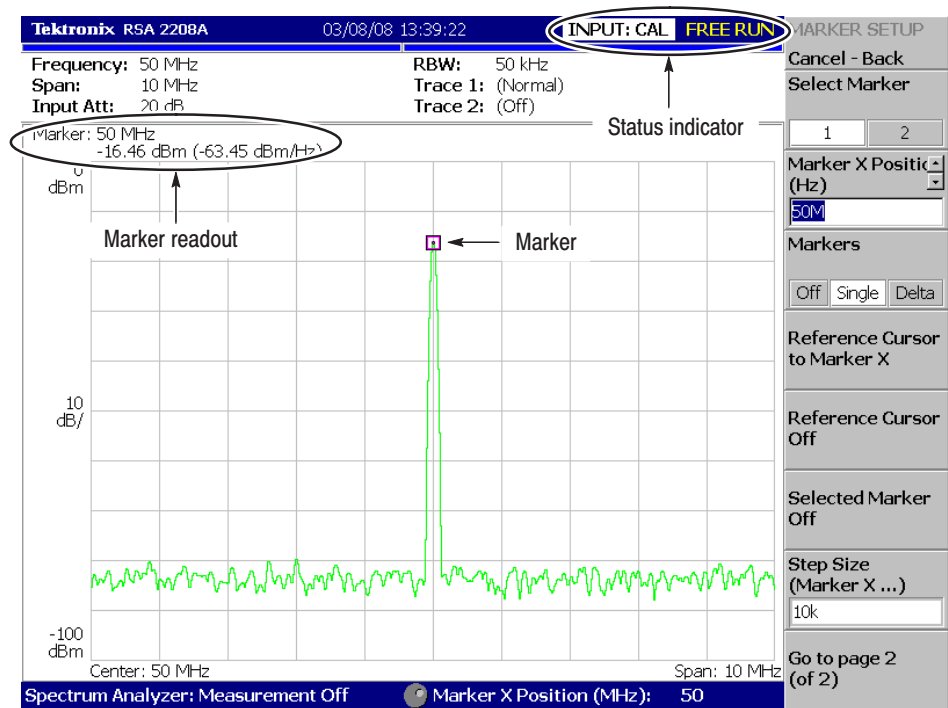

Figure 4-1: Spectrum of the calibration signal (50 MHz, -20 dBm)

5. Check the center frequency and peak amplitude using the marker:
 - a. Press the **PEAK** key on the front panel to place the marker on the peak (see Figure 4-1).
 - b. Check the marker readouts on screen. The frequency should be 50 MHz and the amplitude should be approximately -20 dBm.
 - c. Press the **MARKER SETUP** key on the front panel and then the **Markers** side key to select Off. Check that the marker disappears.
6. Check the RBW (Resolution Bandwidth) while changing the span setting.
 - a. Press the **SPAN** key on the front panel.
 - b. Confirm that the span is 10 MHz and the RBW is 50 kHz in the setup display on the upper part of the screen (see Figure 4-2).

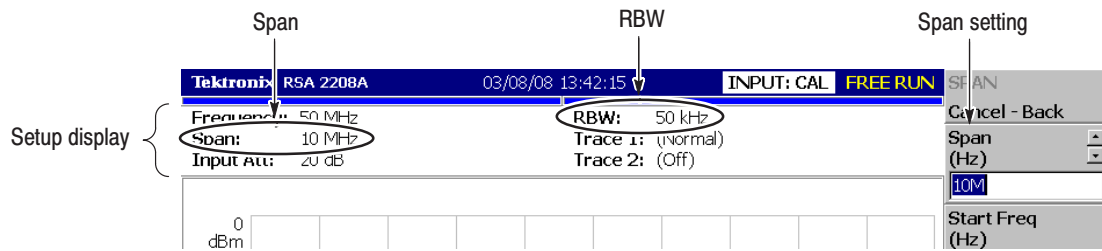

Figure 4-2: Setup display

- c. Using the general purpose knob, change the span setting as listed in Table 4-1 and check that the RBW is displayed correctly.

Table 4-1: Span and RBW

Span	RBW
10 MHz	50 kHz
5 MHz	20 kHz
100 kHz	500 Hz
1 kHz	20 Hz

- d. Using the numeric keypad, set the span back to 10 MHz. (Press **1** → **0** → **MHz**, in that order, on the keypad.)
7. *Check the reference level:*
- a. Press the **AMPLITUDE** key on the front panel.
 - b. Make sure that the reference level is set to 0 dBm with the **Ref Level** side key. Check that 0 dBm is displayed on the upper left side of the graticule (see Figure 4-3).
 - c. Use the general purpose knob to set the reference level to -30 dBm.
 - d. Confirm that A/D OVERFLOW is indicated in the red box at the top center of the screen. Make sure that -30 dBm is displayed on the upper left side of the graticule and that the spectrum waveform is distorted as shown in Figure 4-3.
 - e. Using the numeric keypad, set the reference level back to 0 dBm. (Press **0** → **ENTER**, in that order, on the keypad.)

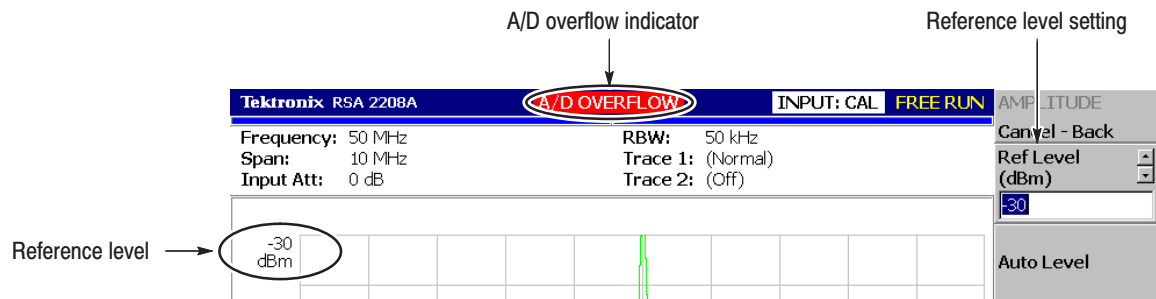

Figure 4-3: Reference level setting and A/D overflow indicator

8. Check the spectrogram display:

- a. Press the **S/A** key on the front panel.
- b. Press the **S/A with Spectrogram** side key. Check that the spectrogram is displayed on the lower side of the screen (see Figure 4-4).

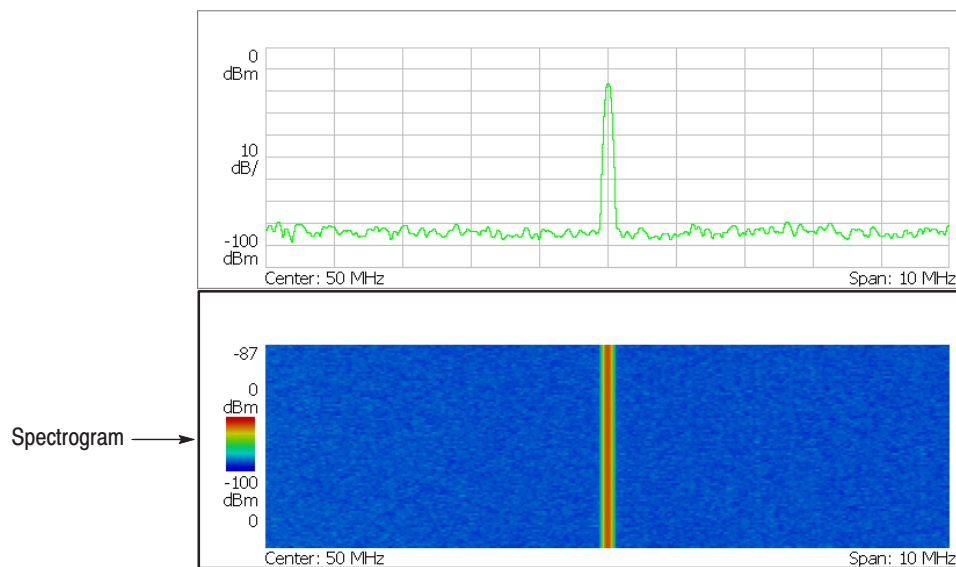

Figure 4-4: Spectrogram display

- c. Press the **RUN/STOP** key on the front panel to stop data acquisition. Confirm that the trace display freezes and **PAUSE** is displayed in the status indicator at the top right of the screen.

Diagnostics

You can run the internal diagnostic program to check hardware states. Table 4–2 shows the test items and their descriptions.

Table 4-2: Internal diagnostic program

Menu item	Description	Possible failure
Temp Sensor	Checks that the temperature sensor works correctly.	RF5 module
Data Memory	Checks that the acquisition memory works correctly.	A41 board

Equipment Required	None
Prerequisites	Power on the analyzer and allow a 20 minute warm-up before doing this procedure.

1. Press **CAL** → **Service...** → **Password**.
2. Enter **270833** and then press the **ENTER** key using the numeric keypad.
3. Press the **DIAG** side key.
4. Select the diagnostic menu item to be executed.
You may press the **All** side key to run all the tests.
5. Check the result shown in the lower left view with “Pass” or “Fail”.

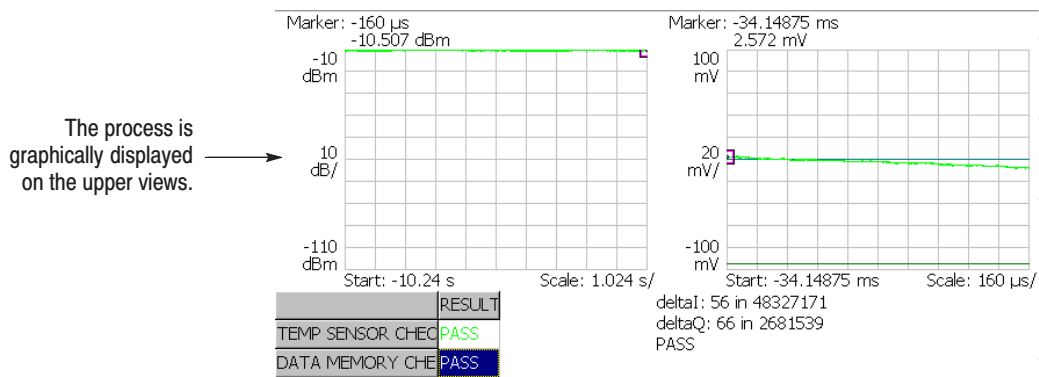

Figure 4-5: Diagnostic screen

Performance Tests

This section contains a collection of procedures for checking that the RSA2203A and RSA2208A Real-Time Spectrum Analyzers perform as warranted.

STOP. *These procedures extend the confidence level provided by the basic procedures described on page 4–3. Perform the basic procedures first and then perform the following procedures if desired.*

There are two types of performance tests: *Auto Tests* and *Manual Tests*.

- *Auto Tests* use internal routines to verify that the analyzer functions properly and was adjusted properly.
- *Manual Tests* supplement the Auto Tests to verify the analyzer performance formally and report the test records.

Prerequisites

The tests in this section comprise an extensive, valid confirmation of performance and functionality when the following requirements are met:

- The cabinet must be installed on the analyzer.
- The instrument must have passed the procedures under *Brief Procedures* found on page 4–3.
- A signal-path compensation must have been done within the recommended calibration interval and at a temperature within ± 3 °C of the present operating temperature. (If at the time you did the prerequisite *Brief Procedures*, the temperature was within the limits just stated, consider this prerequisite met.)
- The analyzer must have been last adjusted at an ambient temperature between +20 °C and +30 °C, must have been operating for a warm-up period of at least 20 minutes, and must be operating at an ambient temperature of between +10 °C and +40 °C. (The warm-up requirement is usually met in the course of meeting the Brief Procedures prerequisites listed above.)
- The SG flatness floppy disks must be prepared (Item 18 in Table 4–3). For the procedure to create or update the flatness correction files, refer to *Making Flatness Correction Files* on page 5–5.

Equipment Required

These procedures use external, traceable signal sources to directly check warranted characteristics. The required equipment list follows this introduction.

Table 4–3: Test equipment

Item number and description	Minimum requirements	Example	Purpose
1. Signal generator ¹	Frequency range : 10 kHz to 3.5 GHz; Variable amplitude from -70 dBm to +13 dBm into 50 Ω ; Accuracy: $<\pm 1$ dB; Function: FM	Agilent 8648D	Checking baseband and RF flatness
2. Signal generator	Frequency range: 10 MHz to 8 GHz; Output level: -4 dBm to +10 dBm; Accuracy: $<\pm 1$ dB	Agilent 83712B	Checking RF flatness for RSA2208A only

¹ For RSA2203A, you can use the signal generator with the frequency range of 10 kHz to 3 GHz, for example Agilent 8648C.

Table 4-3: Test equipment (Cont.)

Item number and description	Minimum requirements	Example	Purpose
3. Signal generator	Output: ≥ -10 dBm at 25 MHz; SSB phase noise: < -110 dBc/Hz at 10 kHz offset	Anritsu MG3642A	Checking amplitude accuracy
4. Signal generator	Frequency: 2GHz; Output: ≥ -10 dBm; Digital modulation: QPSK; Symbol rate: 4.096 M/s	Rohde & Schwartz SMIQ03B	Checking intermodulation distortion
5. Frequency counter	Frequency range: 10 MHz; Aging rate: $< 5 \times 10^{-10}$ /day; Accuracy: < 0.01 ppm at 10 MHz	Agilent 53132A option 010	Checking the reference output frequency accuracy
6. RF power meter	1 MHz to 8 GHz	Agilent E4418B	Adjusting the signal generator output level
7. RF power sensor	10 MHz to 8 GHz; RF Flatness: < 3 %; Uncertainty of calibration factor data: < 2 % (RSS)	Agilent E4412A	Adjusting the signal generator output level
8. Power combiner	Range: 500 MHz to 2 GHz; Isolation: > 18 dB; Insertion loss: < 1.0 dB	Mini-Circuits ZAPD-21	Checking intermodulation distortion
9. Channel filter	Center frequency: 2.1425 GHz; Bandwidth: 4.1 MHz	K & L WSF-00129	Checking intermodulation distortion
10. BNC cable	50 Ω , 36 in, male to male BNC connectors	Tektronix part number 012-1341-00	Signal interconnection
11. N-N cable	50 Ω , 36 in, male to male N connectors		Signal interconnection
12. N-SMA cable (Three required)	50 Ω , 36 in, male N to male SMA connectors		Signal interconnection
13. GPIB cable (Two required for RSA2208A)	2m, double-shielded	Tektronix part number 012-0991-00	Software-based tests
14. Terminator	Impedance: 50 Ω ; connectors: female BNC input, male BNC output	Tektronix part number 011-0049-01	Signal termination for checking frequency accuracy
15. RF attenuator	Ratio: 10 dB; impedance 50 Ω ; Bandwidth: > 8 GHz	Inmet 18N-10 Mini-Circuits BW-S10W2	Checking flatness
16. Mouse	USB	Optional accessory	File operation
17. Keyboard	USB	Optional accessory	File operation
18. SG flatness floppy disk (Two required for RSA2208A)	Created or updated with the procedures described on page 5-5	3.5 inch, 720 K or 1.44 MB, DOS-compatible floppy disk	Storing flatness correction data for the signal generators (Item 1 and 2)

Auto Tests

The auto tests include the following items:

- Baseband flatness test
- IF flatness test
- RF flatness test
- Spurious test

Equipment Required	One signal generator (Item 1) One signal generator (Item 2, for RSA2208A only) One 50 Ω N-N coaxial cable (Item 11) One 10 dB attenuator (Item 15) One GPIB cable (Item 13, two required for RSA2208A) One mouse (Item 16) One keyboard (Item 17) One SG flatness floppy disk (Item 18, two required for RSA2208A)
Prerequisites	Refer to page 4-10

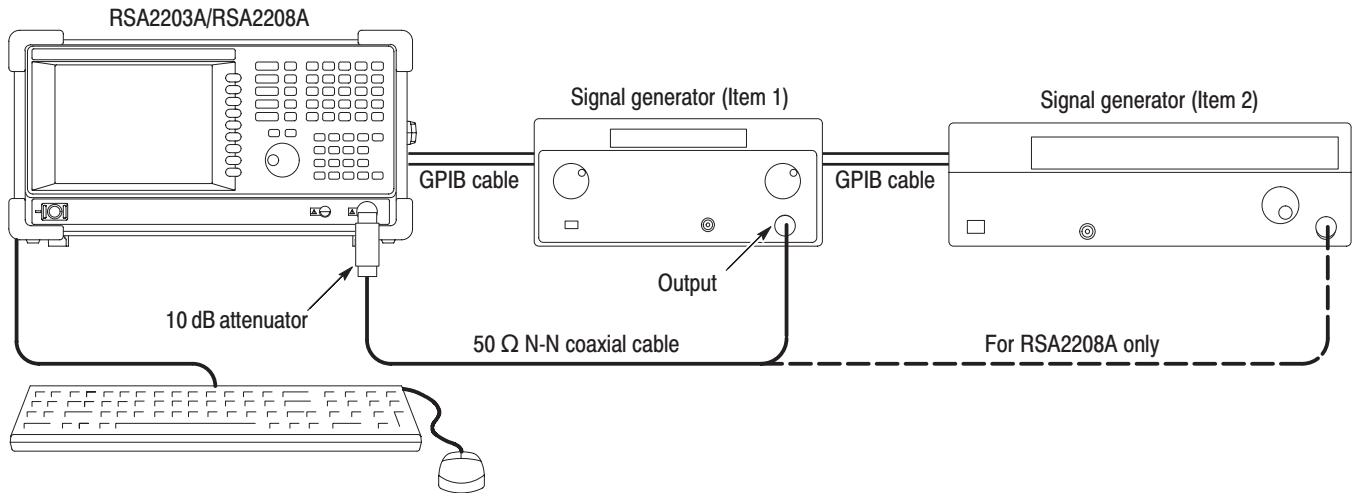

Figure 4-6: Initial test hookup

1. *Prepare for the test:*
 - a. Turn off the RSA2203A/RSA2208A analyzer and the signal generators.
 - b. Connect the analyzer and the generator(s) with GPIB cable(s). See Figure 4–6.
 - c. Connect the analyzer **INPUT** through a 10 dB attenuator followed by a 50 Ω N-N coaxial cable to the generator (Item 1) output.
 - d. Connect a mouse and a keyboard (Items 16 and 17) to the USB connectors of the analyzer.
 - e. Power on the analyzer and the generator(s).
 - f. Set the GPIB address of the generator(s), ranging from 1 to 30. If you use two generators, assign a unique address to each instrument.
 - g. Insert the SG flatness floppy disk (Item 18) for the generator (Item 1) to the floppy disk drive of the analyzer.
 - h. *Initialize the analyzer:*
 - Press the **SYSTEM** key on the front panel.
 - Press the **Reset All to Factory Defaults** side key.
2. *Perform the self calibration:*
 - a. Press the **CAL** key on the front panel.
 - b. Press the **Calibrate Gain** side key to execute the gain calibration and check that the calibration terminates normally.
 - c. Press the **Calibrate Center Offset** side key to execute the center offset calibration and check that the calibration terminates normally.

STOP. *Substeps d and e are for Option 05 (Baseband frequency extension) only. For the analyzer without Option 05, skip to step 3.*

- d. *Modify the analyzer controls:*
 - Press the **FREQUENCY/CHANNEL** key.
 - With the **Center Freq** side key, set the frequency to 10 MHz using the numeric keypad to operate the analyzer in the baseband.
- e. Press the **Calibrate DC Offset** side key to execute the DC offset calibration and check that the calibration terminates normally.

3. Enter the PV (Performance Verification) menu:
 - a. Press **CAL** → **Service...** → **Password**.
 - b. Input **270833** and then press **ENTER** using the numeric keypad.
 - c. Press the **PV** side key.

STOP. Step 4 is for Option 05 (Baseband frequency extension) only.
For the analyzer without Option 05, skip to step 5.

4. Check the baseband flatness:
 - a. Press the **BB Flatness PV** side key.
 - b. Set the GPIB address of the generator:
 - Press the **SG** side key to select the manufacturer of the generator for the GPIB command system: HP or Anritsu.

NOTE. The HP setting also supports Agilent and Rohde & Shwartz products.

- Press the **GPIB Address** side key and set the generator address.
- c. Press the **Measurement** side key.

A file selection box appears (the default directory is *My Documents*).
 - d. Enter a file name, for example *BBFlatness.pv*, using the keyboard.
(If necessary, change the directory.)
 - e. Click the **Open** button with the mouse.

The test starts. The result is written in text format to the specified file.
 - f. Check against limits:
 - Select the upper left view with the VIEW: **SELECT** key.
 - Press the VIEW: **SCALE** key.
 - Press the **Vertical Scale** side key and set the value to 1 dB.
 - Press the **Vertical Start** side key and set the value to -0.5 dBm.
 - Check that the difference between the maximum and the minimum values is within ± 0.5 dB.
 - g. Press the **Cancel-Back** side key twice to return to the PV menu.

5. Check the *IF flatness* in the *RF (RSA2203A) / RF1 (RSA2208A)* band:
 - a. Press the **IF Flatness PV** side key.
 - b. Set the *GPIB address of the generator*:
 - Press the **SG** side key to select the manufacturer of the generator: HP or Anritsu.

NOTE. The *HP* setting also supports *Agilent* and *Rohde & Shwartz* products.

- Press the **GPIB Address** side key and set the generator address.
- c. Press the **Measurement** side key.

A file selection box appears (the default directory is *My Documents*).
 - d. Enter a file name, for example *IF1Flatness.pv*, using the keyboard. (If necessary, change the directory.)
 - e. Click the **Open** button with the mouse.

The test starts. The result is written in text format to the specified file.
 - f. After the test is completed, check that flatness is sufficiently achieved in the upper left view.
6. Check the *RF flatness* in the *RF (RSA2203A) / RF1 (RSA2208A)* band:
 - a. Press the side key **Cancel-Back** → **RF Flatness PV**.
 - b. Set the *GPIB address of the generator*:
 - Press the **SG** side key to select the manufacturer of the generator: HP or Anritsu.
 - Press the **GPIB Address** side key and set the generator address.
 - c. Press the **Measurement** side key.

A file selection box appears (the default directory is *My Documents*).
 - d. Enter a file name, for example *RF1Flatness.pv*, using the keyboard. (If necessary, change the directory.)
 - e. Click the **Open** button with the mouse.

The test starts. The result is written in text format to the specified file.

f. *Check against limits:*

- Select the upper left view with the VIEW: **SELECT** key.
- Press the VIEW: **SCALE** key.
- Press the **Vertical Scale** side key and set the value to 2.4 dB.
- Press the **Vertical Start** side key and set the value to -1.2 dBm.
- Check that the difference between the maximum and the minimum values is within ± 1.2 dB.

STOP. Steps 7 through 9 are the tests in the RF2 and RF3 bands for RSA2208A only. For RSA2203A, skip to step 10.

7. *Change the signal generator:*

- a.** Disconnect the N-N cable from the signal generator (Item 1) output.
- b.** Connect the N-N cable to the signal generator (Item 2) output. See Figure 4-6 on page 4-12 again.
- c.** *Replace the SG flatness floppy disk:*
 - Eject the SG flatness floppy disk from the disk drive of the analyzer.
 - Insert the SG flatness floppy disk for the signal generator (Item 2).

8. *Check the IF flatness in the RF2 and RF3 bands for RSA2208A:*

- a.** Press the side key **Cancel-Back** (twice) → **IF Flatness PV**.
- b.** *Set the GPIB address of the generator:*
 - Press the **SG** side key to select the manufacturer of the generator: HP or Anritsu.
 - Press the **GPIB Address** side key and set the generator address.
- c.** Press the **Band** side key to select the frequency band (RF2 first).
- d.** Press the **Measurement** side key.

A file selection box appears (the default directory is *My Documents*).

- e.** Enter a file name, for example *IF2Flatness.pv*, using the keyboard. (If necessary, change the directory.)
- f.** Click the **Open** button with the mouse.

The test starts. The result is written in text format to the specified file.

11. *Check spurious response in the RF (RSA2203A) / RF1 (RSA2208A) band:*

- a. Press the side key **Cancel-Back** → **Spurious PV**.
- b. *Modify the analyzer settings:*
 - Press the **SG** side key to select the manufacturer of the generator: HP or Anritsu.
 - Press the **GPIB Address** side key and set the generator address.
 - Press the **Threshold** side key and set the value to -73 dBc.
- c. Make sure that Band (the top side key) is set to RF1.
- d. Press the **Measurement** side key.

A file selection box appears (the default directory is *My Documents*).
- e. Enter a file name, for example *SyntheTable1.pv*, using the keyboard. (If necessary, change the directory.)
- f. Click the **Open** button with the mouse.

The test starts. If spurious occurred, the frequency is written in text format to the specified file.

STOP. *Substep 12 and 13 are the tests in the RF2 and RF3 bands for RSA2208A only. For RSA2203A, skip to step 14.*

12. *Modify the hookup:*

- a. Disconnect the N–N cable from the signal generator (Item 1) output.
- b. Connect the N–N cable to the signal generator (Item 2) output. See Figure 4–6 on page 4–12.

13. *Check spurious response in the RF2 and RF3 bands for RSA2208A:*

- a. *Modify the analyzer settings:*
 - Press the **SG** side key to select the manufacturer of the generator: HP or Anritsu.
 - Press the **GPIB Address** side key and set the generator address.
 - Press the **Threshold** side key and set the value to -70 dBc.
- b. Press the **Band** side key to select the frequency band (RF2 first).

- c. Press the **Measurement** side key.

A file selection box appears (the default directory is *My Documents*).

- d. Enter a file name, for example *SyntheTable2.pv*, using the keyboard. (If necessary, change the directory.)

- e. Click the **Open** button with the mouse.

The test starts. If spurious occurred, the frequency is written in text format to the specified file.

- f. Repeat substeps b to e for the RF3 band.

14. *Check the log files:* Check the file contents using a word processor such as Notepad on the Windows desktop with the mouse and the keyboard.

15. *Disconnect the hookup:*

- a. Disconnect the N–N cable at the generator output and the analyzer input.
- b. Turn off the analyzer and the generator(s).
- c. Disconnect the GPIB cables from all the ports.

Manual Tests

The manual tests include the following items:

- 10 MHz reference output
- Absolute amplitude accuracy
- Input attenuator setting uncertainty
- Spectrum purity
- 3rd order intermodulation distortion
- Frequency readout accuracy
- Spurious response
- Displayed average noise level
- Residual response

10 MHz Reference Output Test

This procedure checks that the output frequency from the **REF OUT** connector (on the rear panel) is within the specified range for the analyzer.

Equipment Required	One frequency counter (Item 5) One 50 Ω BNC coaxial cable (Item 10) One 50 Ω terminator (Item 14)
Prerequisites	Refer to page 4–10. The frequency counter must have been operating for a warm-up period of at least 24 hours.

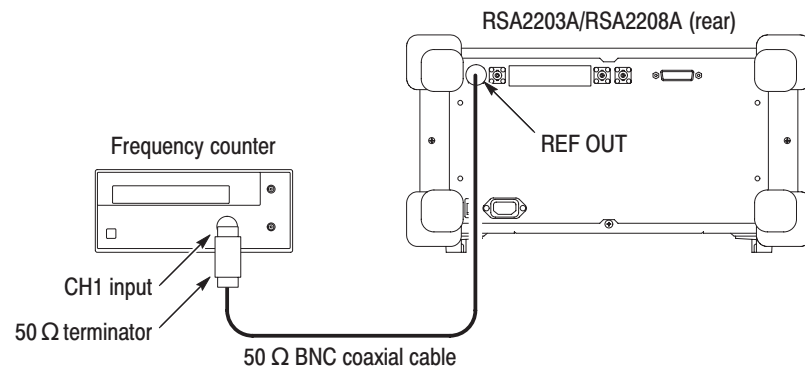

Figure 4–7: Initial test hookup

1. *Prepare for the test:*
 - a. *Hook up the frequency counter:* Connect **REF OUT** on the rear panel of the analyzer through a 50 Ω precision coaxial cable and a 50 Ω precision terminator to Channel 1 of the counter. See Figure 4–7.
 - b. *Set the counter controls:*

```

Function ..... Frequency 1
Gate time ..... 2 s

```
2. *Check the frequency:* Check that the frequency counter reads 10 MHz \pm 1.2 Hz.
3. *Disconnect the hookup:* Disconnect the cable at **REF OUT**.

Absolute Amplitude Accuracy Test

Check that the absolute amplitude error is within the specified range for the analyzer. It uses a power meter and a power sensor to set the signal generator output accurately.

Equipment Required	One signal generator (Item 1) One power meter (Item 6) One power sensor (Item 7) One 50 Ω N-N coaxial cables (Item 11)
Prerequisites	Refer to page 4-10.

1. Set up the power meter and sensor:

NOTE. Store the power sensor correction factors in the power meter, if you have not yet done so. When you use the Agilent 437B power meter, refer to Storing Calibration Factors in the Power Meter on page 5-3.

- a. Connect the power meter and the power sensor. See Figure 4-8 below.

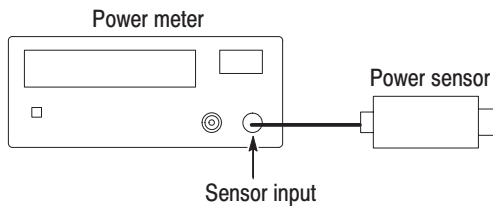

Figure 4-8: Initial hookup for setting up the power meter and sensor

- b. Warm up the power meter and sensor for more than 20 minutes.
- c. Press **ZERO** on the power meter.
- d. Connect the RF input of the power sensor to the power reference output of the power meter. See Figure 4-9 on page 4-23.
- e. Turn on **POWER REF** and execute the calibration.
- f. Disconnect the RF input of the power sensor from the reference output of the power meter.

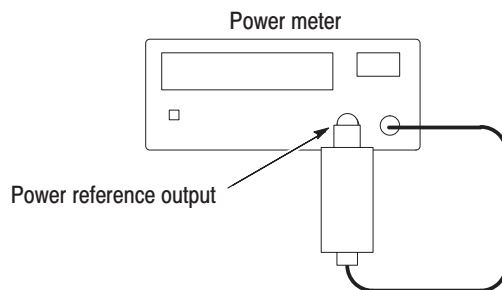

Figure 4-9: Hookup for calibrating the power sensor

STOP. Steps 2 through 5 are for Option 05 (Baseband frequency extension) only. For the analyzer without Option 05, skip to step 6.

Baseband (Option 05 Only).

2. Set the signal generator output:

- a. *Hook up the instruments:* Connect the signal generator (Item 1) output through a 50 Ω N-N coaxial cable to the power sensor input. See Figure 4-10.

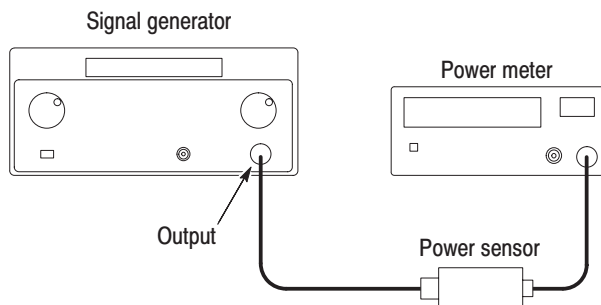

Figure 4-10: Hookup for setting the signal generator output

b. Set the signal generator controls:

Frequency 10 MHz
Level -10 dBm

c. Set the power meter control:

Frequency 10 MHz

RF (RSA2203A) / RF1 (RSA2208A).

6. *Modify the signal generator output:*
 - a. *Hook up the test equipment:* Connect the signal generator output through a 50 Ω N-N coaxial cable to the power sensor input. See Figure 4–10 on page 4–23.
 - b. *Modify the signal generator controls:*
 - Frequency 50 MHz
 - Level –20 dBm
 - c. *Modify the power meter control:*
 - Frequency 50 MHz
 - d. Adjust the output level of the signal generator so that the power meter reads –20 dBm \pm 0.05 dBm.
 - e. Disconnect the cable from the power sensor input.
7. *Modify the test hookup and preset the instrument controls:*
 - a. *Hook up the instruments:* Connect the signal generator output through a 50 Ω N-N coaxial cable to the RSA2203A/RSA2208A **INPUT**. See Figure 4–11 on page 4–24.
 - b. *Initialize the analyzer:*
Press **SYSTEM** \rightarrow **Reset All to Factory Defaults**.
 - c. *Calibrate the analyzer gain:* Press **CAL** \rightarrow **Calibrate Gain**.
 - d. *Modify the analyzer controls:*
 - Press the **FREQUENCY/CHANNEL** key on the front panel.
 - With the **Center Freq** side key, set the frequency to 50 MHz using the numeric keypad.
 - Press the **AMPLITUDE** key on the front panel.
 - Press the **RF Atten/Mixer** side key to select RF Att.
 - With the **RF Att** side key, set the attenuation to 0 dB.
8. *Check the amplitude:*
 - a. Press the **PEAK** key on the front panel to place the marker on the peak.
 - b. Check that the marker readout is within –20 dBm \pm 0.5 dB.
9. *Disconnect the test equipment:* Disconnect the cable at the analyzer input.

**Input Attenuator Setting
Uncertainty Test**

Check the input attenuator setting error is within the specified range for the analyzer.

Equipment Required	One signal generator (Item 1) One 50 Ω N-N coaxial cables (Item 11)
Prerequisites	Refer to page 4-10.

1. *Prepare for the test:*

a. *Set the generator controls:*

Frequency 50 MHz
 Amplitude -25 dBm
 RF output On

b. *Hook up the generator:* Connect the generator output through a 50 Ω N-N coaxial cable to the analyzer **INPUT**. See Figure 4-12.

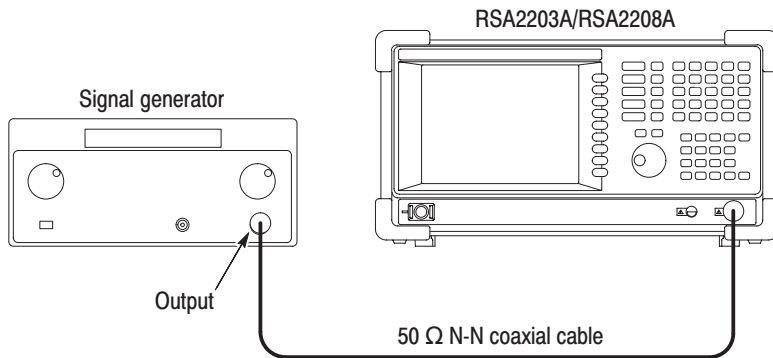

Figure 4-12: Initial test hookup

c. *Initialize the analyzer:*

- Press the **SYSTEM** key on the front panel.
- Press the **Reset All to Factory Defaults** side key.

- d. *Modify the default settings:*
 - Press the **FREQUENCY/CHANNEL** key on the front panel.
 - With the **Center Freq** side key, set the frequency to 50 MHz using the numeric keypad.
 - Press the **AMPLITUDE** key on the front panel.
 - With the **Ref Level** side key, set the reference level to -20 dBm using the general purpose knob.
 - Press the **RF Atten/Mixer** side key to select **RF Att**.
 - With the **RF Att** side key, set the attenuation to 0 dB using the numeric keypad or the general purpose knob.
2. *Measure the reference amplitude at 0 dB attenuation:*
 - a. Press the **PEAK** key on the front panel to place the marker on the peak.
 - b. Record the peak amplitude at the marker readout as the reference value. (Let the value be P_0 .)
3. *Check the amplitude for the attenuation from 2 to 30 dB:*
 - a. Press the **RF Att** side key and set the attenuation (initially 2 dB).
 - b. Press the **PEAK** key on the front panel to place the marker on the peak.
 - c. Record the peak amplitude at the marker readout. (Let the value be P_X .)
 - d. Check that the error ($P_X - P_0$) is within ± 0.5 dB.
 - e. Repeat substeps a through d for attenuation from 2 to 30 dB in 2 dB steps.
4. *Modify the generator controls:*

Amplitude -5 dBm
5. *Modify the analyzer controls:*
 - a. Press the **AMPLITUDE** key on the front panel.
 - b. With the **Ref Level** side key, set the reference level to 0 dBm using the general purpose knob.
 - c. Make sure that RF Att is set to 30 dB.

6. *Measure the reference amplitude at 30 dB attenuation:*
 - a. Press the **PEAK** key on the front panel to place the marker on the peak.
 - b. Record the peak amplitude at the marker readout as the reference value. (Let the value be P_1 .)
7. *Check the amplitude for attenuation from 32 to 50 dB:*
 - a. Press the **RF Att** side key and set the attenuation (initially 32 dB).
 - b. Press the **PEAK** key on the front panel to place the marker on the peak.
 - c. Record the peak amplitude at the marker readout. (Let the value be P_X .)
 - d. Check that the error ($P_X - P_1$) is within ± 0.5 dB.
 - e. Repeat substeps a through d for attenuation from 32 to 50 dB in 2 dB steps.
8. *Disconnect the test equipment:* Disconnect the cable at the analyzer input.

Spectrum Purity Test

Check that the Carrier-to-Noise (C/No) is within the specified range for the analyzer.

Equipment Required	One signal generator (Item 4) One 50 Ω N-N coaxial cable (Item 11)
Prerequisites	Refer to page 4-10.

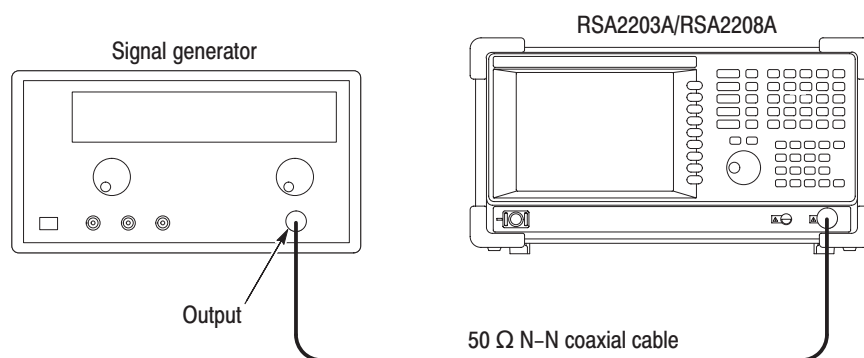

Figure 4-13: Initial test hookup

1. Prepare for the test:

a. Initialize the analyzer:

- Press the **SYSTEM** key on the front panel.
- Press the **Reset All to Factory Defaults** side key.

b. Modify the default settings:

- Press the **AMPLITUDE** key on the front panel.
- Press the **RF Atten/Mixer** side key to select Mixer.
- With the **Mixer Level** side key, set the level to -15 dBm.
- Press the **TRACE/AVG** key.
- Press the side key **Trace 1 Type... → Average**.
- Press the **Number Of Averages** side key and set the value to 50 using the general purpose knob.

- c. *Set the generator controls:*
 - Frequency 1500 MHz
 - Amplitude -5 dBm
 - RF output On
 - d. *Hook up the signal generator:* Connect the generator output through a 50 Ω N-N coaxial cable to the analyzer **INPUT**. See Figure 4–13.
2. *Check phase noise for a span of 100 kHz:*
- a. *Modify the analyzer controls:*
 - Press the **SPAN** key on the front panel.
 - With the **Span** side key, set the span to 100 kHz using the general purpose knob or the numeric keypad.
 - Press the **RBW/FFT** key on the front panel.
 - Press the **RBW/FFT** side key to select **Man**.
 - With the **RBW** side key, set the RBW to 200 Hz.
 - b. *Perform the C/N measurement:*
 - Press the key **MEASURE** → **C/N** → **MEAS SETUP**.
 - Press the **Offset Frequency** side key and set the value to 10 kHz using the general purpose knob.
 - Press the **Noise Bandwidth** side key and set the value to 2 kHz using the general purpose knob.
 - c. *Check against limits:* Read the phase noise (C/No) at the bottom of the screen. Confirm that the value is 100 dB/Hz or more.
3. *Check phase noise for a span of 1 MHz:*
- a. *Modify the analyzer controls:*
 - Press the **SPAN** key on the front panel.
 - With the **Span** side key, set the span to 1 MHz using the general purpose knob or the numeric keypad.
 - Press the **RBW/FFT** key on the front panel.
 - Press the **RBW/FFT** side key to select **Man**.
 - With the **RBW** side key, set the RBW to 2 kHz.

3rd Order Intermodulation Distortion Test

Check that the 3rd order intermodulation distortion is within the specified range for the analyzer.

Equipment Required	Two signal generators (Items 2 and 4) One power combiner (Item 8) One channel filter (Item 9) One 50 Ω N-N coaxial cable (Item 11) Three 50 Ω N-SMA coaxial cables (Item 12)
Prerequisites	Refer to page 4-10.

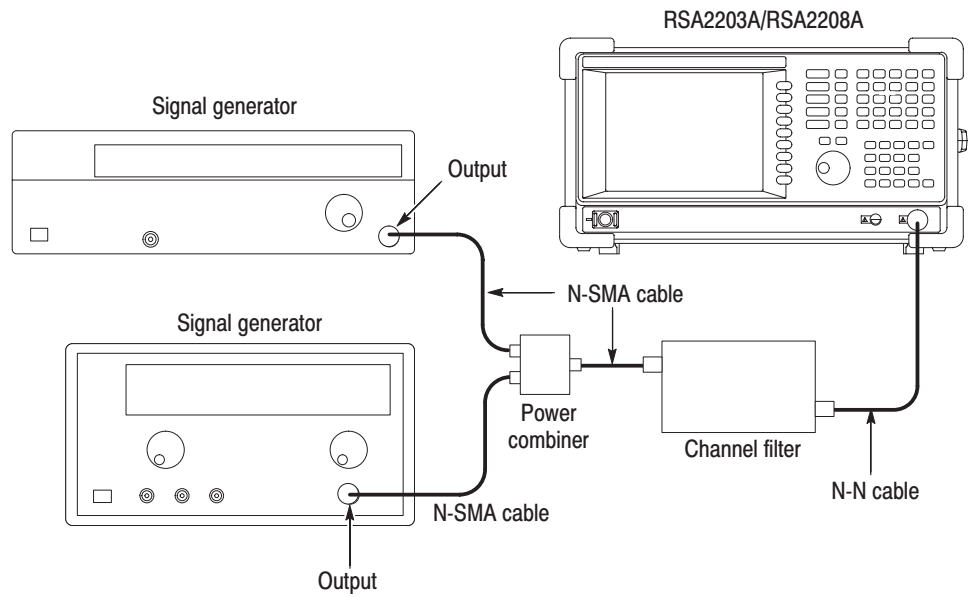

Figure 4-14: Initial test hookup

1. *Prepare for the test:*
 - a. Connect each generator output through a 50 Ω N-SMA coaxial cable to each power combiner input. See Figure 4–14.
 - b. Connect the power combiner output through a 50 Ω N-SMA coaxial cable to the channel filter input.
 - c. Connect the channel filter output through a 50 Ω N-N coaxial cable to the analyzer **INPUT**.
 - d. *Set the signal generator (Item 2) controls:*
 - Frequency 2.141 GHz
 - Level 0 dBm
 - e. *Set the signal generator (Item 4) controls:*
 - Frequency 2.144 GHz
 - Level 0 dBm
 - f. *Initialize the analyzer:*
 - Press the **SYSTEM** key on the front panel.
 - Press the **Reset All to Factory Defaults** side key.
 - g. *Modify the default controls:*
 - Press the **FREQUENCY/CHANNEL** key on the front panel.
 - With the **Center Freq** side key, set the frequency to 2.1425 GHz using the numeric keypad.
 - Press the **AMPLITUDE** key on the front panel.
 - With the **Ref Level** side key, set the level to 5 dBm using the general purpose knob.
 - Press the **RF Atten/Mixer** side key to select Rf Att.
 - With the **RF Att** side key, set the attenuation to 20 dB using the general purpose knob.
 - Press the **RBW/FFT** key on the front panel.
 - Press the **RBW/FFT** side key to select **Man**.
 - Press the **Extended Resolution** side key to select On.
 - With the **RBW** side key, set the RBW to 10 kHz.

Frequency Readout Test

Check that the frequency readout accuracy is within the specified range for the analyzer at 10 MHz (Option 05 only), 2 GHz, 5 GHz, and 7 GHz.

Equipment Required	One signal generator (Item 2) One 50 Ω N-N coaxial cable (Item 11)
Prerequisites	Refer to page 4-10.

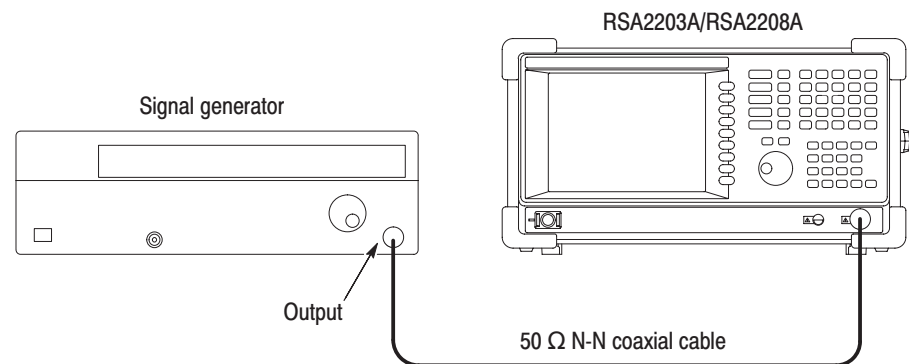

Figure 4-15: Initial test hookup

1. Prepare for the test:

a. Initialize the analyzer:

- Press the **SYSTEM** key on the front panel.
- Press the **Reset All to Factory Defaults** side key.

b. Set the generator controls:

Frequency 10 MHz
Level -10 dBm

c. Hook up the signal generator: Connect the generator output through a 50 Ω N-N coaxial cable to the analyzer **INPUT**. See Figure 4-15.

2. *Check frequency accuracy in the baseband (Option 05 only):*

a. *Modify the analyzer default settings:*

- Press the **FREQUENCY/CHANNEL** key on the front panel.
- With the **Center Freq** side key, set the frequency to 10 MHz using the numeric keypad.
- Press the **SPAN** key on the front panel.
- With the **Span** side key, set the span to 1 MHz using the general purpose knob.

b. *Measure peak frequency:*

- Press the **PEAK** key to place the marker on the peak signal.
- Read the marker readout. Confirm that the value is 10 MHz \pm 1 kHz.
- Press **MEASURE** \rightarrow **Carrier Frequency**.
- Read the measurement result at the bottom of the screen. Confirm that the value is 10 MHz \pm 50 Hz (without Option 10) / \pm 1.2 Hz (with Option 10).

3. *Check frequency accuracy in the RF (RSA2203A) /RF1 (RSA2208A) band:*

a. *Modify the generator control:*

Frequency 2 GHz

b. *Modify the analyzer controls:*

- Press the **FREQUENCY/CHANNEL** key on the front panel.
- With the **Center Freq** side key, set the frequency to 2 GHz using the numeric keypad.
- Press the **SPAN** key on the front panel.
- With the **Span** side key, set the span to 1 MHz using the general purpose knob.

c. *Measure peak frequency:*

- Press the **PEAK** key to place the marker on the peak signal.
- Read the marker readout. Confirm that the value is 2 GHz \pm 5 kHz (without Option 10) / \pm 1.2 kHz (with Option 10).
- Press **MEASURE** → **Carrier Frequency**.
- Read the measurement result at the bottom of the screen. Confirm that the value is 2 GHz \pm 4 kHz (without Option 10) / \pm 210 Hz (with Option 10).

STOP. Steps 4 and 5 are the tests in the RF2 and RF3 bands for RSA2208A only. For RSA2203A, skip to step 6.

4. *Check frequency accuracy in the RF2 band for RSA2208A:*

a. *Modify the generator control:*

Frequency 5 GHz

b. *Modify the analyzer controls:*

- Press the **FREQUENCY/CHANNEL** key on the front panel.
- With the **Center Freq** side key, set the frequency to 5 GHz using the numeric keypad.

c. *Measure peak frequency:*

- Press the **PEAK** key to place the marker on the peak signal.
- Read the marker readout. Confirm that the value is 5 GHz \pm 11 kHz (without Option 10) / \pm 1.5 kHz (with Option 10).
- Press **MEASURE** → **Carrier Frequency**.
- Read the measurement result at the bottom of the screen. Confirm that the value is 5 GHz \pm 10 kHz (without Option 10) / \pm 510 Hz (with Option 10).

5. *Check frequency accuracy in the RF3 band for RSA2208A:*

a. *Modify the generator control:*

Frequency 7 GHz

b. *Modify the analyzer controls:*

- Press the **FREQUENCY/CHANNEL** key on the front panel.
- With the **Center Freq** side key, set the frequency to 7 GHz using the numeric keypad.

c. *Measure peak frequency:*

- Press the **PEAK** key to place the marker on the peak signal.
- Read the marker readout. Confirm that the value is 7 GHz \pm 15 kHz (without Option 10) / \pm 1.7 kHz (with Option 10).
- Press **MEASURE** \rightarrow **Carrier Frequency**.
- Read the measurement result at the bottom of the screen. Confirm that the value is 7 GHz \pm 14 kHz (without Option 10) / \pm 710 Hz (with Option 10).

6. *Disconnect the test equipment:* Disconnect the cable at the analyzer input.

Spurious Response Test

Check that the spurious response is within the specified range for the analyzer.

Equipment Required	One signal generator (Item 2) One 50 Ω N-N coaxial cable (Item 11)
Prerequisites	Refer to page 4-10.

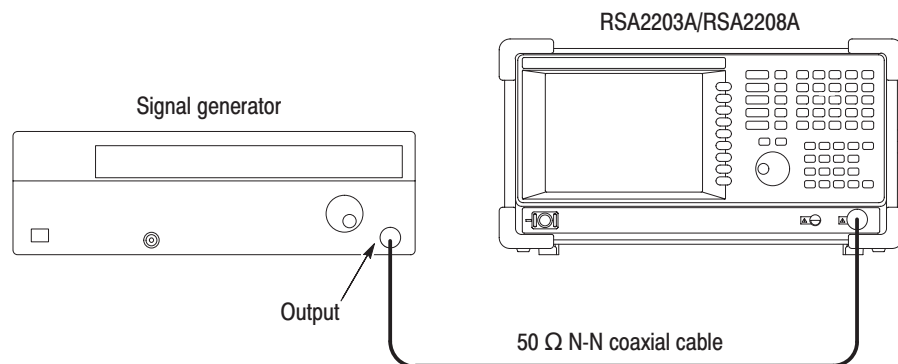

Figure 4-16: Initial test hookup

1. Prepare for the test:

a. Initialize the analyzer:

- Press the **SYSTEM** key on the front panel.
- Press the **Reset All to Factory Defaults** side key.

b. Modify the default controls:

- Press the **RBW/FFT** key on the front panel.
- Press the **RBW/FFT** side key to select **Man**.
- With the **RBW** side key, set the value to 50 kHz using the general purpose knob.
- Press the **TRACE/AVG** key on the front panel.
- Press the **Trace 1 Type...** side key and select **Average**.
- Press the **Number Of Averages** side key and set the value to 50.
- Press the **MARKER SETUP** key.
- Press the **Markers** side key to select Delta.

- c. *Set the generator controls:*
 - Level -5 dBm
 - d. *Hook up the signal generator:* Connect the generator output through a 50 Ω N-N coaxial cable to the analyzer **INPUT**. See Figure 4–16.
2. *Check spurious response:*
- a. *Modify the generator controls:* Set the generator output frequency to the value as shown in Table 4–4 (initially 10 MHz (with Option 05) / 2 GHz (without Option 05)).
 - b. *Modify the analyzer controls:*
 - Press the **FREQUENCY/CHANNEL** key on the front panel.
 - With the **Center Freq** side key, set the frequency to the same value as the generator output using the numeric keypad.
 - c. *Measure the amplitude:*
 - Press the **Select Marker** side key to select **1**.
 - Press the **PEAK** key and then the **MARKERS: ▼** (marker down) key once to place the first marker at the peak on the noise floor.
 - Press the **Select Marker** side key to select **2**.
 - Press the **PEAK** key to place Marker 2 on the peak signal.
 - Read the delta marker readout ($\Delta 1-2$) on the screen. Check that the components other than the carrier meet the requirement as shown in Table 4–4 (initially -73 dBc).
 - d. Repeat substeps a through c until all frequency settings listed in Table 4–4, are checked.

Table 4–4: Spurious measurement

Band	Frequency	Spurious response
Baseband (Option 05 only)	10 MHz	-73 dBc
RF (RSA2203A) / RF1 (RSA2208A)	2 GHz	-73 dBc
RF2 (RSA2208A only)	5 GHz	-70 dBc
RF3 (RSA2208A only)	7 GHz	-70 dBc

- 3. *Disconnect the test equipment:* Disconnect the cable at the analyzer input.

Displayed Average Noise Level Test

Check that the displayed average noise level is within the specified range for the analyzer.

Equipment Required	None
Prerequisites	Refer to page 4-10.

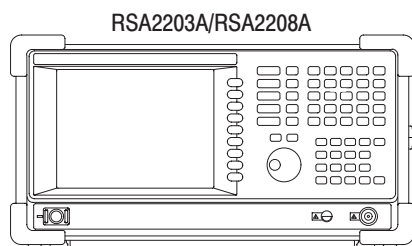

Figure 4-17: Initial test hookup

1. Prepare for the test:

a. Initialize the analyzer:

Press **SYSTEM** → **Reset All to Factory Defaults**.

b. Modify the analyzer controls:

- Press the **SPAN** key on the front panel.
- With the **Span** side key, set the span to 1 MHz using the general purpose knob.
- Press the **RBW/FFT** key on the front panel.
- Press the **RBW/FFT** side key to select **Man**.
- With the **RBW** side key, set the value to 10 kHz using the general purpose knob.
- Press the **TRACE/AVG** key on the front panel.
- Press the **Trace 1 Type...** side key and select **Average**.
- Press the **Number Of Averages** side key and set the value to 50.
- Press **MEASURE** → **Channel Power**.
- Press **MEAS SETUP** → **Channel Bandwidth** and set the value to 1 MHz using the general purpose knob.

2. *Check noise at 10 MHz in the baseband (Option 05 only):*
 - a. *Modify the analyzer control:*
 - Press the **FREQUENCY/CHANNEL** key on the front panel.
 - With the **Center Freq** side key, set the frequency to 10 MHz using the general purpose knob.
 - Press the **AMPLITUDE** key on the front panel.
 - With the **Ref Level** side key, set the level to –30 dBm using the general purpose knob.
 - b. *Check against limits:* Read the measurement result of Density at the bottom of the screen. Check that the value is –150 dBm/Hz or less.
3. *Check noise at 2 GHz in the RF (RSA2203A) / RF1 (RSA2208A) band:*
 - a. *Modify the analyzer control:*
 - Press the **FREQUENCY/CHANNEL** key on the front panel.
 - With the **Center Freq** side key, set the frequency to 2 GHz using the general purpose knob.
 - Press the **AMPLITUDE** key on the front panel.
 - With the **Ref Level** side key, set the level to –40 dBm using the general purpose knob.
 - Press the **RF Atten/Mixer** side key to select **RF Att**.
 - With the **RF Att** side key, set the attenuation to 0 dB using the general purpose knob.
 - b. *Check against limits:* Read the measurement result of Density at the bottom of the screen. Check that the value is –148 dBm/Hz or less.
4. *Check noise at 3 GHz in the RF (RSA2203A) / RF1 (RSA2208A) band:*
 - a. *Modify the analyzer control:*
 - Press the **FREQUENCY/CHANNEL** key on the front panel.
 - With the **Center Freq** side key, set the frequency to 3 GHz using the general purpose knob.
 - b. *Check against limits:* Read the measurement result of Density at the bottom of the screen. Check that the value is –147 dBm/Hz or less.

5. *Check noise at 7 GHz in the RF3 band for RSA2208A only:*
 - a. *Modify the analyzer control:*
 - Press the **FREQUENCY/CHANNEL** key on the front panel.
 - With the **Center Freq** side key, set the frequency to 7 GHz using the general purpose knob.
 - b. *Check against limits:* Read the measurement result of Density at the bottom of the screen. Check that the value is -141 dBm/Hz or less.

Residual Response Test Check that the residual noise level is within the specified range for the analyzer.

Equipment Required	None
Prerequisites	Refer to page 4–10.

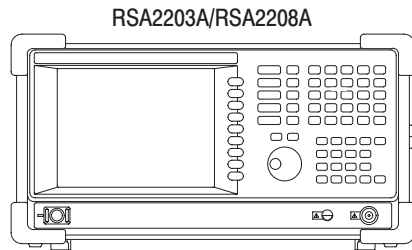

Figure 4–18: Initial test hookup

1. Prepare for the test:

a. Initialize the analyzer:

- Press the **SYSTEM** key on the front panel.
- Press the **Reset All to Factory Defaults** side key.

b. Modify the default settings:

- Press the **AMPLITUDE** key on the front panel.
- With the **Ref Level** side key, set the level to -30 dBm using the general purpose knob.
- Press the **RBW/FFT** key on the front panel.
- Press the **RBW/FFT** side key to select **Man**.
- With the **RBW** side key, set the RBW to 100 kHz using the general purpose knob.
- Press the **TRACE/AVG** key on the front panel.
- Press the **Trace 1 Type...** side key and select **Average**.
- Press the **Number Of Averages** side key and set the value to 50 using the general purpose knob.

2. *Check residual response in the baseband (Option 05 only):*
 - a. *Modify the analyzer controls:*
 - Press the **FREQUENCY/CHANNEL** key on the front panel.
 - With the **Center Freq** side key, set the frequency to 10 MHz using the general purpose knob.
 - Press the **SPAN** key on the front panel.
 - With the **Span** side key, set the span to 20 MHz using the general purpose knob.
 - b. *Measure residual response:*
 - Press the **LINES** key on the front panel.
 - Press the **Show Line** side key to select **Vertical**.
 - Press the **Number Of Line** key to select **1**.
 - With the **Line1** side key, set the value to 1 MHz using the numeric keypad.
 - Press the **Show Line** side key to select **Horizontal**.
 - Press the **Number Of Line** key to select **1**.
 - With the **Line1** side key, set the value to -93 dBm using the numeric keypad.
 - c. *Check against limits:* Confirm that the residual signal level is -93 dBm or less at 1 MHz or more.
3. *Check residual response in the RF band (up to 3 GHz):*
 - a. *Modify the analyzer controls:*
 - Press the **FREQUENCY/CHANNEL** key on the front panel.
 - With the **Center Freq** side key, set the frequency to 1.5 GHz using the numeric keypad.
 - Press the **SPAN** key on the front panel.
 - With the **Span** side key, set the span to 3 GHz using the numeric keypad.

- b. Measure residual response:*
 - Press the **LINES** key
 - Press the **Show Line** side key to select **Vertical**.
 - Press the **Number Of Line** key to select **1**.
 - Press the **Line1** side key and set the value to 100 MHz.
 - Press the **Show Line** side key to select **Horizontal**.
 - Press the **Number Of Line** key to select **1**.
 - Press the **Line1** side key and set the value to –90 dBm using the numeric keypad.
 - c. Check against limits:* Confirm that the residual signal level is –90 dBm or less at 100 MHz or more.
- 4. Check residual response in the RF1 band for RSA2208A only:**
 - a. Modify the analyzer controls:*
 - Press the **SPAN** key on the front panel.
 - With the **Stop Freq** side key, set the frequency to 3.5 GHz using the numeric keypad.
 - b. Measure residual response:* Press the **PEAK** key to place the marker at the peak on the noise floor.
 - c. Check against limits:* Read the marker readout. Confirm that the residual signal level is –90 dBm or less within the whole bandwidth.
- 5. Check residual response in the RF2 band for RSA2208A only:**
 - a. Modify the analyzer controls:*
 - Press the **FREQUENCY/CHANNEL** key on the front panel.
 - With the **Center Freq** side key, set the frequency to 5 GHz using the numeric keypad.
 - b. Measure residual response:* Press the **PEAK** key to place the marker at the peak on the noise floor.
 - c. Check against limits:* Read the marker readout. Confirm that the residual signal level is –85 dBm or less within the whole bandwidth.

6. *Check residual response in the RF3 band for RSA2208A only:*
 - a. *Modify the analyzer controls:*
 - Press the **FREQUENCY/CHANNEL** key on the front panel.
 - With the **Center Freq** side key, set the frequency to 7 GHz using the numeric keypad.
 - b. *Measure residual response:* Press the **PEAK** key to place the marker at the peak on the noise floor.
 - c. *Check against limits:* Read the marker readout. Confirm that the residual signal level is -85 dBm or less within the whole bandwidth.

Test Record

Photocopy the following test record pages and use them to record the performance test results for your analyzer.

RSA2203A/RSA2208A Test Record

Serial Number:

Certificate Number:

Calibration Date:

Technician:

10 MHz reference output test	Low limit	Test result	High limit
Accuracy	9,999,998.8 Hz		10,000,001.2 Hz

Absolute amplitude accuracy test

Frequency	Test level	Low limit	Test result	High limit
10 MHz (Option 05 only)	-10 dBm	-10.3 dBm		-9.7 dBm
50 MHz	-20 dBm	-20.5 dBm		-19.5 dBm

Input attenuator setting uncertainty test

Attenuation	Measurement (P_X)	Low limit	Test result ($P_X - P_{0/1}$)	High limit
0 dB	P_0 :	-	-	-
2 dB		-0.5 dB		+0.5 dB
4 dB		-0.5 dB		+0.5 dB
6 dB		-0.5 dB		+0.5 dB
8 dB		-0.5 dB		+0.5 dB
10 dB		-0.5 dB		+0.5 dB
12 dB		-0.5 dB		+0.5 dB
14 dB		-0.5 dB		+0.5 dB
16 dB		-0.5 dB		+0.5 dB
18 dB		-0.5 dB		+0.5 dB
20 dB		-0.5 dB		+0.5 dB
22 dB		-0.5 dB		+0.5 dB
24 dB		-0.5 dB		+0.5 dB
26 dB		-0.5 dB		+0.5 dB
28 dB		-0.5 dB		+0.5 dB
30 dB		-0.5 dB		+0.5 dB

Input attenuator setting uncertainty test (Cont.)				
30 dB	P ₁ :	-	-	-
32 dB		-0.5 dB		+0.5 dB
34 dB		-0.5 dB		+0.5 dB
36 dB		-0.5 dB		+0.5 dB
38 dB		-0.5 dB		+0.5 dB
40 dB		-0.5 dB		+0.5 dB
42 dB		-0.5 dB		+0.5 dB
44 dB		-0.5 dB		+0.5 dB
46 dB		-0.5 dB		+0.5 dB
48 dB		-0.5 dB		+0.5 dB
50 dB		-0.5 dB		+0.5 dB

Spectrum purity test				
Span	Offset	Low limit	Test result	High limit
100 kHz	10 kHz	100 dB/Hz		
1 MHz	100 kHz	105 dB/Hz		
5 MHz	1 MHz	125 dB/Hz		

3rd order intermodulation distortion test	Low limit	Test result	High limit
3 rd order intermodulation distortion +5 dBm reference level, 2 GHz center frequency			-73 dBc

Frequency readout test (without Option 10)				
Frequency	Measurement	Low limit	Test result	High limit
10 MHz (Option 05 only)	Marker	9,999 kHz		10,001 kHz
	Carrier frequency meas.	9,999,950 Hz		10,000,050 Hz
2 GHz	Marker	1,999,995 kHz		2,000,005 kHz
	Carrier frequency meas.	1,999,996 kHz		2,000,004 kHz
5 GHz	Marker	4,999,989 kHz		5,000,011 kHz
	Carrier frequency meas.	4,999,990 kHz		5,000,010 kHz
7 GHz	Marker	6,999,985 kHz		7,000,015 kHz
	Carrier frequency meas.	6,999,986 kHz		7,000,014 kHz

Frequency readout test (with Option 10)				
Frequency	Measurement	Low limit	Test result	High limit
10 MHz (Option 05 only)	Marker	9,999 kHz		10,001 kHz
	Carrier frequency meas.	9,999,998.8 Hz		10,000,001.2 Hz
2 GHz	Marker	1,999,998.8 kHz		2,000,001.2 kHz
	Carrier frequency meas.	1,999,999,790 Hz		2,000,000,210 Hz
5 GHz	Marker	4,999,998.5 kHz		5,000,001.5 kHz
	Carrier frequency meas.	4,999,999,490 Hz		5,000,000,510 Hz
7 GHz	Marker	6,999,998.3 kHz		7,000,001.7 kHz
	Carrier frequency meas.	6,999,999,290 Hz		7,000,000,710 Hz

Spurious response test				
Frequency	Low limit	Test result	High limit	
10 MHz (Option 05 only)			-73 dBc	
2 GHz			-73 dBc	
5 GHz (RSA2208A only)			-70 dBc	
7 GHz (RSA2208A only)			-70 dBc	

Displayed average noise level test

Frequency	Low limit	Test result	High limit
10 MHz (Option 05 only)			-150 dBm/Hz
2 GHz			-148 dBm/Hz
5 GHz (RSA2208A only)			-147 dBm/Hz
7 GHz (RSA2208A only)			-141 dBm/Hz

Residual response test

Band	Frequency range	Low limit	Test result	High limit
Baseband (Option 05 only)	1 to 20 MHz			-93 dBm
RF (RSA2203A only)	0.5 to 3 GHz			-90 dBm
RF1 (RSA2208A only)	0.5 to 3.5 GHz			-90 dBm
RF2 (RSA2208A only)	3.5 to 6.5 GHz			-85 dBm
RF3 (RSA2208A only)	5 to 8 GHz			-85 dBm

Adjustment Procedures

Adjustment Procedures

This section contains information needed to manually adjust the RSA2203A and RSA2208A Real-Time Spectrum Analyzers.

The section is divided into three subsections:

- General information about adjusting the analyzer
- A list of equipment required to perform the adjustments
- The procedures for adjusting the analyzer

Purpose This procedure returns the analyzer to conformance with its *Warranted Characteristics* as listed in Section 1, *Specification*. It can also be used to optimize the performance of the analyzer. For performance verification procedures, refer to Section 4, *Performance Verification*.

Adjustment Interval Generally, these adjustments should be done every 12 months.

Adjustment After Repair After the removal and replacement of a module due to electrical failure, perform the adjustment procedures in this section.

Requirements for Performance

Before doing the adjustments, note the following requirements.

Personnel This procedure is only to be performed by trained service technicians.

Warm-Up Period This analyzer requires a 20 minute warm-up time in a 20 °C to 30 °C environment before it is adjusted. Adjustments done before the operating temperature has stabilized may cause errors in performance.

Test Equipment Table 5–1 lists all test equipment required to adjust the analyzer.

Equipment Required

Table 5–1 lists the test equipment required to adjust the RSA2203A/RSA2208A analyzer.

Table 5-1: Test equipment

Item number and description	Minimum requirements	Example	Purpose
1. Signal generator ¹	Frequency range: 10 kHz to 3.5 GHz; Variable amplitude from -70 dBm to +13 dBm into 50 Ω ; Accuracy: $<\pm 1$ dB; Function: FM	Agilent 8648D	Adjusting baseband and RF flatness
2. Signal generator	Frequency range: 10 MHz to 8 GHz; Output level: -4 dBm to +10 dBm; Accuracy: $<\pm 1$ dB	Agilent 83712B	Adjusting RF flatness for RSA2208A
3. Frequency counter	Frequency range: 10 MHz; Aging rate: $<5 \times 10^{-10}$ /day; Accuracy: <0.01 ppm at 10 MHz	Agilent 53132A option 010	Checking the reference output frequency accuracy
4. RF power meter ³	1 MHz to 8 GHz	Agilent 437B ⁴ Agilent E4418B ⁴	Adjusting the signal generator output level
5. RF power sensor ³	10 MHz to 8 GHz; RF Flatness: $<3\%$; Uncertainty of calibration factor data: $<2\%$ (RSS)	Agilent 8481A Agilent E4412A	Adjusting the signal generator output level
6. BNC cable	50 Ω , 36 in, male to male BNC connectors	Tektronix part number 012-1341-00	Signal interconnection
7. N-N cable	50 Ω , 36 in, male to male N connectors		Signal interconnection
8. GPIB cable (three required)	2m, double-shielded	Tektronix part number 012-0991-00	Software-based tests
9. Terminator	Impedance: 50 Ω ; connectors: female BNC input, male BNC output	Tektronix part number 011-0049-01	Signal termination for checking frequency accuracy
10. RF attenuator	Ratio: 10 dB; impedance 50 Ω		Checking flatness
11. N adapter ³	Female to female N connectors		Signal interconnection
12. Mouse	USB	Optional accessory	File operation
13. Keyboard	USB	Optional accessory	File operation
14. SG flatness floppy disk (Two required for RSA2208A)	Created or updated with the procedures described on page 5-5	3.5 inch, 720 K or 1.44 MB, DOS-compatible floppy disk	Storing flatness correction data for the signal generators (Item 1 and 2)
15. Adjustment Tool			Manual adjustments

¹ For RSA2203A, you can use the signal generator with the frequency range of 10 kHz to 3 GHz, for example Agilent 8648C.

² Use this instrument only. The adjustment procedures specify that the analyzer controls this instrument over the GPIB.

³ Required only when creating a flatness correction files for the signal generators (Item 1 and 2).

⁴ To make an SG flatness floppy disk (Item 14), use Agilent 437B or compatible. If you use another instrument, for example Agilent E4418B, select HP437B for the GPIB command set. To select the programming language, refer to the User's Guide of the instrument.

Preparation

Do the following procedures before executing the auto calibration:

- Store calibration factors in the power meter
- Prepare the flatness correction file for the signal generators.

Storing Cal Factors in the Power Meter

If you use an Agilent 437B power meter to create flatness correction files for the signal generators (Item 1 and 2), you have to store the calibration factors for a power sensor in the power meter. There are two ways to store calibration factors:

- Storing calibration factors manually
- Storing calibration factors through the analyzer

For information on storing calibration factors manually in the power meter, refer to the power meter user's guide. When you store calibration factors through the analyzer, use the following procedure.

Equipment Required	One power meter (Item 4) One GPIB cable (Item 8) One 720 K or 1.44 Mbyte, 3.5 inch DOS-compatible disk, if you load calibration factors from a floppy disk.
---------------------------	--

1. Make a text file on PC with the following format for a power sensor:

```
# NO=(sensor ID number: 0 to 9)
# SENSOR=(type of the sensor)
# SERIAL=(serial number of the sensor)
# REFCF=(ref cal factor)
(frequency)=(cal factor)
...
```

Information about these items is on the surface of the power sensor, except the sensor ID number which you specify. Input the calibration factors for the test or adjustment frequency range.

An example is shown below (frequency range: 0.1 to 9 GHz).

```
# NO=2
# SENSOR=HP8485A
# SERIAL=3318A16046
# REFCF=99.0
0.1e9=99.1
2e9=98.1
4e9=97.1
6e9=96.5
7e9=96.2
8e9=96.0
9e9=95.8
```

Save the file with the extension of *.cal* (for example, *sensor2.cal*). You can load the file to the power meter using a floppy disk or through network.

2. *Install the hookup and preset the instrument controls:*
 - a. Turn off the power meter and the analyzer.
 - b. Connect the GPIB cables on the power meter and the analyzer rear panel.

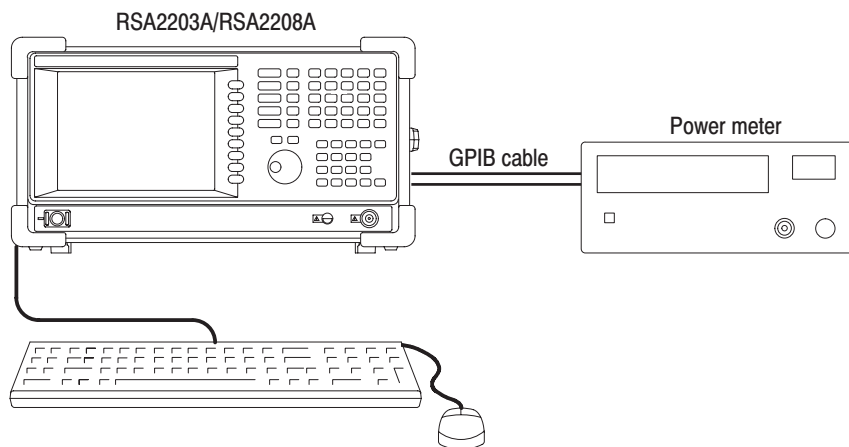

Figure 5-1: Hookup for storing the cal factors in the power meter

- c. Connect a mouse and a keyboard to the analyzer.
- d. Turn on the power meter and the analyzer.
- e. Set the GPIB address of the power meter to 13 (fixed).

3. *Store the calibration factors:*

- a. If you use a floppy disk, insert it to the disk drive on the analyzer.
- b. Press **CAL** → **Service...** → **Password**.
- c. Input **270833** and then press **ENTER** using the numeric keypad.
- d. Press the **CAL** side key.
- e. Press **MEASURE** → **SG Flatness**.
- f. Press the **Read Cal Factor** side key.

The file selection dialog box appears.

- g. Enter the file name and then press the **Open** button.

The calibration factors are stored in the power meter.

Making Flatness Correction Files

The auto performance verification and calibration need the flatness floppy disks for the signal generators (Item 1 and 2). The following procedures measure the flatness correction data for the specified signal generator and saves the data to a floppy disk.

You must create or update the flatness correction file when one of these conditions is met:

- When you calibrate the analyzer initially
- When you calibrate the signal generator
- When you change the signal generator
- When you change the N-N cable
- When you change the RF attenuator
- When one year has elapsed from the last update of the file for the generator

Equipment Required	One signal generator (Item 1 or 2) One power meter (Item 4) One power sensor (Item 5) One N-N cable (Item 7) Two GPIB cables (Item 8) One 10 dB attenuator (Item 10) One N adapter (Item 11) One floppy disk (Item 14)
Prerequisites	When using the power meter other than Agilent 437B, select HP437B for the GPIB command set. For selecting the programming language, refer to the operation manual of the instrument.

1. *Prepare for the adjustment:*

NOTE. *Store the power sensor correction factors in the power meter, if not yet. When you use the Agilent 437B power meter, refer to Storing Cal Factors in the Power Meter on page 5–3.*

- a. Turn off the signal generator, power meter, and analyzer.
- b. Connect the power sensor output to the power meter input.
See Figure 5–2.
- c. Connect the signal generator output through an 50 Ω N-N coaxial cable followed by a 10 dB attenuator and an N adapter to the power sensor input.
- d. Connect the GPIB cables on the signal generator, the power meter, and the analyzer rear panel.
- e. Turn on the signal generator, the power meter, and the analyzer.
- f. Set the GPIB address as follows:

Power meter	13 (fixed)
Signal generator	1 to 30 except 13
- g. *Initialize the analyzer:*
 - Press the **SYSTEM** key on the front panel.
 - Press the **Reset All to Factory Defaults** side key.

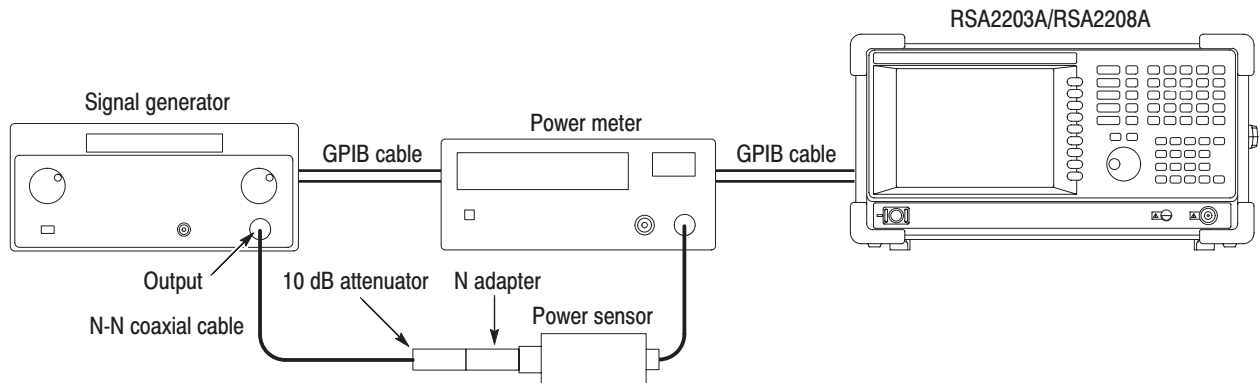

Figure 5-2: Initial test hookup

2. *Modify the default settings:*
 - a. Press **CAL** → **Service...** → **Password**.
 - b. Input **270833** and then press **ENTER** using the numeric keypad.
 - c. Press the **CAL** side key.
 - d. Press **MEASURE** → **SG Flatness**.
 - e. Press the **Power Sensor** side key and select the sensor number that you specified when storing calibration factors, with the general purpose knob.
 - f. Press the **Band** side key to select the measurement frequency band.
 - **230**. Measures from 1 MHz to 3 GHz for RSA2203A.
 - **Low**. Measures from 1 MHz to 3.5 GHz for RSA2208A.
 - **High**. Measures from 3.5 GHz to 8 GHz for RSA2208A.
 - g. Press the **SG** side key to select the manufacturer of the generator for the GPIB command system: HP or Anritsu.

NOTE. *The HP setting also supports Agilent and Rohde & Shwartz products.*

- h. Press the **GPIB Address** side key and set the address of the generator.
3. *Let the instruments warm up:* Allow a 20 minute warm-up period before you go to the next step.

4. *Calibrate the power sensor:*
 - a. *Modify the hookup:* Connect the power sensor input to the power reference output of the power meter (see Figure 5–3).

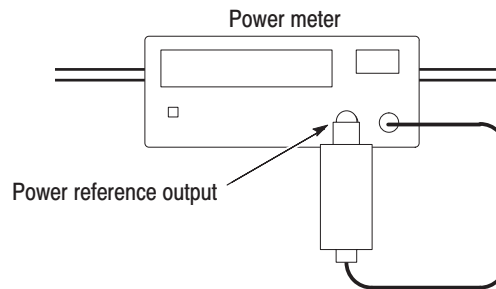

Figure 5-3: Hookup for calibrating the power sensor

- b. Press the **Sensor Cal** side key to perform zero adjustment and calibration for the sensor.
5. *Perform the flatness measurement for the generator:*
 - a. *Modify the hookup:* Connect the signal generator output through an N-N coaxial cable followed by a 10 dB attenuator and an N adapter to the power sensor input. See Figure 5–2 on page 5–7 again.
 - b. Insert a floppy disk to the disk drive of the analyzer for storing the flatness data.
 - c. Press the **Measurement** side key to perform the flatness measurement.

When the measurement has been completed, the flatness data is saved to the file(s) on the floppy disk:

sgrf1flatness.cal (for the Band setting of 230 and Low)
sgrf2flatness.cal (for the Band setting of High)
sgrf3flatness.cal (for the Band setting of High)

6. *Disconnect the hookup:*
 - a. Remove the floppy disk by pressing the eject button.
 - b. Turn off the signal generator, power meter, and analyzer.
 - c. Disconnect the GPIB cables.
 - d. Disconnect the power sensor and the N-N cable.

Self Calibration

Perform these routines to optimize the analyzer performance:

- Gain calibration
- Center offset calibration
- DC offset calibration

Each item is explained in this section.

Equipment Required	None
Prerequisites	Power on the analyzer and allow a 20 minute warm-up before doing this procedure.

Gain Calibration

The gain calibration calibrates the analyzer's amplifier gain using the internal signal generator. Run this internal calibration routine as required when you boot the analyzer or when UNCAL (uncalibrated) is displayed during operation.

Allow the analyzer to warm up for 20 minutes before you begin the calibration. The warm-up period allows electrical performance of the analyzer to stabilize.

During normal operation, when the ambient temperature changes by more than ± 5 °C from the temperature at the last calibration, UNCAL is displayed in the yellow box at the top of the screen (see Figure 5–4). If this happens, run the gain calibration

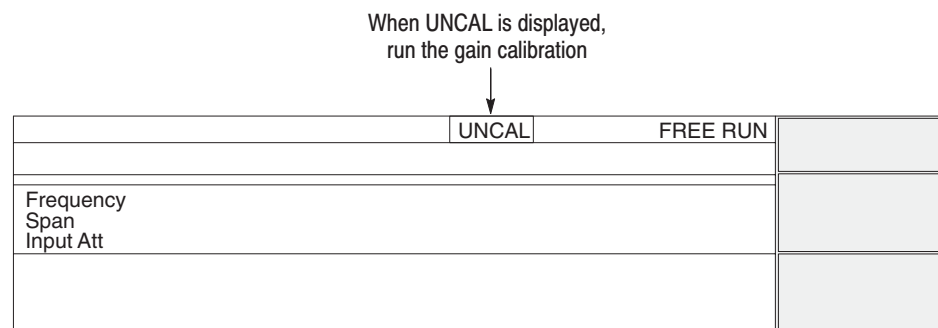

Figure 5–4: UNCAL display

To run the gain calibration, do the following:

NOTE. When you run the gain calibration during signal acquisition, the calibration begins after the acquisition is completed.

1. Press the **CAL** key on the front panel (see Figure 5–5).
2. Press the **Calibrate Gain** side key.

The calibration runs. It takes several seconds to complete the process.

When you want to perform the gain, center offset, and DC offset calibration together, press the **Calibrate All** side key.

3. If you press the **Auto Calibration** side key to select **Yes**, the calibration will run automatically any time the analyzer gain drifts to an uncal state.

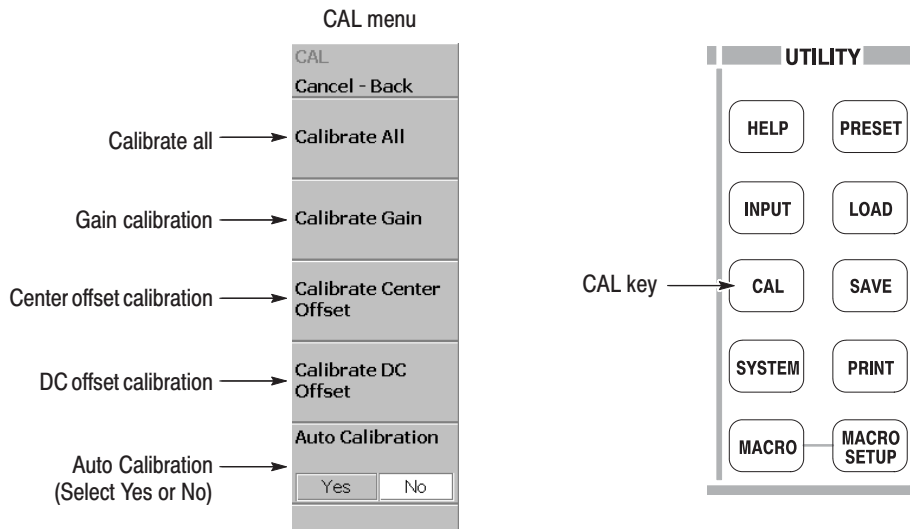

Figure 5–5: Calibration menu

Center Offset Calibration

When you display a spectrum and no input signal is present, a spurious emission at the center frequency may appear regardless of frequency settings. The center offset calibration cancels those spurious emissions. If the spurious emission is too obvious when you narrow the span, run the calibration.

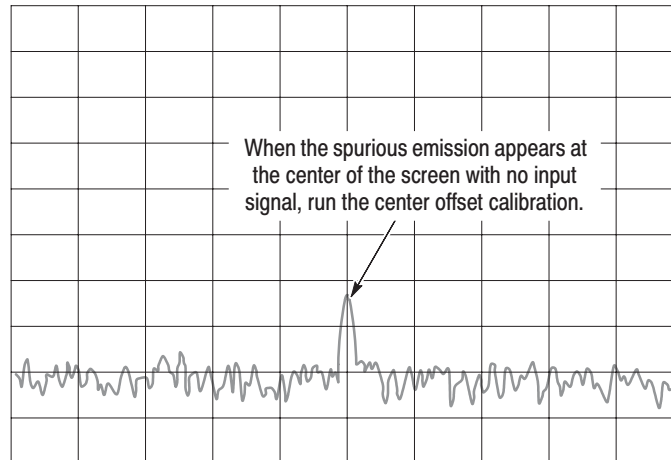

Figure 5-6: Center offset

1. Press the **CAL** key on the front panel (see Figure 5-5).
2. Press the **Calibrate Center Offset** side key.

The calibration runs. It takes several seconds to complete the process.

When you want to perform the gain, center offset, and DC offset calibration together, press the **Calibrate All** side key.

NOTE. Enabling Auto Calibration (see Figure 5-5) allows the analyzer to run the center offset calibration automatically as analyzer settings change.

**DC Offset Calibration
(Option 05 Only)**

The DC offset calibration cancels DC offset that appears at 0 Hz in the baseband. When you change the amplitude setting and the DC offset is too obvious, run the DC offset calibration.

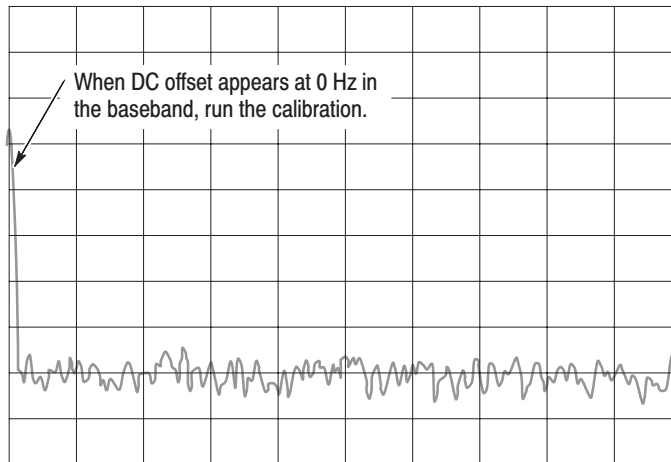

Figure 5-7: DC offset

1. Press the **CAL** key on the front panel (see Figure 5-5).
2. Press the **Calibrate DC Offset** side key.

The calibration runs. It takes several seconds to complete the process.

When you want to perform the gain, center offset, and DC offset calibration together, press the **Calibrate All** side key.

Auto Calibration

The auto calibration uses the internal routines to adjust gain and flatness of the analyzer.

Equipment Required	One signal generator (Items 1) One signal generator (Item 2, for RSA2208A only) One 50 Ω N-N coaxial cable (Item 7) Two GPIB cables (Item 8) One RF attenuator (Item 10) One SG flatness floppy disk (Item 14)
Prerequisites	Refer to page 5-1

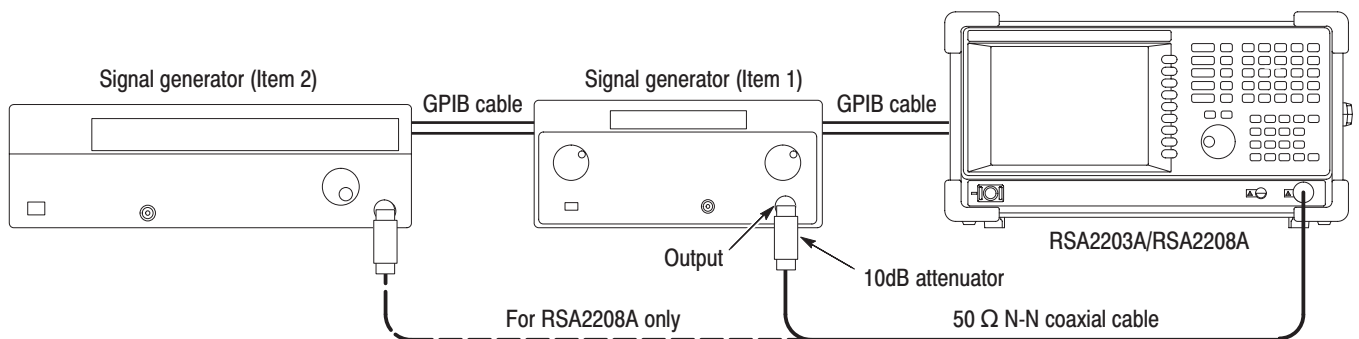

Figure 5-8: Initial test hookup

1. *Prepare for the adjustment:*

- a. Power off the RSA2203A/RSA2208A analyzer, the signal generator(s).
- b. Connect the analyzer and the generator(s) with GPIB cables.
See Figure 5–8.
- c. Connect the signal generator (Item 1) output through a 10 dB attenuator (Item 10) followed by a 50 Ω N-N coaxial cable to the analyzer **INPUT**.
- d. Power on the analyzer and the generator(s).
- e. Set the GPIB address of the generator(s):
 - Signal generator (Item 1) 1 or 5
 - Signal generator (Item 2) 1 or 5 (not the same as above)
- f. Insert the SG flatness floppy disk (Item 14) for the signal generator (Item 1) to the disk drive of the analyzer.
- g. *Initialize the analyzer:*
 - Press the **SYSTEM** key on the front panel.
 - Press the **Reset All to Factory Defaults** side key.

2. *Modify the analyzer settings:*

- a. Press the **CAL** key on the front panel.
- b. Press the side key **Service...→ Password**.
- c. Input **270833** and then press **ENTER** using the numeric keypad.
- d. Press the **CAL** side key.
- e. Press the **SG Address** side key to set the GPIB address of the generator: 1 or 5.
- f. Press the **SG Type** side key to select the manufacturer of the generator: HP or Anritsu.

NOTE. *The HP setting also supports Agilent and Rohde & Shwartz products.*

- g. Press the **Target Files** side key to select the calibration items:
 - **All.** Perform all calibration. The results are overwritten to the existing log files.
 - **Absent.** Perform the calibration that has no log file.

3. *Perform calibration in the baseband (Option 05 only):*
 - a. Press the **BB** side key to perform calibration.

NOTE. *Alternatively, you can select BB + RF1 to perform calibration in both the baseband and the RF (RSA2203A) / RF1 (RSA2208A) band. In this case, skip to step 5.*

- b. *Wait.* It takes several minutes to complete the calibration.
4. *Perform calibration in the RF (RSA2203A) / RF1 (RSA2208A) band:*
 - a. Press the **RF1** side key to perform calibration.
 - b. *Wait.* It takes several minutes to complete the calibration.
5. *Modify the hookup:*
 - a. Disconnect the 10 dB attenuator at the generator output.
 - b. Connect the generator (Item 2) output through a 10 dB attenuator followed by a 50 Ω N-N coaxial cable to the analyzer **INPUT**.
 - c. *Replace the SG flatness floppy disk:*
 - Eject the SG flatness floppy disk from the disk drive of the analyzer.
 - Insert the SG flatness floppy disk for the signal generator (Item 2).
6. *Perform calibration in the RF2 band for RSA2208A only:*
 - a. Press the **RF2** side key to perform calibration.

NOTE. *RSA2208A only. Alternatively, you can select RF2+RF3 to perform calibration in RF2 and RF3 bands. In this case, skip to step 8.*

- b. *Wait.* It takes several minutes to complete the calibration.
7. *Perform calibration in the RF3 band for RSA2208A only:*
 - a. Press the **RF3** side key to perform calibration.
 - b. *Wait.* It takes several minutes to complete the calibration.
8. *Disconnect the test equipment:*
 - a. Disconnect the cable from the analyzer input.
 - b. Turn off the analyzer and generators.
 - c. Disconnect the GPIB cables from all the ports.

Reference Oscillator Frequency Adjustment

This procedure adjusts the output frequency of the 10 MHz internal reference oscillator.

Equipment Required	One frequency counter (Item 3) One 50 Ω BNC coaxial cable (Item 6) One 50 Ω terminator (Item 9) One adjustment tool (Item 15)
Prerequisites	Warm up the analyzer for more than 20 minutes and the frequency counter for more than 24 hours.

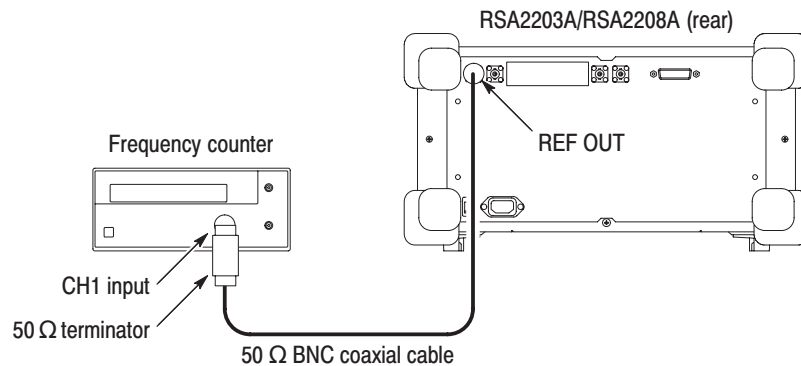

Figure 5-9: Initial test hookup

1. *Prepare for the adjustment:*
 - a. *Access the inside of the analyzer:* See *Removal and Installation Procedures* in Section 6 to remove the cabinet.
 - b. *Hook up the frequency counter:* Connect **REF OUT** on the rear panel of the analyzer through a 50 Ω precision coaxial cable and a 50 Ω precision terminator to Channel 1 of the counter. See Figure 5-9.
 - c. *Set the counter controls:*

Function Frequency 1
 Gate time 2 s

2. *Adjust the reference frequency:* Adjust R232 on the A500 step amplifier/oscillator interface board in the RF5 module so that the frequency counter reads 10 MHz \pm 0.1 Hz. See Figure 5-10 for the R232 location.

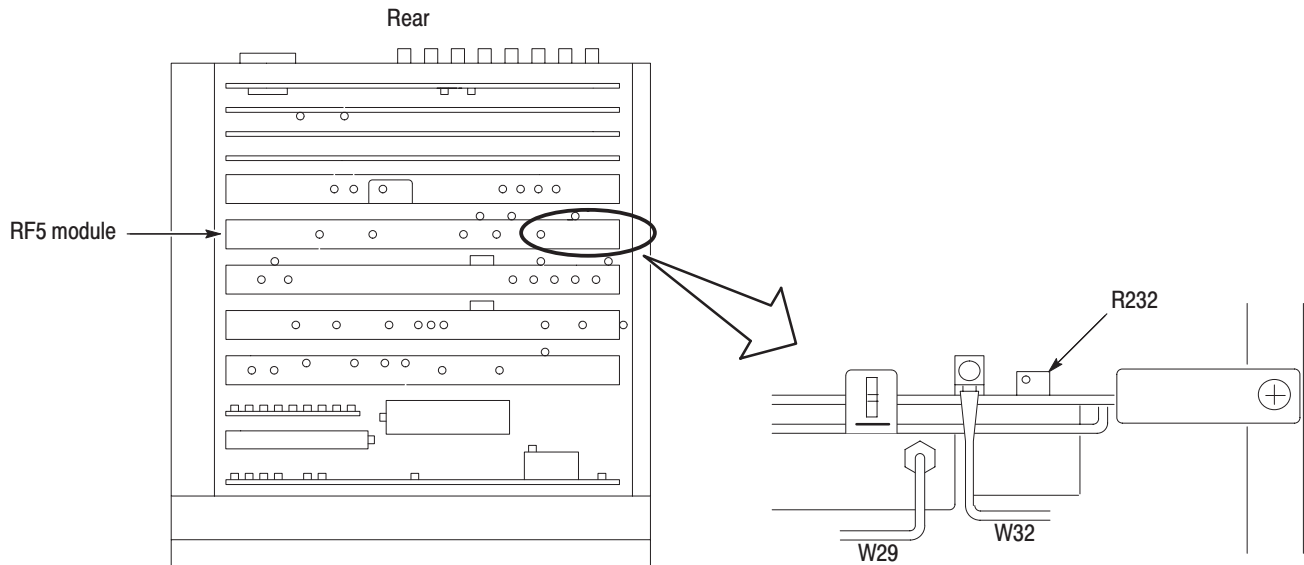

Figure 5-10: R232 location (top view of the card cage)

3. *Restore the analyzer to normal operation:*
 - a. Power off the analyzer.
 - b. Refer to *Removal and Installation Procedures* in Section 6 to reinstall the cabinet and other modules removed in step 1.

Reconfiguration of RF Modules

The following procedures update the down-converter configuration file when replacing the RF3 module and/or YTF unit. The procedure for the YTF unit is for the RSA2208A analyzer only.

STOP. Before doing the following procedures, note the gain and offset values which are indicated on the front surface of the module.

Reconfiguration of the RF3 Module

When replacing the RF3 module, do the following procedure.

Equipment Required	One signal generator (Item 1) One 50 Ω N-N coaxial cable (Item 7)
---------------------------	---

1. *Modify the RF3 DAC setting:*
 - a. Press the **CAL** key on the front panel.
 - b. Press the side key **Service...** → **Password**.
 - c. Input **270833** and then press **ENTER** using the numeric keypad.
 - d. Press the side key **DEBUG** → **YTO Tune DAC...**
 - e. Press the **Gain** side key and input the gain of the RF3 module.
 - f. Press the **Offset** side key and input the offset of the RF3 module.
2. *Prepare for the adjustment:*
 - a. *Set the signal generator controls:*

Frequency	1500 MHz
Amplitude	-10 dBm
RF Output	On

- b. *Hook up the signal generator:* Connect the generator output through a 50 Ω N-N coaxial cable to the analyzer **INPUT**. See Figure 5–11.

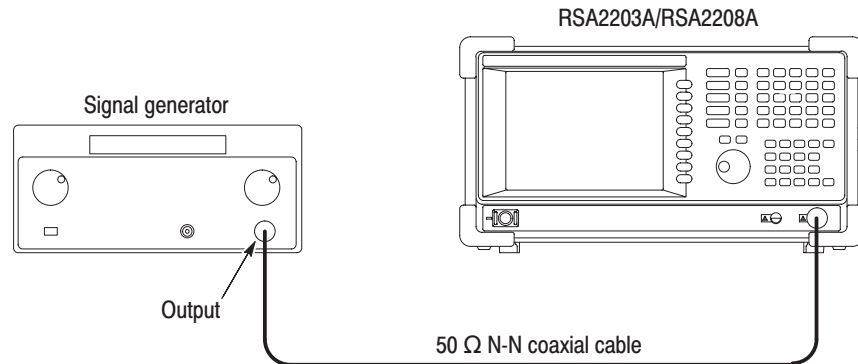

Figure 5–11: Test hookup

- c. *Initialize the analyzer:*
- Press the **SYSTEM** key on the front panel.
 - Press the **Reset All to Factory Defaults** side key.
- d. *Modify the default settings:*
- Press the **SPAN** key on the front panel.
 - With the **Span** side key, set the span to 3 GHz using the numeric keypad.
3. *Check the spectrum:* Confirm that a spectrum displays at 1.5 GHz.
4. *Disconnect the test equipment:* Disconnect the cable at **INPUT**.

Reconfiguration of the YTF unit (RSA2208A Only)

When replacing the YTF unit for RSA2208A, do the following procedure.

Equipment Required	One signal generator (Item 2) One 50 Ω N-N coaxial cable (Item 7)
---------------------------	---

1. *Modify the YTF unit DAC setting:*
 - a. Press the **CAL** key on the front panel.
 - b. Press the side key **Service...** → **Password**.
 - c. Input **270833** and then press **ENTER** using the numeric keypad.
 - d. Press the side key **DEBUG** → **YTF Tune DAC...**
 - e. Press the **Gain** side key and input the gain of the YTF unit.
 - f. Press the **Offset** side key and input the offset of the YTF unit.
2. *Prepare for the adjustment:*
 - a. *Set the signal generator controls:*

Frequency 6500 MHz
Amplitude -10 dBm
RF Output On
 - b. *Hook up the signal generator:* Connect the generator output through a 50 Ω N-N coaxial cable to the analyzer **INPUT**. See Figure 5–12.

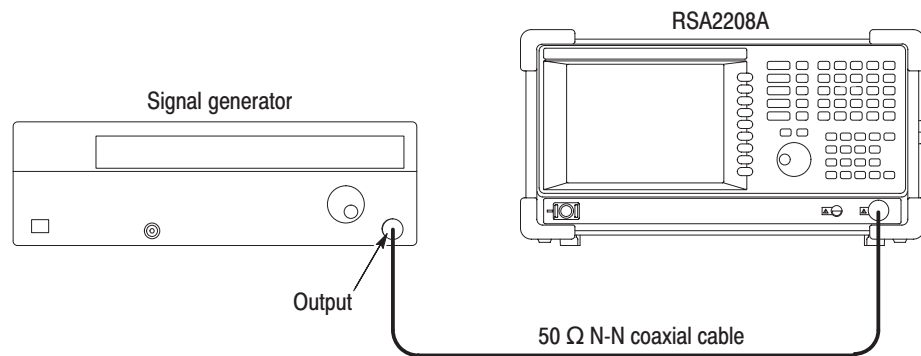

Figure 5–12: Test hookup

- c. *Initialize the analyzer:*
 - Press the **SYSTEM** key on the front panel.
 - Press the **Reset All to Factory Defaults** side key.
 - d. *Modify the default settings:*
 - Press the **FREQUENCY/CHANNEL** key on the front panel.
 - With the **Center Freq** side key, set the frequency to 6.5 GHz using the numeric keypad.
 - Press the **SPAN** key on the front panel.
 - With the **Span** side key, set the span to 3 GHz using the numeric keypad.
3. *Check the spectrum:* Confirm that a spectrum displays at 6.5 GHz.
4. *Disconnect the test equipment:* Disconnect the cable at **INPUT**.

Maintenance

Maintenance

This section contains the information needed to do periodic and corrective maintenance on the RSA2203A and RSA2208A Real-Time Spectrum Analyzers. The following subsections are included:

- *Preparation* — Introduction plus general information on preventing damage to internal modules when doing maintenance.
- *Inspection and Cleaning* — Information and procedures for inspecting the analyzer and cleaning its external and internal modules.
- *Removal and Installation Procedures* — Procedures for the removal of defective modules and replacement of new or repaired modules. Also included is a procedure for disassembly of the analyzer for cleaning.
- *Troubleshooting* — Information for isolating and troubleshooting failed modules. Included are instructions for operating the analyzer's internal diagnostic routines and troubleshooting trees.

Related Maintenance Procedures

The following sections contain information and procedures related to maintenance.

- Section 2, *Operating Information*, covers instructions useful when operating the analyzer in order to troubleshoot it. It also details the service strategy and lists options for obtaining maintenance service and for replacing failed modules.
- Section 3, *Theory of Operation*, contains a circuit description at the module, or block, level.
- Section 4, *Performance Verification*, contains procedures that may be useful in isolating problems to modules by testing analyzer performance.
- Section 5, *Adjustment Procedures*, addresses after repair adjustment and the interval between periodic adjustments. Procedures for adjusting the analyzer are included in this section.
- Section 9, *Diagrams*, contains a block diagram using individual modules as blocks and an interconnection diagram showing connections between modules.
- Section 10, *Mechanical Parts List*, lists all field replaceable modules by part number.

Preparation

Before servicing this product, read the *Safety Summary* and *Introduction* at the front of the manual and the ESD information below.



CAUTION. *Static discharge can damage any semiconductor component in this analyzer.*

Preventing ESD

When performing any service that requires internal access to the analyzer, adhere to the following precautions to avoid damaging internal modules and their components due to electrostatic discharge (ESD).

1. Minimize handling of static-sensitive modules.
2. Transport and store static-sensitive modules in their static protected containers or on a metal rail. Label any package that contains static-sensitive modules.
3. Discharge the static voltage from your body by wearing a grounded antistatic wrist strap while handling these modules. Do service of static-sensitive modules only at a static-free work station.
4. Nothing capable of generating or holding a static charge should be allowed on the work station surface.
5. Handle circuit boards by the edges when possible.
6. Do not slide the modules over any surface.
7. Avoid handling modules in areas that have a floor or work-surface covering capable of generating a static charge.

Susceptibility to ESD

Table 6–1 lists the relative susceptibility of various classes of semiconductors. Static voltages of 1 kV to 30 kV are common in unprotected environments.

Table 6–1: Relative susceptibility to static-discharge damage

Semiconductor classes	Relative susceptibility levels¹
MOS or CMOS microcircuits or discrete circuits, or linear microcircuits with MOS inputs (most sensitive)	1
ECL	2
Schottky signal diodes	3
Schottky TTL	4
High-frequency bipolar transistors	5
JFET	6
Linear microcircuits	7
Low-power Schottky TTL	8
TTL (least sensitive)	9

¹ **Voltage equivalent for levels (voltage discharged from a 100 pF capacitor through resistance of 100 ohms):**

1 = 100 to 500 V	6 = 600 to 800 V
2 = 200 to 500 V	7 = 400 to 1000 V (est.)
3 = 250 V	8 = 900 V
4 = 500 V	9 = 1200 V
5 = 400 to 600 V	

Inspection and Cleaning

Inspection and Cleaning describes how to inspect for dirt and damage. It also describes how to clean the exterior and interior of the analyzer. Inspection and cleaning are done as preventive maintenance. Preventive maintenance, when done regularly, may prevent analyzer malfunction and enhance its reliability.

Preventive maintenance consists of visually inspecting and cleaning the analyzer and using general care when operating it.

How often to do maintenance depends on the severity of the environment in which the analyzer is used. A proper time to perform preventive maintenance is just before analyzer adjustment.

General Care

The cabinet helps keep dust out of the analyzer and should normally be in place when operating the analyzer.

Inspection and Cleaning Procedures

Inspect and clean the analyzer as often as operating conditions require. The collection of dirt on components inside can cause them to overheat and breakdown. (Dirt acts as an insulating blanket, preventing efficient heat dissipation.) Dirt also provides an electrical conduction path that could cause an analyzer failure, especially under high-humidity conditions.



CAUTION. *Avoid the use of chemical cleaning agents, which might damage the plastics used in this analyzer. Use only deionized water when cleaning the menu buttons or front-panel buttons. Use a 75% isopropyl alcohol solution as a cleaner and rinse with deionized water. Before using any other type of cleaner, consult your Tektronix Service Center or representative.*

Inspection — Exterior. Inspect the outside of the analyzer for damage, wear, and missing parts, using Table 6–2 as a guide. Analyzers that appear to have been dropped or otherwise abused should be checked thoroughly to verify correct operation and performance. Immediately repair defects that could cause personal injury or lead to further damage to the analyzer.

Table 6–2: External inspection check list

Item	Inspect for	Repair action
Cabinet, front panel, and cover	Cracks, scratches, deformations, damaged hardware or gaskets.	Repair or replace defective module.
Front-panel knobs	Missing, damaged, or loose knobs.	Repair or replace missing or defective knobs.
Connectors	Broken shells, cracked insulation, and deformed contacts. Dirt in connectors.	Repair or replace defective modules. Clear or wash out dirt.
Carrying handle, bail, cabinet feet.	Correct operation.	Repair or replace defective module.
Accessories	Missing items or parts of items, bent pins, broken or frayed cables, and damaged connectors.	Repair or replace damaged or missing items, frayed cables, and defective modules.

Cleaning Procedure — Exterior. To clean the analyzer exterior, do the following steps:

1. Remove loose dust on the outside of the analyzer with a lint free cloth.
2. Remove remaining dirt with a lint free cloth dampened in a general purpose detergent-and-water solution. Do not use abrasive cleaners.
3. Clean the light filter protecting the monitor screen with a lint-free cloth dampened with either isopropyl alcohol or, preferably, a gentle, general purpose detergent-and-water solution.



CAUTION. To prevent getting moisture inside the analyzer during external cleaning, use only enough liquid to dampen the cloth or applicator.

Inspection — Interior. To access the inside of the analyzer for inspection and cleaning, refer to the *Removal and Installation Procedures* in this section.

Inspect the internal portions of the analyzer for damage and wear, using Table 6–3 as a guide. Defects found should be repaired immediately.



CAUTION. *To prevent damage from electrical arcing, ensure that circuit boards and components are dry before applying power to the analyzer.*

Table 6-3: Internal inspection check list

Item	Inspect for	Repair action
Circuit boards	Loose, broken, or corroded solder connections. Burned circuit boards. Burned, broken, or cracked circuit-run plating.	Remove failed module and replace with a new module.
Wiring and cables	Loose plugs or connectors. Burned, broken, or frayed wiring.	Firmly seat connectors. Repair or replace the modules that have defective wires or cables.
Chassis	Dents, deformations, and damaged hardware.	Straighten, repair, or replace defective hardware.

Cleaning Procedure — Interior. To clean the analyzer interior, do the following steps:

1. Blow off dust with dry, low-pressure, deionized air (approximately 9 psi).
2. Remove any remaining dust with a lint-free cloth dampened in isopropyl alcohol (75% solution) and rinse with warm deionized water. (A cotton-tipped applicator is useful for cleaning in narrow spaces and on circuit boards.)

STOP. *For further cleaning, contact your local Tektronix service center.*

Removal and Installation Procedures

This subsection contains procedures for removal and installation of all mechanical and electrical modules. Any electrical or mechanical assembly, or part listed in Section 10 of this manual is a module.

Preparation



WARNING. Before doing this or any other procedure in this manual, read the Safety Summary found at the beginning of this manual. Also, to prevent possible injury to service personnel or damage to this analyzer's components, read Installation in Section 2, and Preventing ESD in this section.

This subsection contains the following items:

- This preparatory information that you need to properly do the procedures that follow.
- List of tools required to remove and disassemble all modules.
- Nine module locator diagrams for finding the External modules (see Figure 6-2), RF modules (see Figure 6-3), CPU board and disk modules (see Figure 6-4), Mother board and its daughter boards (see Figure 6-5), Bottom modules – Power supply (see Figure 6-6), Bottom modules – RF1 for RSA2203A (see Figure 6-7), Bottom modules – RF1 for RSA2208A (see Figure 6-8), Front panel modules (see Figure 6-9), and Chassis modules (see Figure 6-10) in this analyzer.
- Procedures for removal and reinstallation of the electrical and mechanical modules.
- A disassembly procedure for removal of all the major modules from the analyzer at one time and for reassembly of those modules into the analyzer. Such a complete disassembly is normally only done when completely cleaning the analyzer. (Instructions for doing the actual cleaning are found under *Inspection and Cleaning* at the beginning of this section.)



WARNING. Before doing any procedure in this subsection, disconnect the power cord from the line voltage source. Failure to do so could cause serious injury or death.

List of Modules Section 10 lists all modules.

General Instructions ***STOP. READ THESE GENERAL INSTRUCTIONS BEFORE REMOVING A MODULE.***

First read over the Summary of Procedures that follows to understand how the procedures are grouped. Then read Equipment Required for a list of the tools needed to remove and install modules in this analyzer.

If you are removing a module for service, begin by doing the procedure Access Procedure (page 6–21). By following the instructions in that procedure, you remove the module to be serviced while removing the minimum number of additional modules.

Summary of Procedures

The procedures are described in the order in which they appear in this section. In addition, you can look up any procedure for removal and reinstallation of any module in the *Table of Contents* of this manual.

The *Access Procedure* on page 6–21 first directs you to the procedure(s) (if any) that are required to access the module to be serviced, then it directs you to the procedure to remove that module.

Table 6-4: Summary of procedures

Procedure	Module	Page
Procedures for external modules	<ul style="list-style-type: none"> ■ Line cord ■ Cabinet ■ Front cushion ■ Cabinet modules 	6-22
Procedures for RF Modules	<ul style="list-style-type: none"> ■ RF2 module ■ RF3 module ■ RF4 module ■ RF5 module 	6-27
Procedures for CPU board and disk modules	<ul style="list-style-type: none"> ■ CPU board ■ Hard disk drive ■ Floppy disk drive ■ A62 Front connection board 	6-31
Procedures for mother board and its daughter boards	<ul style="list-style-type: none"> ■ A10 A/D board ■ A41 SRAM board ■ A50 Mother board ■ A70 DC power board 	6-36
Procedures for power supply modules on the bottom	<ul style="list-style-type: none"> ■ Power supply 1 ■ Power supply 2 ■ Power supply 3 ■ A71 AC power board ■ Line filter ■ Principal power switch 	6-42
Procedures for RF1 modules on the bottom	<ul style="list-style-type: none"> ■ A100 Interconnection board ■ Step attenuator 1 ■ Step attenuator 2 ■ Input relay ■ Band relay ■ Programmable band-pass filter ■ A150 YTF interface board 	6-47
Procedures for front panel modules	<ul style="list-style-type: none"> ■ Front panel assembly ■ Front bezel ■ Menu buttons ■ Front panel ■ Rotary encoder ■ LCD display ■ A60 Front key board ■ A61 Power switch board ■ RF input connector ■ Preamp power connector 	6-54
Procedures for chassis modules	<ul style="list-style-type: none"> ■ Fan ■ Side panel assembly ■ Board guide bracket ■ Rear panel modules 	6-60

Equipment Required. Most modules in this analyzer can be removed with a screwdriver with a size #2, Phillips tip. *Use this tool whenever a procedure step instructs you to remove or install a screw unless a different size screwdriver is specified in that step.* All equipment required to remove and reinstall a module are listed in the first step of each procedure.

Table 6-5: Tools required for module removal

Item No.	Name	Description	Tektronix part number
1	Screwdriver handle	Accepts $\frac{1}{4}$ inch hex-head driver tips	
2	#1 Phillips tip	Phillips-driver bit for #1 size screw heads	
3	#2 Phillips tip	Phillips-driver bit for #2 size screw heads	
4	Flat-bladed screwdriver	Screwdriver for removing standard-headed screws	
5	SMA torque driver	Accepts SMA hex-head driver bits	003-1423-91
6	Long type bit	Long type bit (H 8 mm \times L 130 mm) for SMA/3.5 mm connector	003-1422-00
7	Nutdriver, 12 mm	Standard tool	
8	Nutdriver, 14 mm	Standard tool	
9	Nutdriver, $\frac{9}{16}$ inch	Standard tool	
10	Wrench, $\frac{1}{16}$ inch	Standard tool	
11	Wrench, $\frac{5}{16}$ inch	Standard tool	
12	Needle-nose pliers	Standard tool	
13	Retaining ring pliers	Standard tool; $1\frac{1}{8}$ inch minimum throw	
14	Angle-tip tweezers	Standard tool	
15	Pliers	Standard tool	
16	Soldering iron	Standard tool	
17	Solder wick	Standard tool	
18	Adhesive	TRA-CON: Tra-Bond #BA-2114	

Analyzer Orientation Figure 6-1 shows how the sides of the analyzer are referenced in this manual.

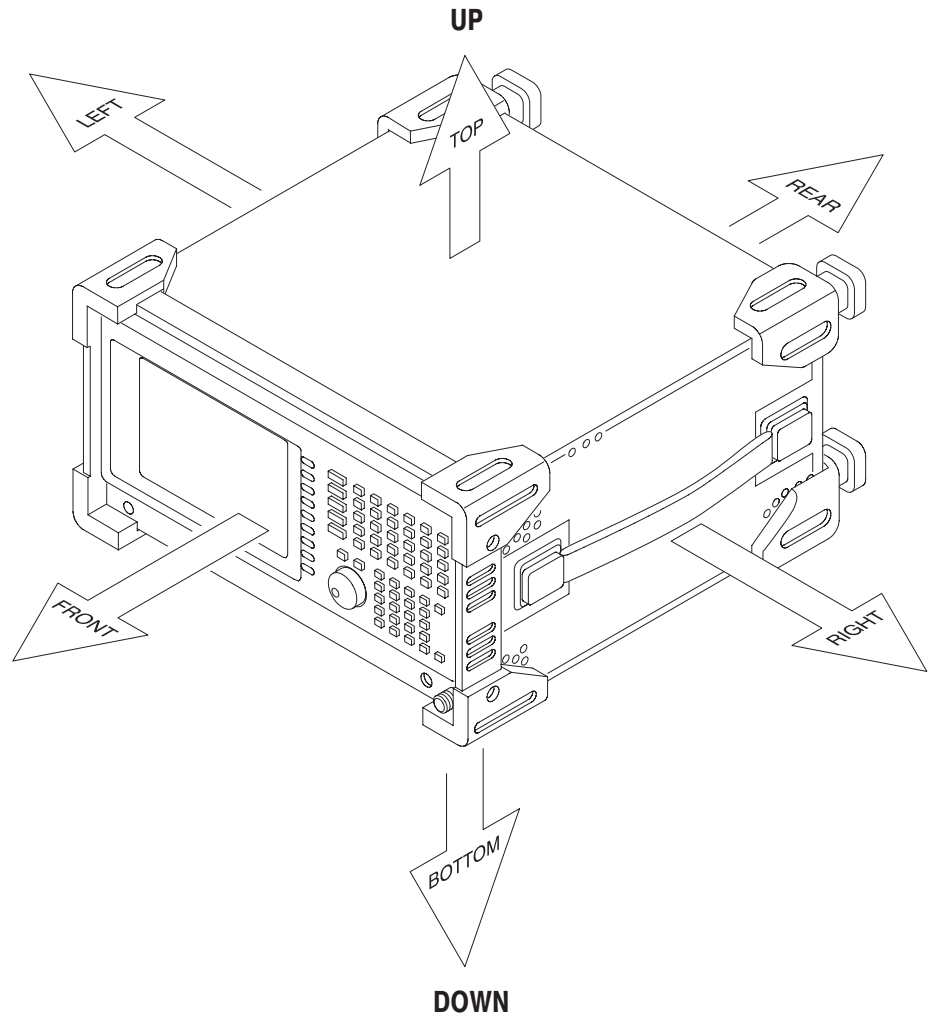

Figure 6-1: Analyzer orientation

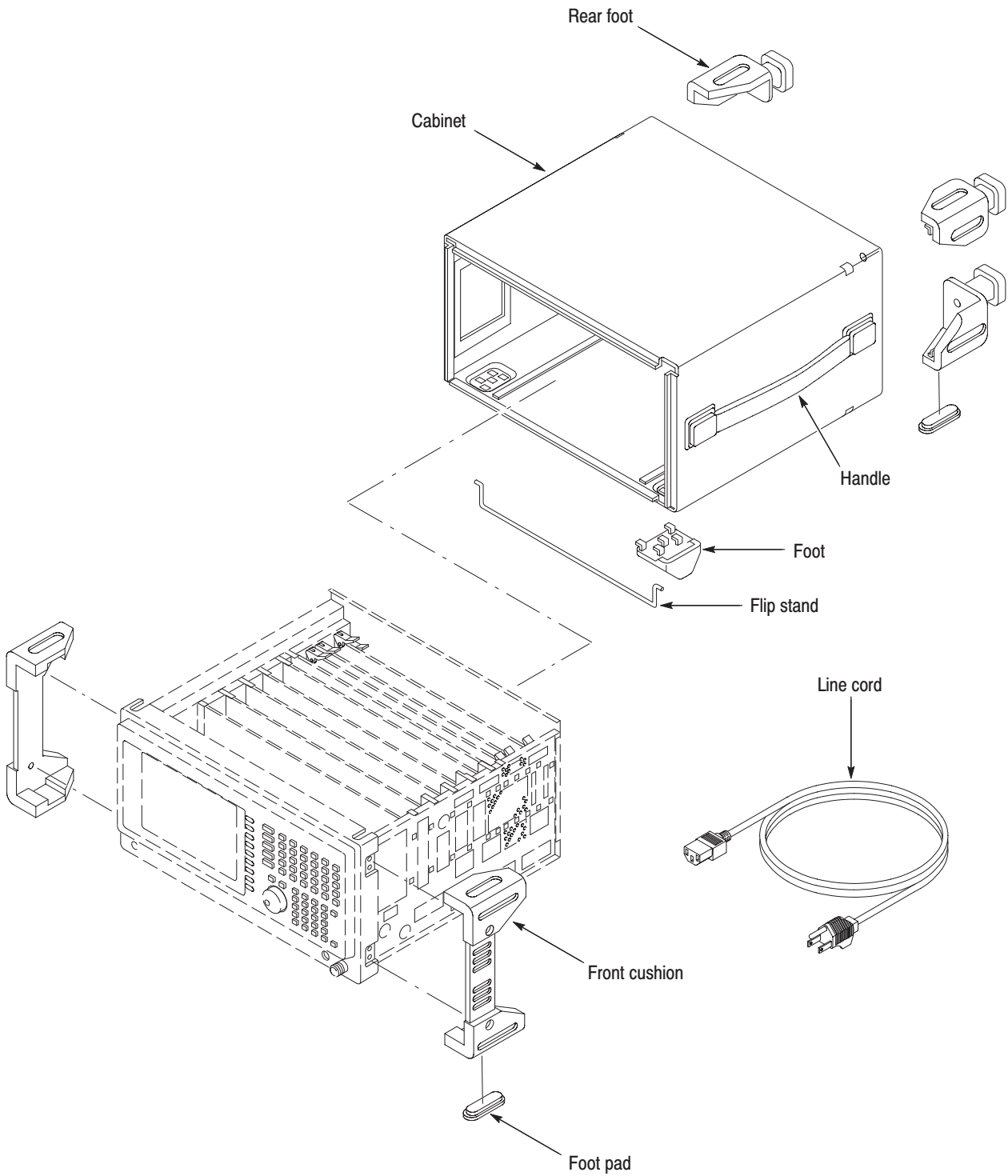

Figure 6-2: External modules

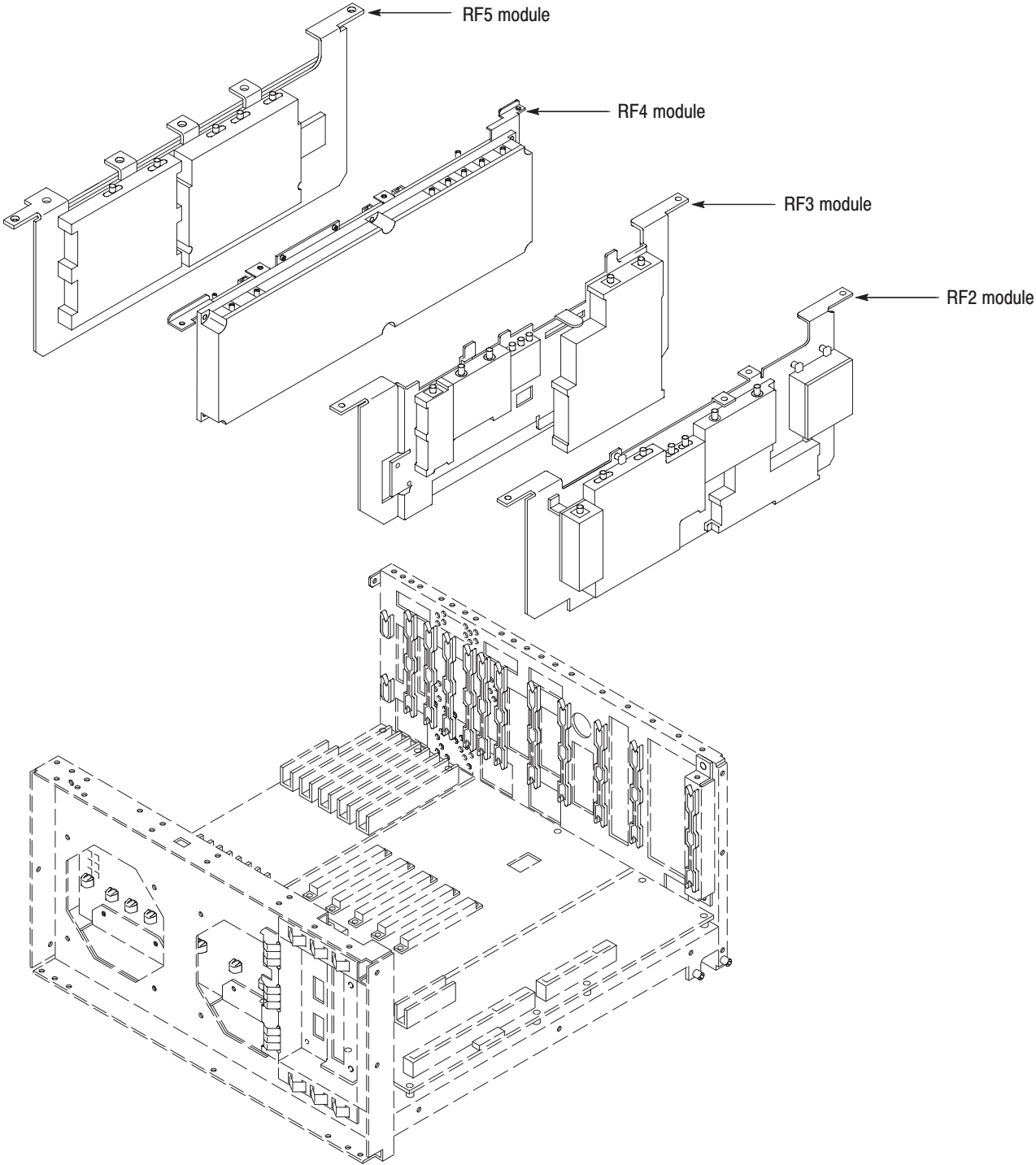

Figure 6-3: RF modules

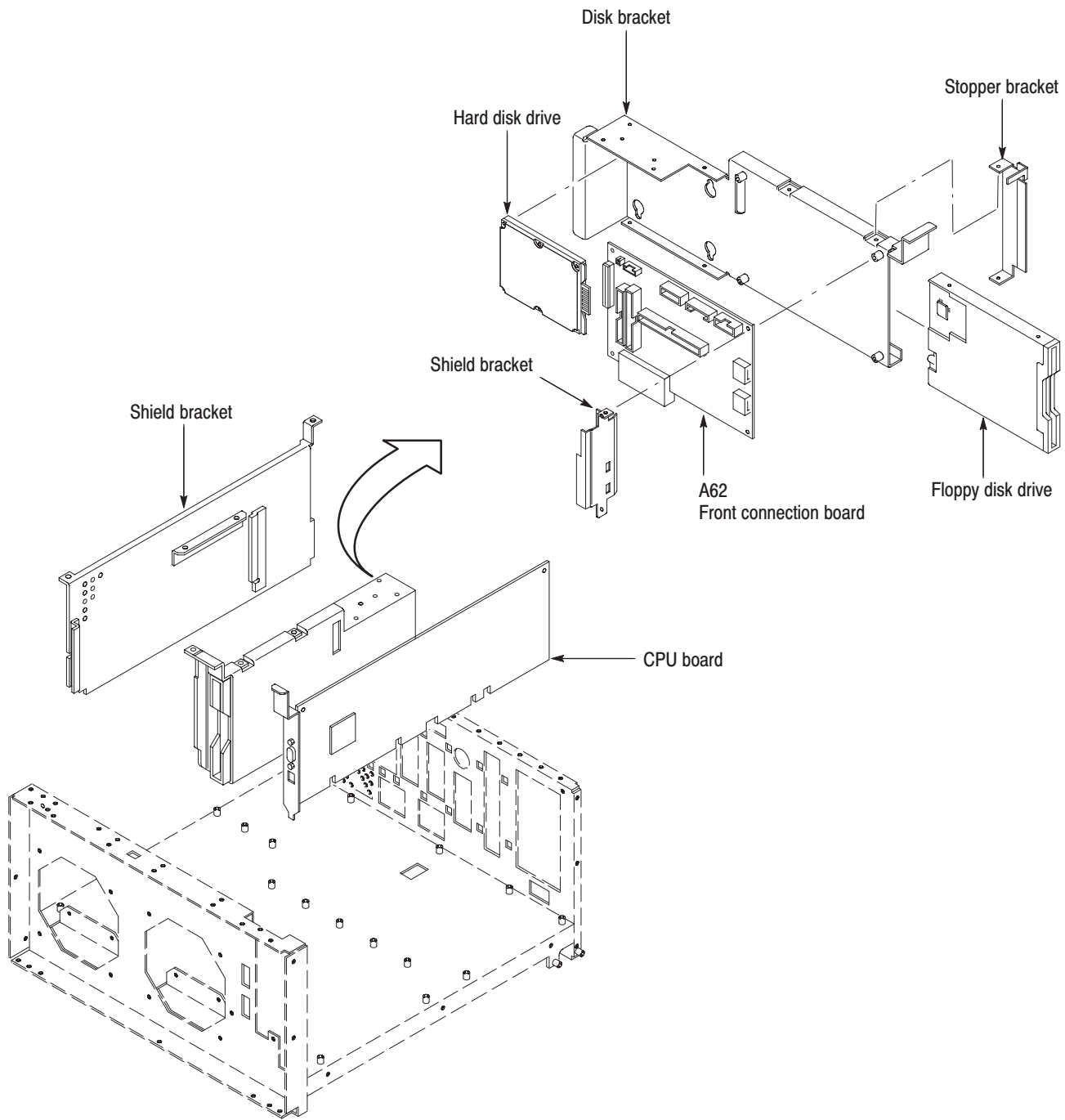

Figure 6-4: CPU board and disk modules

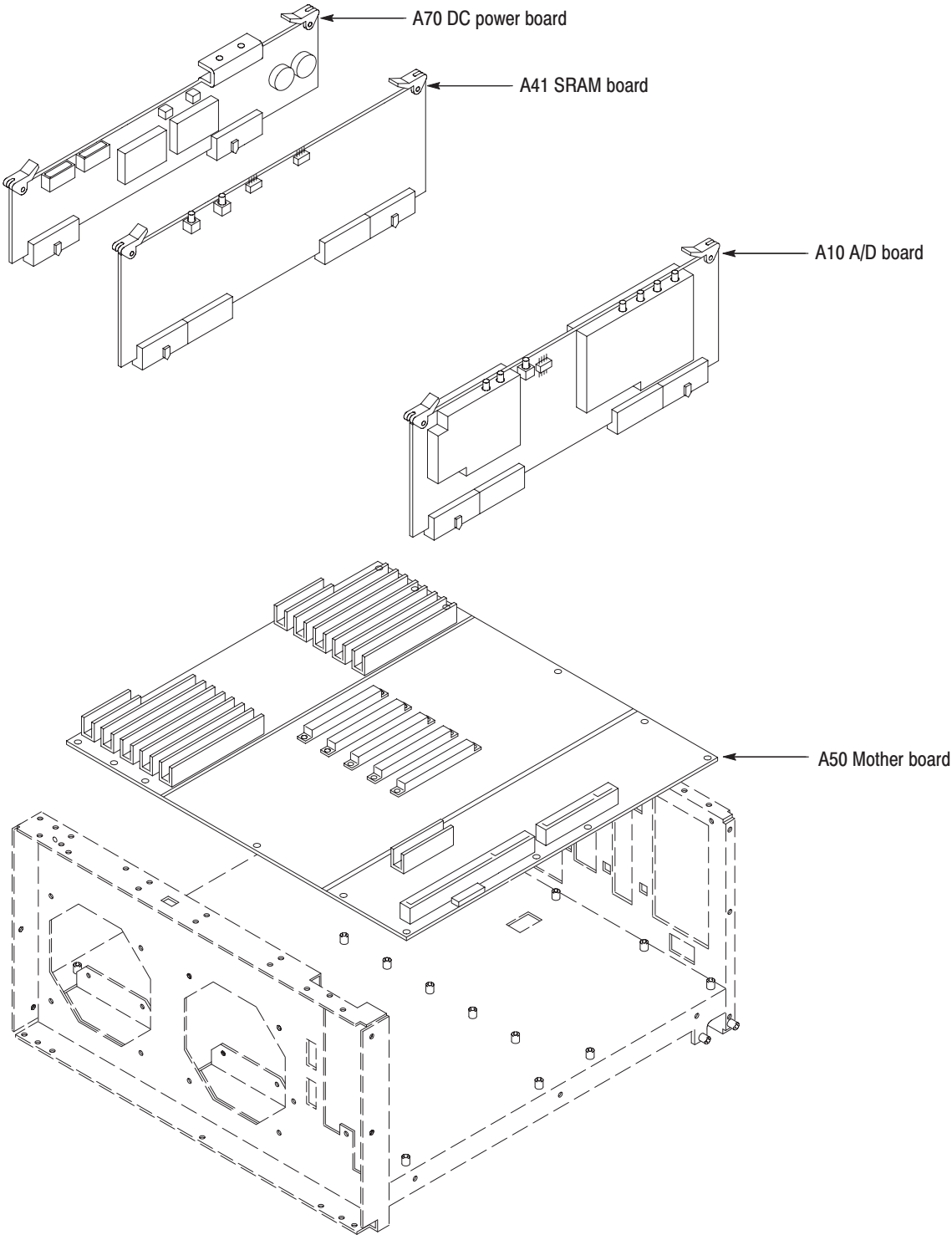

Figure 6-5: Mother board and its daughter boards

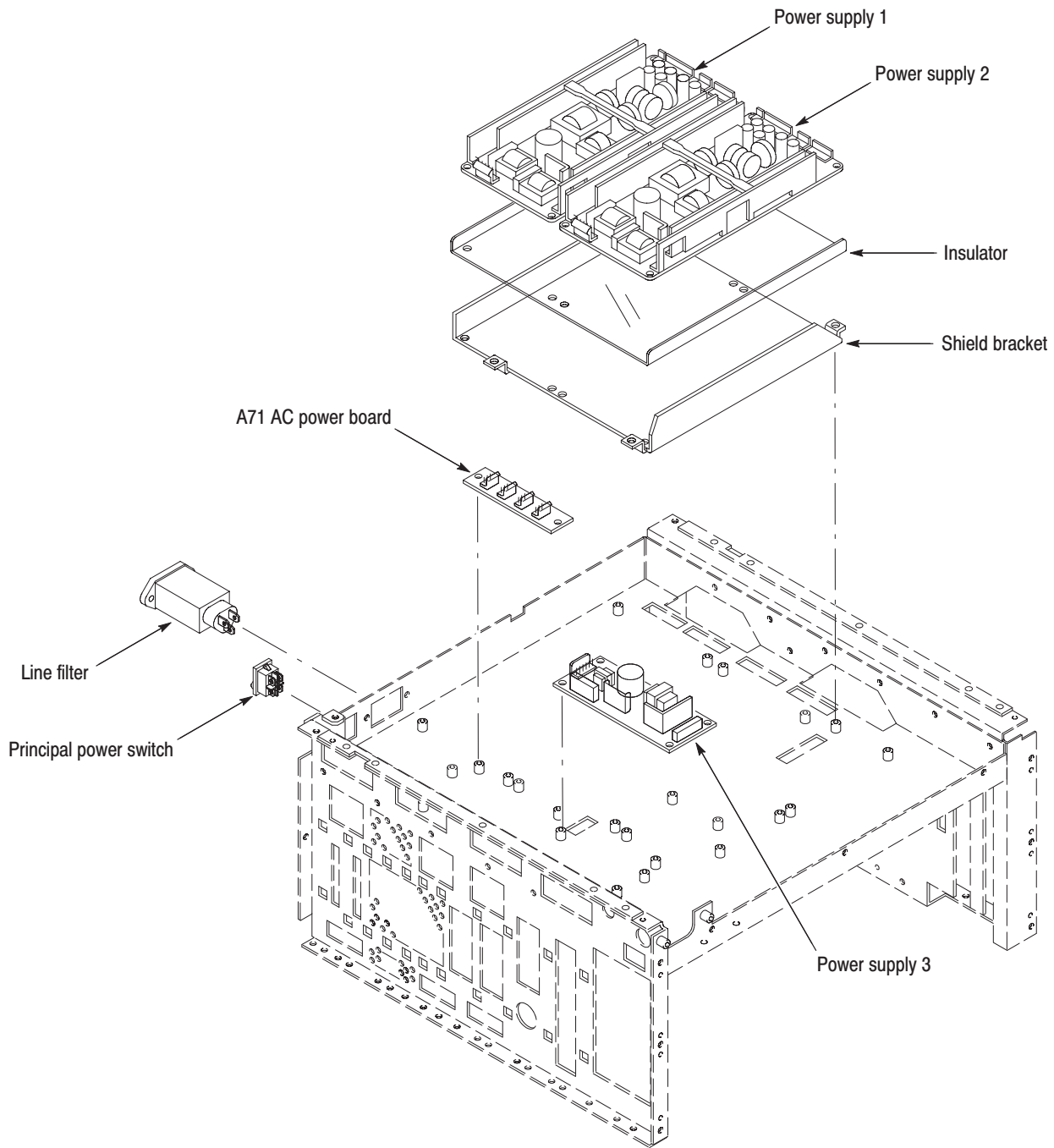

Figure 6-6: Bottom modules - Power supply

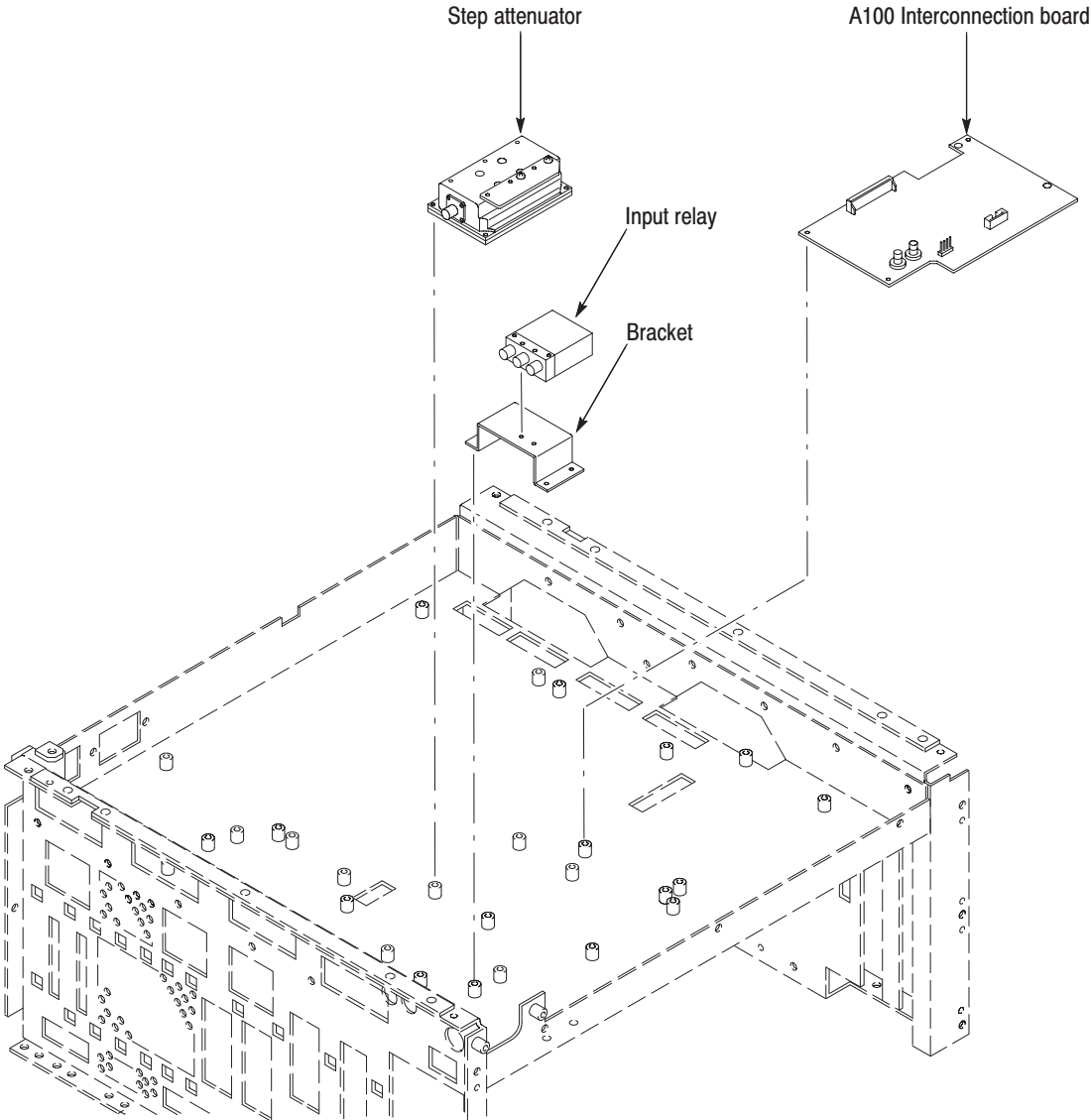

Figure 6-7: Bottom modules - RF1 (RSA2203A)

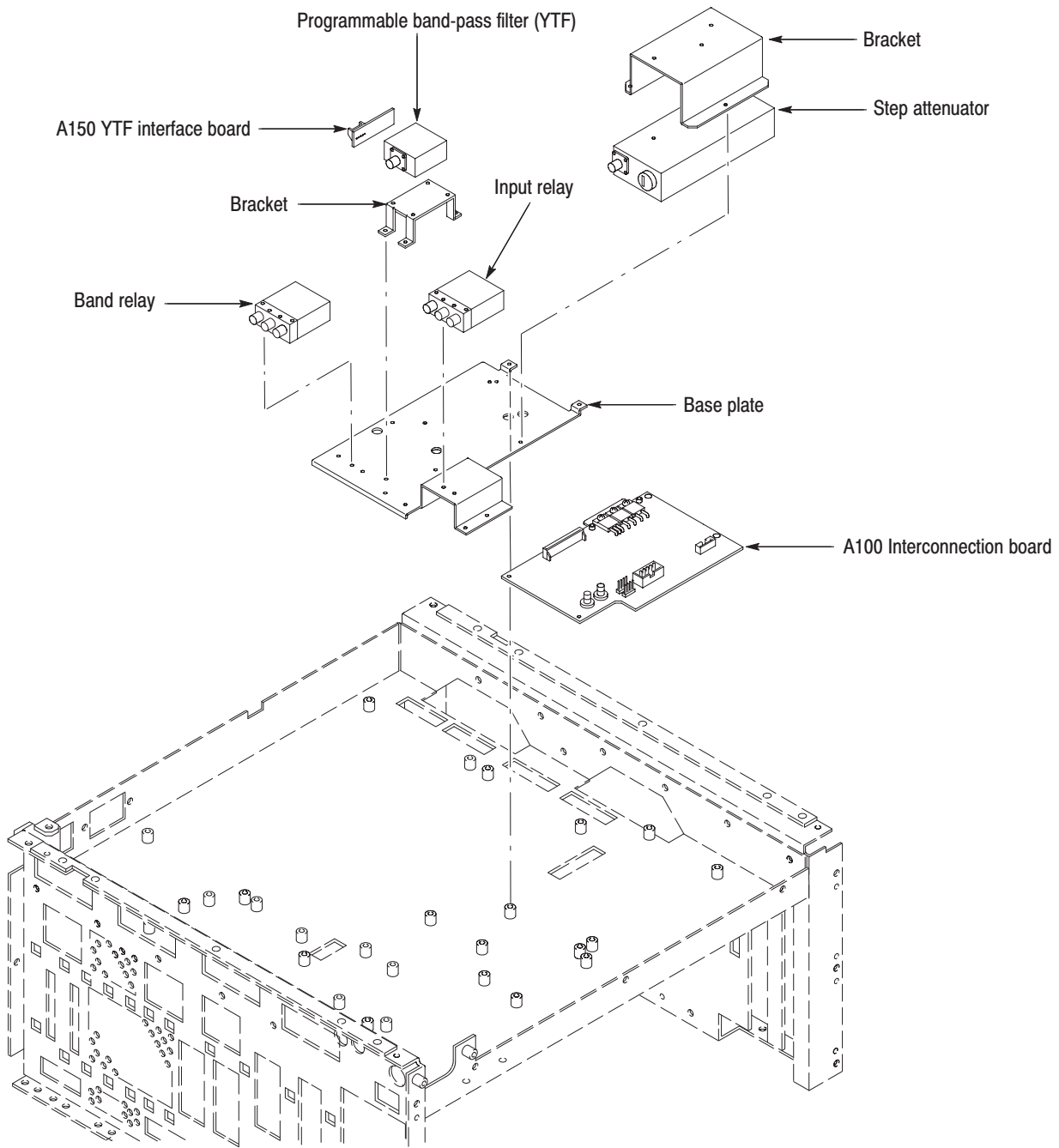

Figure 6-8: Bottom modules - RF1 (RSA2208A)

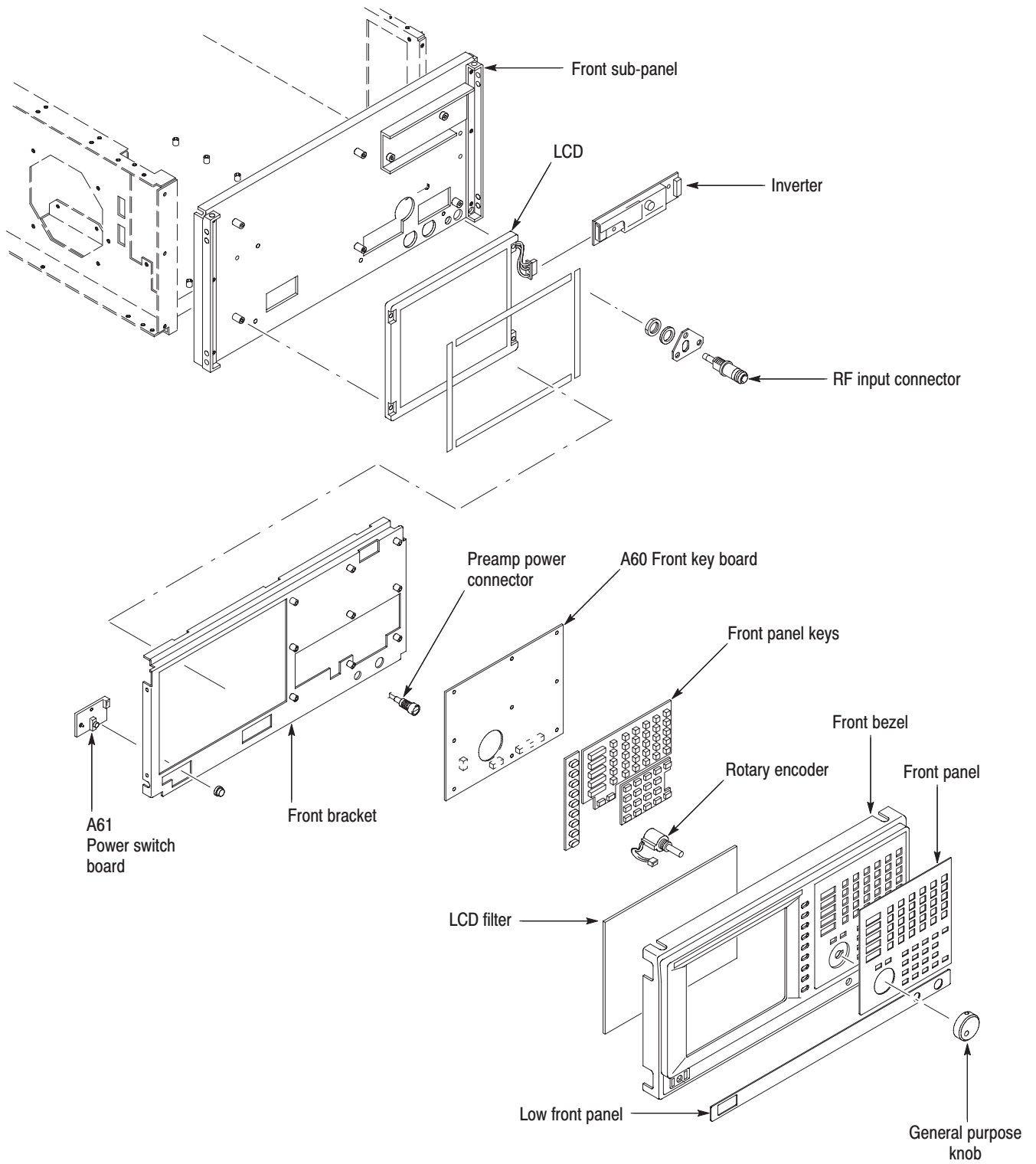

Figure 6-9: Front panel modules

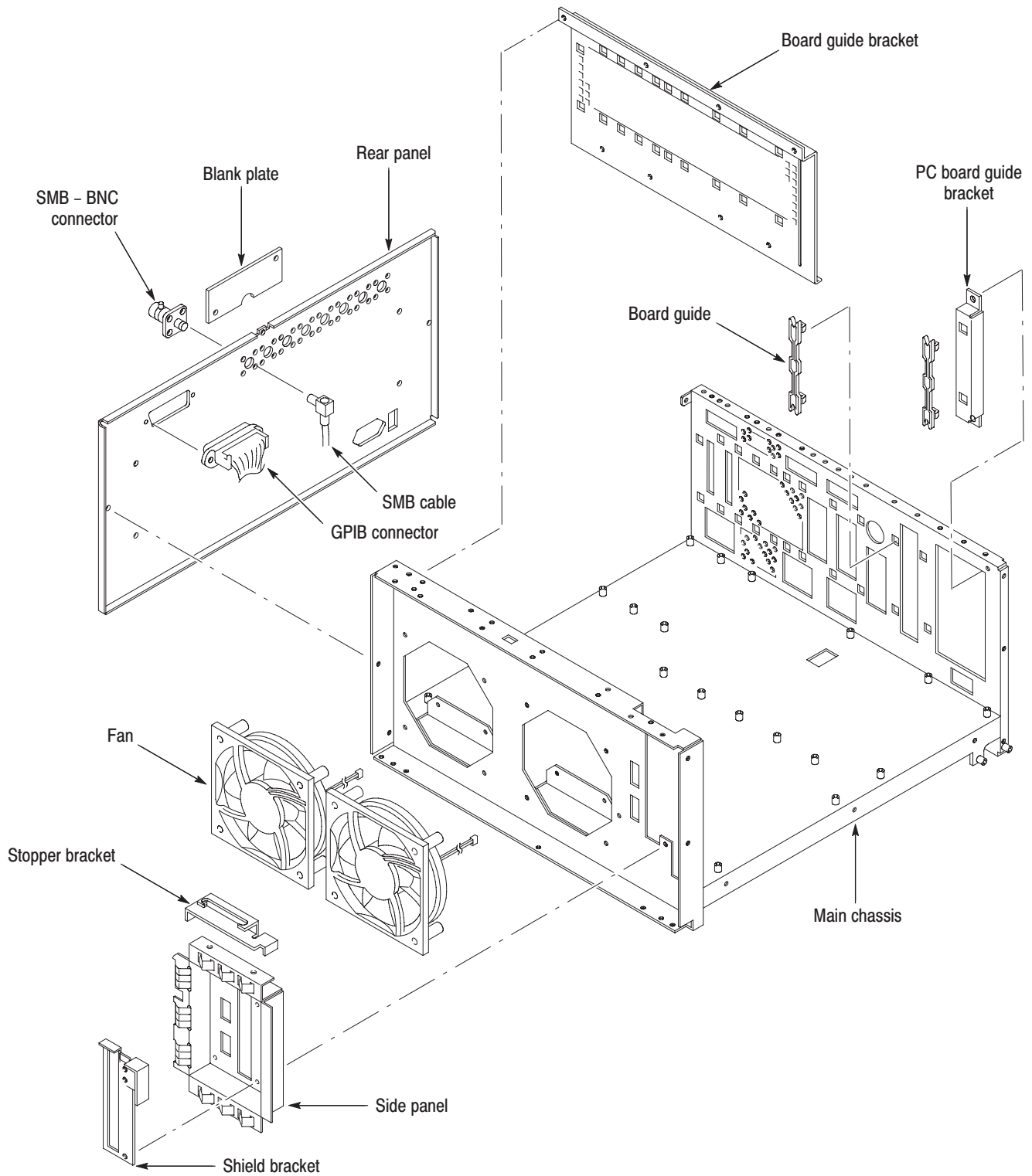

Figure 6-10: Chassis modules

Access Procedure

When you have identified the module to be removed for service, read *General Instructions* found earlier in this section. Then use the flowchart in Figure 6-11 to determine which procedures to use for removing the module. The removal procedures end with reinstallation instructions.

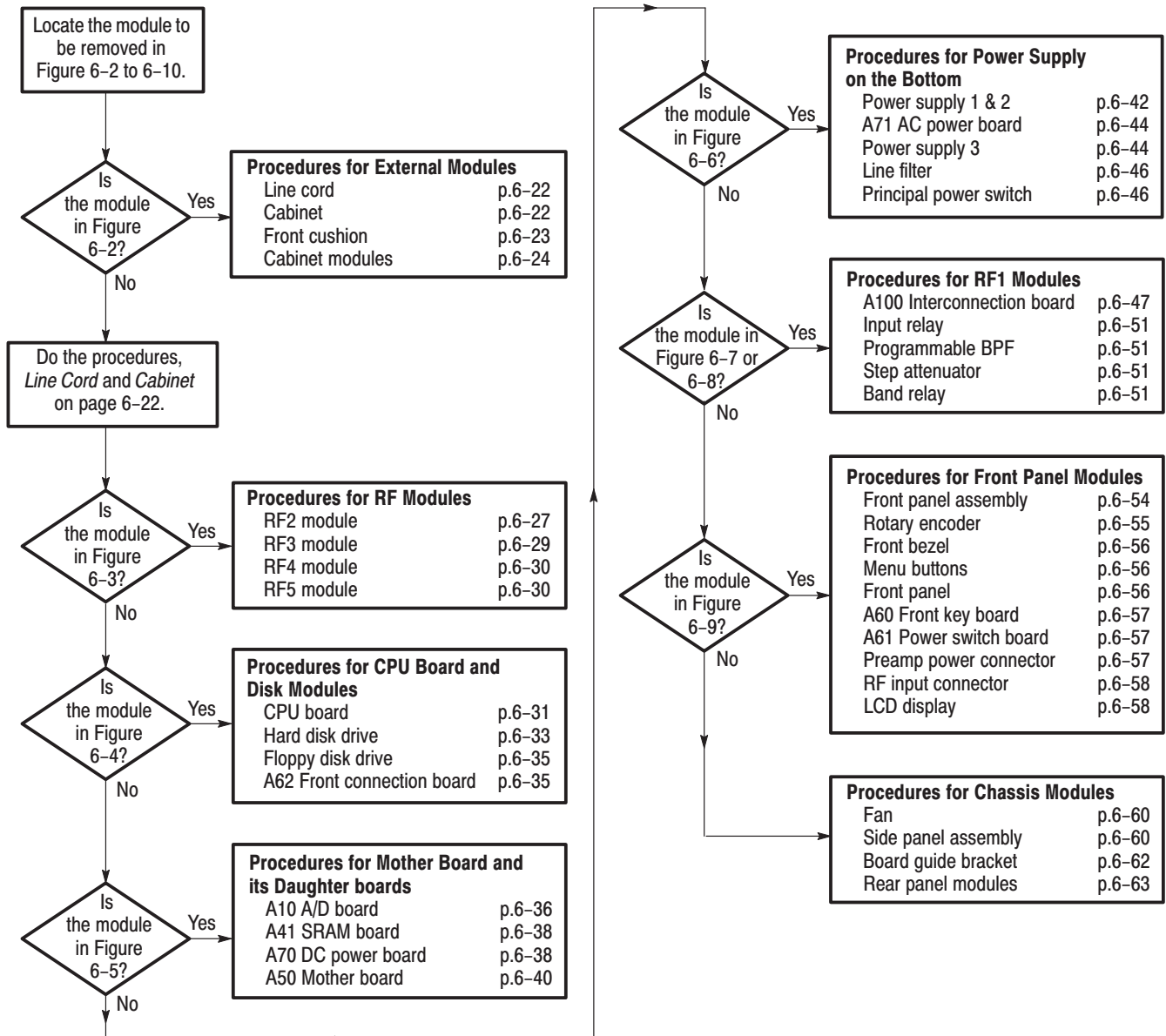

Figure 6-11: Guide to removal procedures

Procedures for External Modules

Read the *Access Procedure* on page 6–21 before proceeding. The procedures are presented in the following order:

- *Line cord*
- *Cabinet*
- *Front cushion*
- *Cabinet modules*

- Line Cord**
1. *Orient the analyzer:* Set the analyzer so its bottom is down on the work surface and its rear is facing you.
 2. *Remove the line cord:* Remove the line cord from the rear cover. See Figure 6–12.
 3. *Reinstallation:* Reverse step 2 to reinstall the line cord.

- Cabinet**
1. *Assemble equipment:* Obtain a #2 Phillips screwdriver (Items 1 and 3).
 2. *Orient the analyzer:* Set the analyzer so its bottom is down on the work surface and the rear panel is facing you.
 3. *Remove the cabinet:* See Figure 6–12.
 - a. Remove the one screw securing the rear foot over the cabinet to the rear panel at each corner.
 - b. Remove the center two screws securing the cabinet to the rear panel.
 - c. Slide the cabinet backward. As you remove the cabinet, take care not to bind or snag it on the analyzer's internal cabling.
 4. *Reinstallation:* Reverse step 3 to reinstall the cabinet.

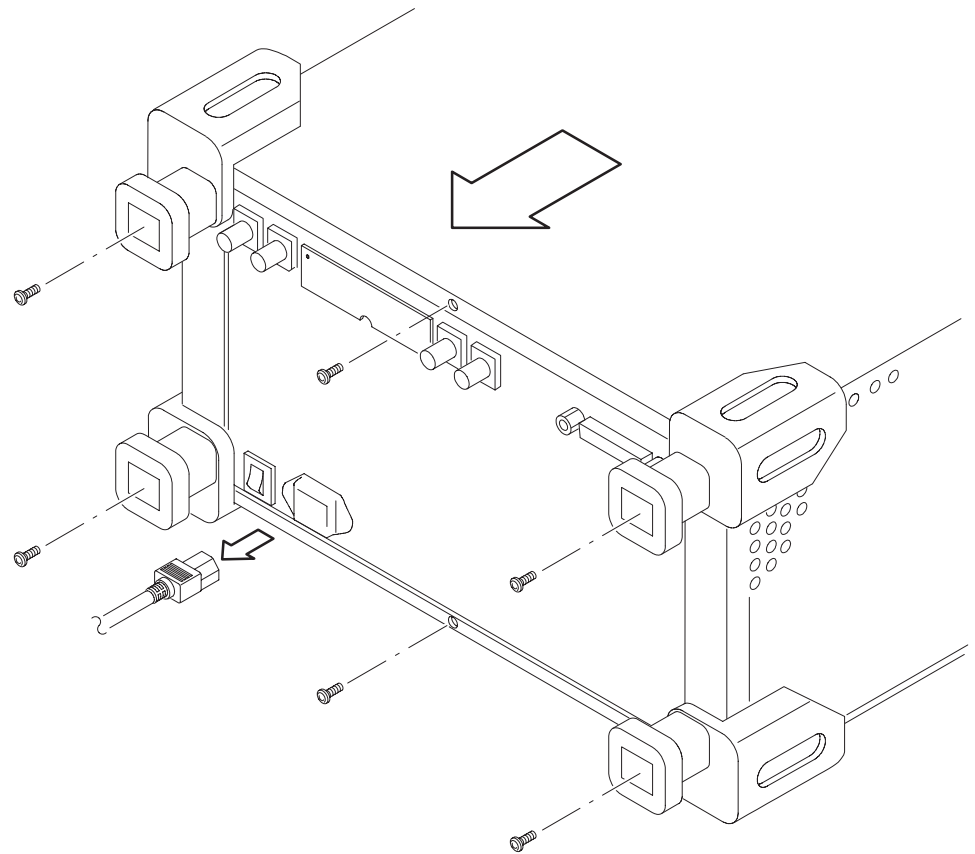

Figure 6-12: Line cord and cabinet removal

Front Cushion

1. *Assemble equipment and locate modules to be removed:*
 - a. You will need a #2 Phillips screwdriver (Items 1 and 3).
 - b. Locate the front cushion in the *External modules* diagram, Figure 6-2.
2. *Orient the analyzer:* Set the analyzer so its bottom is down on the work surface and its front is facing you.
3. *Remove the front cushion:* See Figure 6-13.
 - a. Remove the two screws securing the front cushion to the side panel at each side.
 - b. Lifting the front of the analyzer slightly, move the front cushion away.
4. *Reinstallation:* Reverse step 3 to reinstall the front cushion.

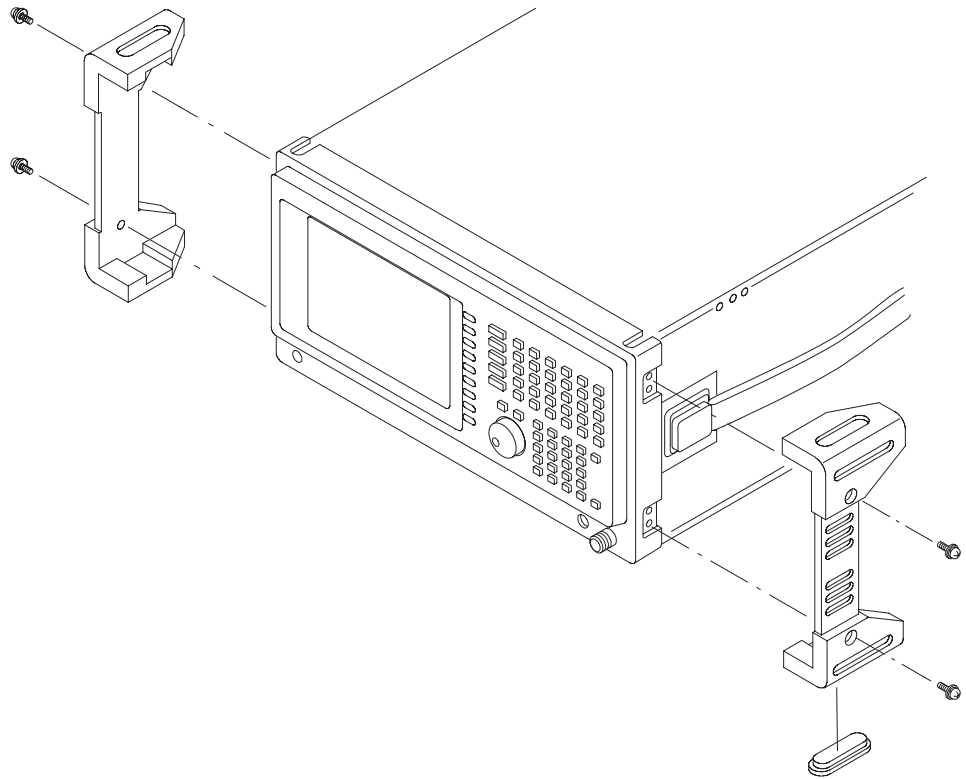

Figure 6-13: Front cushion removal

Cabinet Modules

1. *Assemble equipment and locate modules to be removed:*
 - a. Have a pair of needle-nose pliers handy (Item 12).
 - b. Locate the modules to be removed in the locator diagram *External Modules* (see Figure 6-2).
2. *Orient the analyzer:* Set the analyzer so the left side is down on the work surface and its handle is facing upwards.
3. *Remove the handle:*
 - a. Insert the tips of a pair of needle-nose pliers (Item 12) into the hole of either handle cap. Push and hold to depress the handle release.
 - b. While holding the handle release, pull the handle out of the slot in the handle cap. Repeat the procedure to remove the handle from the other handle cap.
 - c. Reverse the procedure to reinstall.

4. *Remove the handle caps:*
 - a. Insert the retaining ring pliers (Item 13) into the opening created in the handle cap when you removed the handle.
 - b. While using the pliers to expand the handle cap outward, grasp it and snap it away from the cabinet.
 - c. Repeat procedure to remove the remaining cap as needed.
 - d. To reinstall, push the cap(s) back on.
5. *Remove the flip stand:*
 - a. Grasp the flip stand by both sides near where it joins each flip stand foot.
 - b. Compress the flip stand until the flip stand ends clear the flip stand feet.
 - c. To reinstall, compress the flip stand and insert it into the flip stand feet.
6. *Remove the foot:*
 - a. Remove the cabinet (refer to *Cabinet* on page 6–22).
 - b. Working from inside the cabinet, push the two retainers to release the foot you wish to remove and lift it away from the outside of the cabinet.
 - c. Remove as many of the feet as needed.
 - d. To reinstall feet, reinsert the two retainers into their slots in the cabinet and snap into place.
7. *Reinstallation:* If any flip stand feet were removed, reinstall as directed in step 6c; then refer to the *Cabinet* procedure on page 6–22 to reinstall the cabinet. Reverse steps 3 and 5, reversing each step, to reinstall the flip stand, then the handle caps (if removed), then the handle.

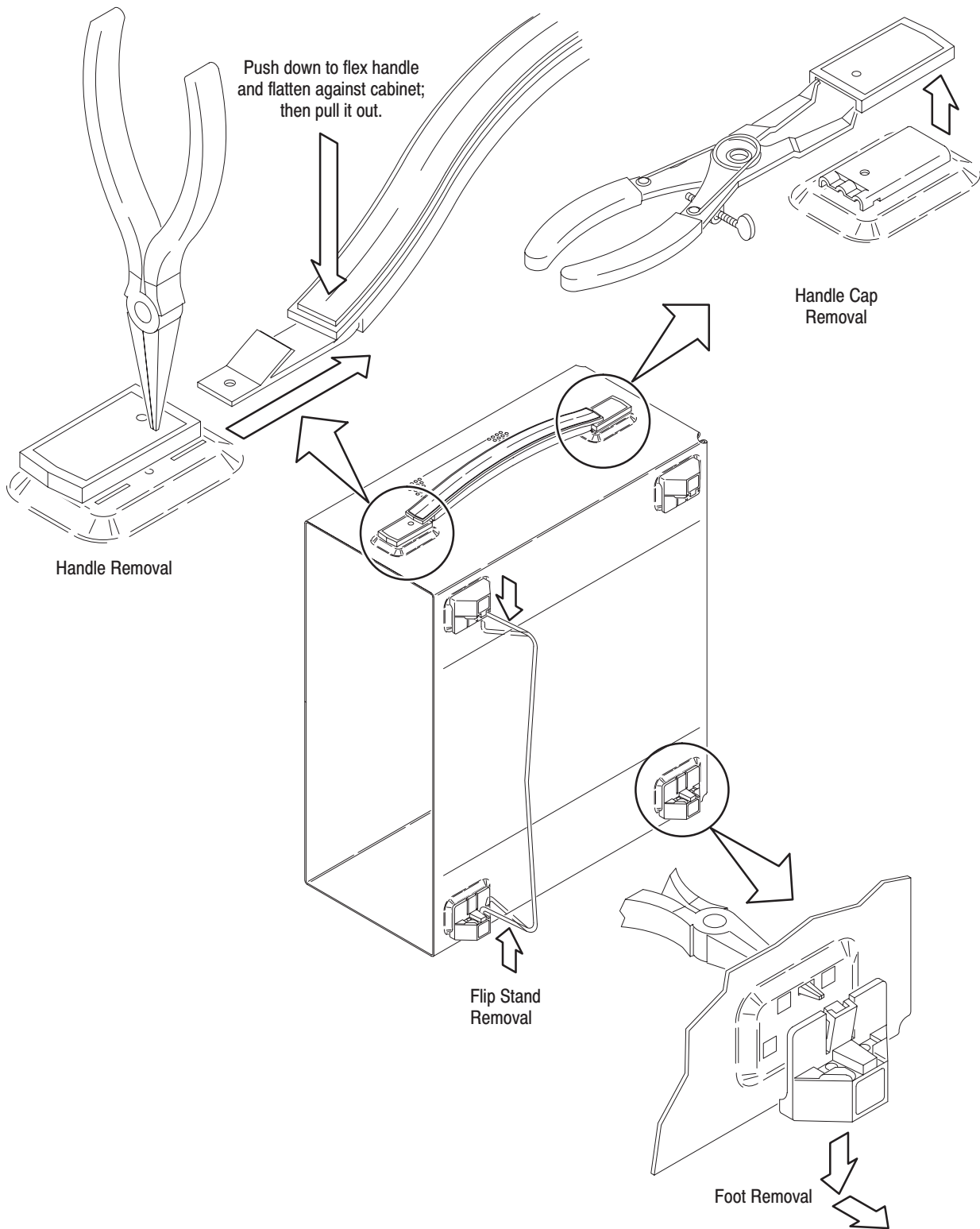

Figure 6-14: Cabinet Modules Removal

Procedures for RF Modules

Read the *Access Procedure* on page 6–21 before proceeding. The procedures are presented in the following order:

- *RF2 module*
- *RF3 module*
- *RF4 module*
- *RF5 module*

RF2 Module

1. *Assemble equipment and locate module to be removed:*
 - a. You will need a #2 Phillips screwdriver (Items 1 and 3) and a $\frac{5}{16}$ inch wrench (Item 11).
 - b. Locate the RF2 module in the locator diagram *RF Modules*, Figure 6–3, page 6–13.
2. *Orient the analyzer:* Set the analyzer so the bottom is down on the work surface and its front is facing you.
3. *Remove the RF2 module:* See Figure 6–15. Also see Figure 6–35 on page 6–73 for the cable interconnection.
 - a. Using a $\frac{5}{16}$ inch wrench, disconnect the SMA cable W201 on the RF2 module.
 - b. Unplug the following SMB cables on the RF2 module: W208, W207, W307, W21, W22, and W23.
 - c. Remove the two screws securing the module to the main chassis. Lift the module up.
4. *Reinstallation:* Reverse step 3 to reinstall the RF2 module.

RF3 Module

1. *Assemble equipment and locate module to be removed:*
 - a. You will need a #2 Phillips screwdriver (Items 1 and 3), an SMA torque driver with a long type bit (Items 5 and 6), and a $\frac{5}{16}$ inch wrench (Item 11).
 - b. Locate the RF3 module in the locator diagram *RF Modules*, Figure 6–3, page 6–13.
2. *Orient the analyzer:* Set the analyzer so the bottom is down on the work surface and its front is facing you.
3. *Remove the RF3 module:* See Figure 6–15. Also see Figure 6–35 on page 6–73 for the cable interconnection.
 - a. Using a $\frac{5}{16}$ inch wrench, disconnect the SMA cable W201 on the RF3 module.
 - b. Using a SMA torque driver with a long type bit (Item 5 and 6), disconnect the SMA cable W109 (RSA2203A) / W124 (RSA2208A) on the RF3 module.
 - c. *RSA2208A only.* Using a $\frac{5}{16}$ inch wrench, disconnect the SMA cable W106 on the RF3 module.
 - d. Unplug the SMB cables W26, W27, and W307 on the RF3 module.
 - e. Unplug the cable W28 on the RF4 module (not on the RF3 as the connector is hard to reach from the top).
 - f. Remove the two screws securing the module to the main chassis. Lift the module up.
4. *Reinstallation:* Reverse step 3 to reinstall the RF3 module.

- RF4 Module**
1. *Assemble equipment and locate module to be removed:*
 - a. You will need a #2 Phillips screwdriver.
 - b. Locate the RF4 module in the locator diagram *RF Modules*, Figure 6–3, page 6–13.
 2. *Orient the analyzer:* Set the analyzer so the bottom is down on the work surface and its front is facing you.
 3. *Remove the RF4 module:* See Figure 6–15. Also see Figure 6–35 on page 6–73 for the cable interconnection.
 - a. Unplug the following SMB cables on the RF4 module: W27, W23, W26, W13, W21, W32, W22, and W29.
 - b. Unplug the cable W28 on the RF4 module.
 - c. Remove the two screws securing the module to the main chassis. Lift the module up.
 4. *Reinstallation:* Reverse step 3 to reinstall the RF4 module.

- RF5 Module**
1. *Assemble equipment and locate module to be removed:*
 - a. You will need a #2 Phillips screwdriver.
 - b. Locate the RF5 module in the locator diagram *RF Modules*, Figure 6–3, page 6–13.
 2. *Orient the analyzer:* Set the analyzer so the bottom is down on the work surface and its front is facing you.
 3. *Remove the RF5 module:* See Figure 6–15. Also see Figure 6–35 on page 6–73 for the cable interconnection.
 - a. Unplug the following SMB cables on the RF5 module: W207, W31, W30, W29, W208, W32, W41, and W40.
 - b. Remove the two screws securing the module to the main chassis. Lift the module up.
 4. *Reinstallation:* Reverse step 3 to reinstall the RF5 module.

Procedures for CPU Board and Disk Modules

Read the *Access Procedure* on page 6–21 before proceeding. The procedures are presented in the following order:

- *CPU board*
- *Hard disk drive*
- *Floppy disk drive*
- *A62 Front connection board*

CPU Board

1. *Assemble equipment and locate module to be removed:*
 - a. You will need a #2 Phillips screwdriver (Items 1 and 3).
 - b. Locate the CPU board in the *CPU board and disk modules* diagram, Figure 6–4, page 6–14.
2. *Orient the analyzer:* Set the analyzer so its bottom is down on the work surface and its front is facing you.
3. *Remove the brackets:* See Figure 6–16.
 - a. Remove the two screw securing the board stopper bracket to the memory support bracket. Lift the bracket away.
 - b. Remove the two screw securing the memory support bracket to the disk bracket. Lift the bracket away.
4. *Remove the CPU board:*
 - a. Unplug the cables from the connector FDD1, COM1, IDE1, USB, CN2, and CN3 on the CPU board.
 - b. Unplug the cable from the connector J102 on the A63 DVO converter attached to the CPU board.
 - c. Remove the two screw securing the board to the main chassis. Lift the board up away.
5. *Reinstallation:* Reverse step 3 and 4 to reinstall the CPU board.

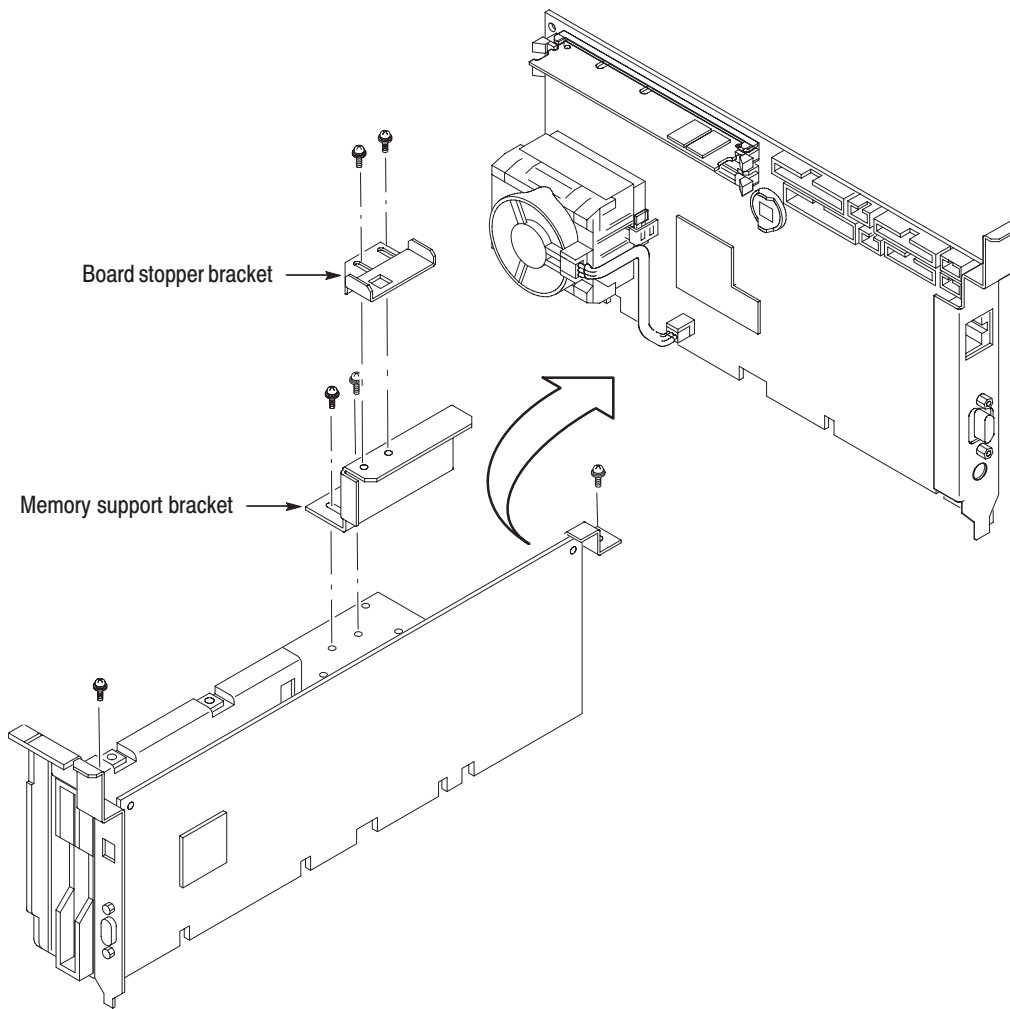
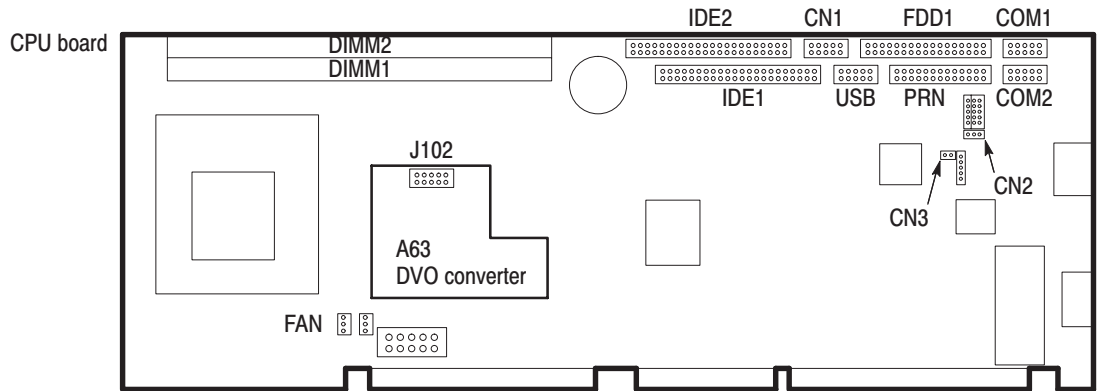

Figure 6-16: CPU board removal

Hard Disk Drive**1. Back up the user files:**

Use the Windows Back Up tool to back up files stored on the hard disk. The Back Up tool is located in the System Tools folder in the Accessories folder. Start the tool and determine which files and folders to back up. Use the Windows on-line help for information on using the Back Up tool.

For the analyzer, the user-generated files consist of these four types of files, which have these extensions:

- .STA (Status file)
- .IQT (Data file)
- .TRC (Trace file)
- .COR (Amplitude correction file)

2. Assemble equipment and locate module to be removed:

- a. You will need a #2 Phillips screwdriver (Items 1 and 3).
- b. Locate the hard disk drive in the *CPU board and disk modules* diagram, Figure 6-4, page 6-14.

3. Orient the analyzer: Set the analyzer so its bottom is down on the work surface and its left side is facing you.**4. Remove the disk bracket:** See Figure 6-17.

- a. Remove the two screws securing the disk bracket to the shield bracket.
- b. Remove the two screws securing the disk bracket to the main chassis.
- c. Lift up the disk bracket containing the hard disk drive and the floppy disk drive.

5. Remove the hard disk drive:

- a. Remove the four screws securing the hard disk drive to the disk bracket.
- b. Lift the hard disk drive up away.

6. Reinstallation: Reverse step 4 and 5 to reinstall the hard disk drive.

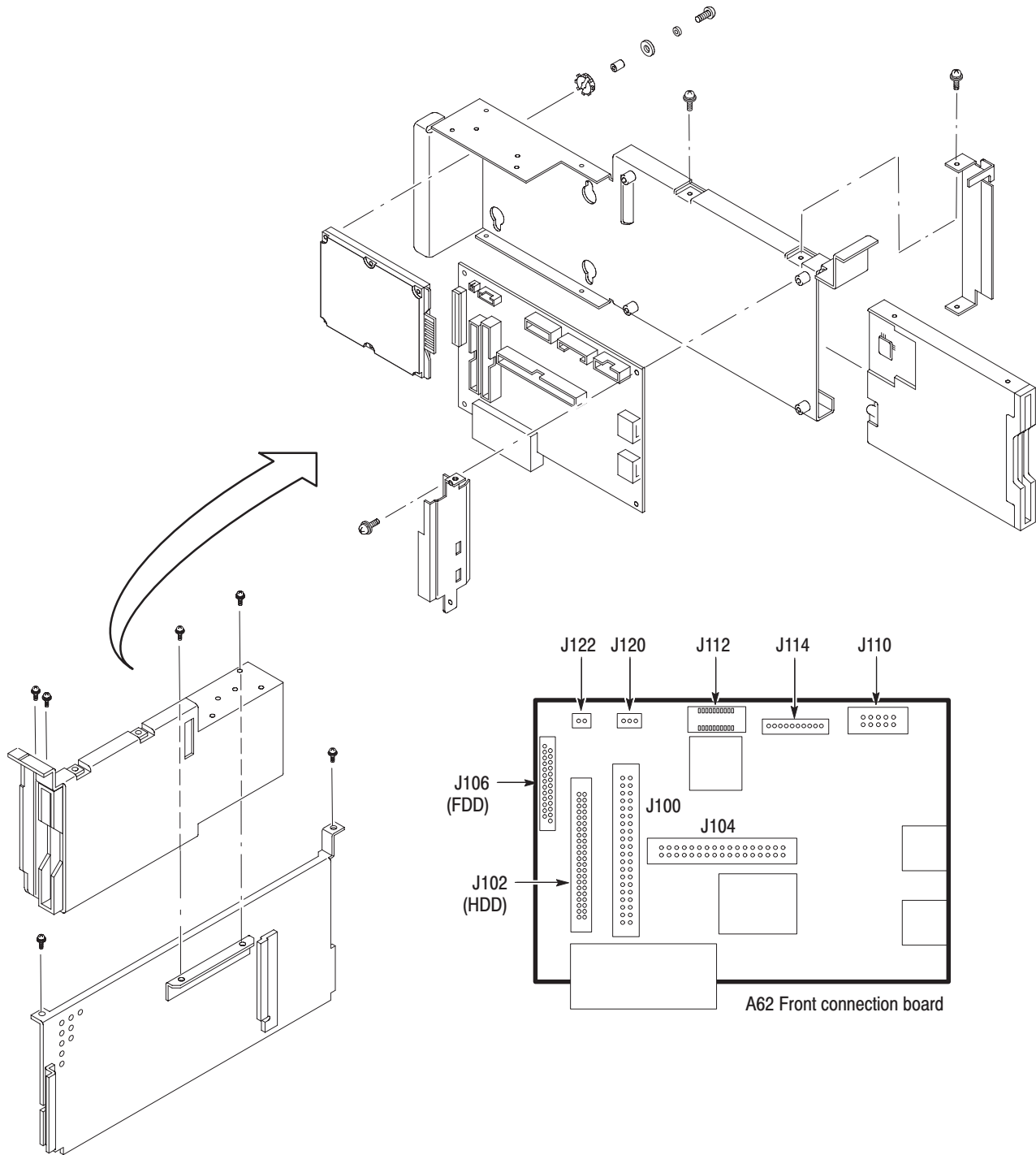

Figure 6-17: Disk module removal

Floppy Disk Drive

1. *Assemble equipment and locate module to be removed:*
 - a. You will need a screwdriver with size Phillips #1 and #2 tips (Items 1, 2, and 3).
 - b. Locate the floppy disk drive in the *CPU board and disk modules* diagram, Figure 6-4, page 6-14.
2. Remove the disk bracket containing the floppy disk drive using step 4 in the hard disk drive removal procedure on page 6-33.
3. *Remove the floppy disk drive:* See Figure 6-17.
 - a. Unplug the floppy driver connector (ribbon interconnect cable) that connects the disk drive to J106 on the A62 Front connection board.
 - b. Using a screwdriver with size Phillips #1 tip, remove the four screws securing the disk drive to the bracket. Pull out the disk drive.
4. *Reinstallation:* Reverse steps 2 and 3 to reinstall the floppy disk drive.

A62 Front Connection Board

1. *Assemble equipment and locate module to be removed:*
 - a. You will need a #2 Phillips screwdriver (Items 1 and 3).
 - b. Locate the A62 Front connection board in the *CPU board and disk modules* diagram, Figure 6-4, page 6-14.
2. Remove the disk bracket containing the A62 Front connection board using step 4 in the hard disk removal procedure on page 6-33.
3. *Remove the A62 Front connection board:* See Figure 6-17.
 - a. Remove the two screws securing the shield bracket over the A62 board to the disk bracket.
 - b. Remove the two screws securing the A62 board to the disk bracket. Lift the board up away.
4. *Reinstallation:* Reverse steps 2 and 3 to reinstall the A62 board.

Procedures for Mother Board and its Daughter Boards

Read the *Access Procedure* on page 6–21 before proceeding. The procedures are presented in the following order:

- *A10 A/D board*
- *A41 SRAM board*
- *A70 DC power board*
- *A50 Mother board*

A10 A/D Board

1. *Assemble equipment and locate module to be removed:*
 - a. You will need a #2 Phillips screwdriver (Items 1 and 3).
 - b. Locate the A10 A/D board in locator diagram *Mother board and its daughter boards*, Figure 6–5, page 6–15.
2. *Orient the analyzer:* Set the analyzer so its bottom is down on the work surface and its front is facing you.
3. *Remove the board support bracket:* See Figure 6–19 on page 6–39. Remove the two screws securing the board support bracket to the rear support bracket and the RF5 module. Lift the board support bracket away.
4. *Remove the A10 A/D board:* See Figure 6–18. Also see Figure 6–35 on page 6–73 for the cable interconnection.
 - a. Unplug the SMB cable W30 and W31.
 - b. *Option 05 only.* Unplug the SMB cable W25.
 - c. Remove the two screws securing the shield bracket to the main chassis.
 - d. Lift up the the A10 board with the brackets.
5. *Remove the shield brackets:* Remove the five screws securing the front shield bracket to the A10 board. Lift the front shield bracket away.
6. *Reinstallation:* Reverse steps 4 and 5 to reinstall the A10 board and interconnect cables.

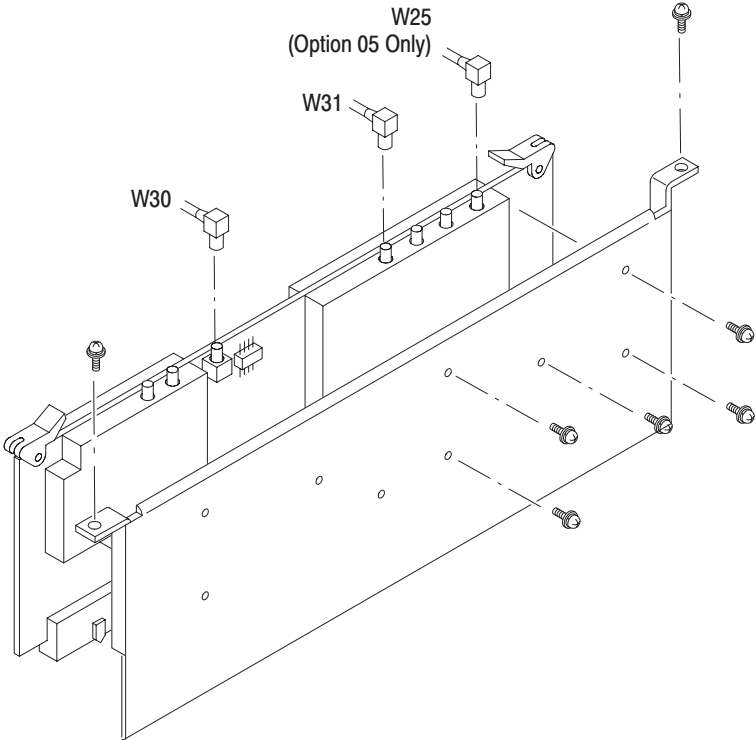

Figure 6-18: A10 A/D board removal

A41 SRAM Board

1. *Assemble equipment and locate module to be removed:*
 - a. You will need a #2 Phillips screwdriver (Items 1 and 3).
 - b. Locate the A41 SRAM board in locator diagram *Mother board and its daughter boards*, Figure 6–5, page 6–15.
 - c. Do step 3 in the *A10 A/D Board* procedure on page 6–36 to remove the board support bracket.
2. *Orient the analyzer:* Set the analyzer so its bottom is down on the work surface and its front is facing you.
3. *Remove the A41 SRAM board:* See Figure 6–19. Also see Figure 6–35 on page 6–73 for the cable interconnection.
 - a. Unplug the SMB cable W46 (TRIG OUT) and W47 (TRIG IN).
 - b. Lift up the the A41 board.
4. *Reinstallation:* Reverse step 3 to reinstall the A41 board and interconnect cables.

A70 DC Power Board

1. *Assemble equipment and locate module to be removed:*
 - a. You will need a #2 Phillips screwdriver (Items 1 and 3).
 - b. Locate the A70 DC power board in locator diagram *Mother board and its daughter boards*, Figure 6–5, page 6–15.
 - c. Do step 3 in the *A10 A/D Board* procedure on page 6–36 to remove the board support bracket.
2. *Orient the analyzer:* Set the analyzer so its bottom is down on the work surface and its front is facing you.
3. *Remove the rear support bracket:* See Figure 6–19.
 - a. Remove the two screws securing the bracket to the A70 board.
 - b. Remove the four screws securing the bracket to the main chassis.
 - c. Lift the bracket away.
4. *Remove the A70 DC power board:* See Figure 6–19.
 - a. Unplug the fan power cable from J300 and J302.
 - b. Unplug the cable W75 (GPIB) from J410.
 - c. Lift up the A70 board.

5. *Reinstallation:* Reverse step 3 to reinstall the A70 board and interconnect cables.

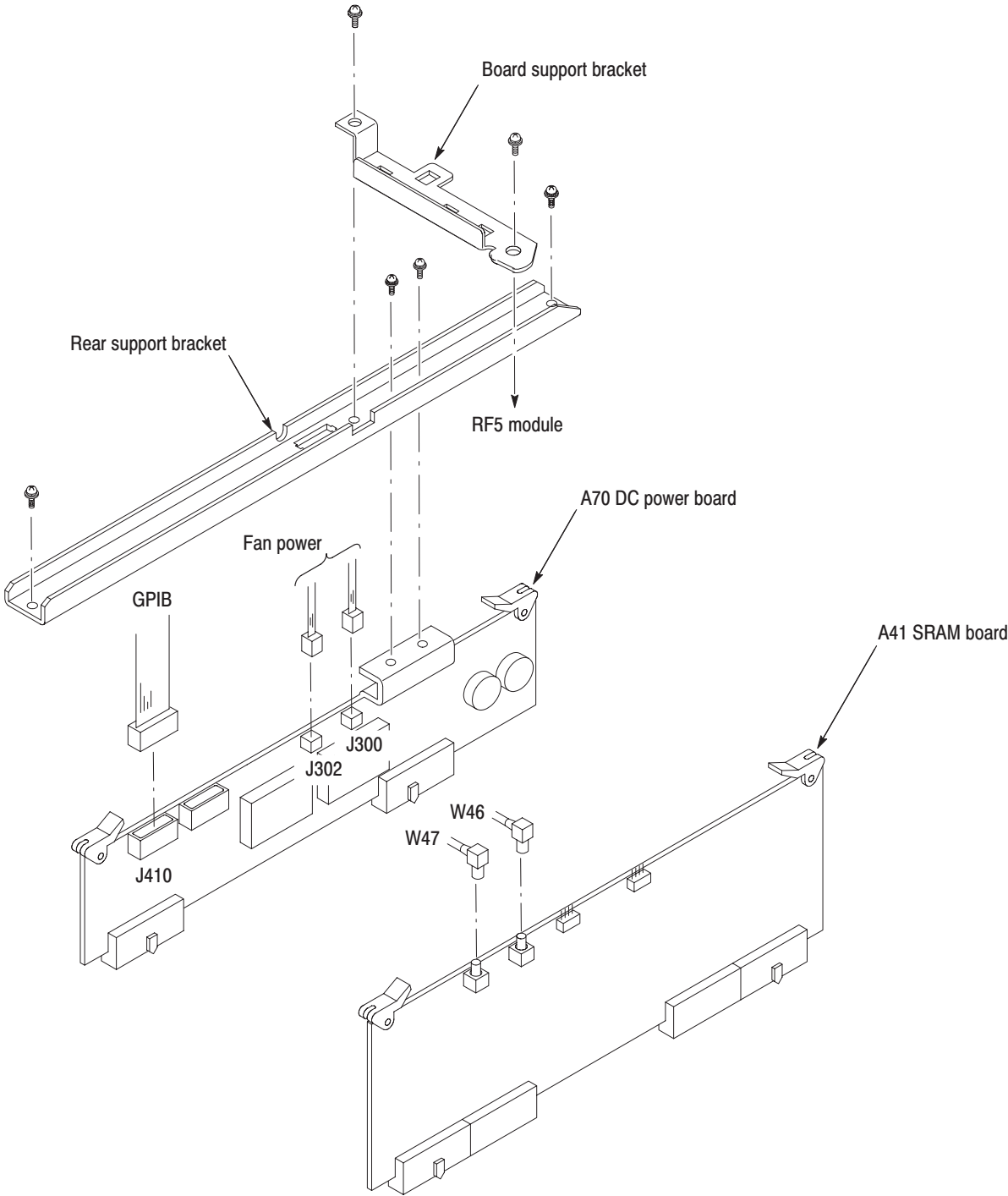

Figure 6-19: Daughter boards removal

A50 Mother Board

1. *Assemble equipment and locate module to be removed:*
 - a. You will need a #2 Phillips screwdriver (Items 1 and 3).
 - b. Locate the A50 Mother board in locator diagram *Mother board and its daughter boards*, Figure 6–5, page 6–15.
 - c. Remove the RF modules (Refer to the *RF Modules* procedure on page 6–27).
 - d. Remove the daughter boards (Refer to the procedure *A10 Board through A70 DC Power Board* starting on page 6–36).
2. *Remove the A50 Mother board:*
 - a. *Orient the analyzer:* Set the analyzer so its top is down on the work surface and its front is facing you.
 - b. Unplug the cables at J902, J900, J901, J912, J910, J911, J100, and J920 on the bottom of the analyzer. See Figure 6–36 on page 6–74 (RSA2203A) or Figure 6–37 on page 6–75 (RSA2208A) for cable interconnection.
 - c. *Orient the analyzer:* Set the analyzer so its bottom is down on the work surface and its rear is facing you.
 - d. Remove 25 screws securing the A50 board to the main chassis.
 - e. Pull the board backward until you can unplug the cables at J700, J810, J60, and J710 on the A50 board. See Figure 6–35 on page 6–73 for cable interconnection.
 - f. Lift up and remove the board.
3. *Reinstallation:*
 - a. Reverse step 2 to reinstall the A50 board.
 - b. Reinstall the daughter boards. Refer to *A10 Board through A70 DC Power Board* starting on page 6–36.
 - c. Reinstall the RF modules. Refer to *RF Modules* on page 6–27.

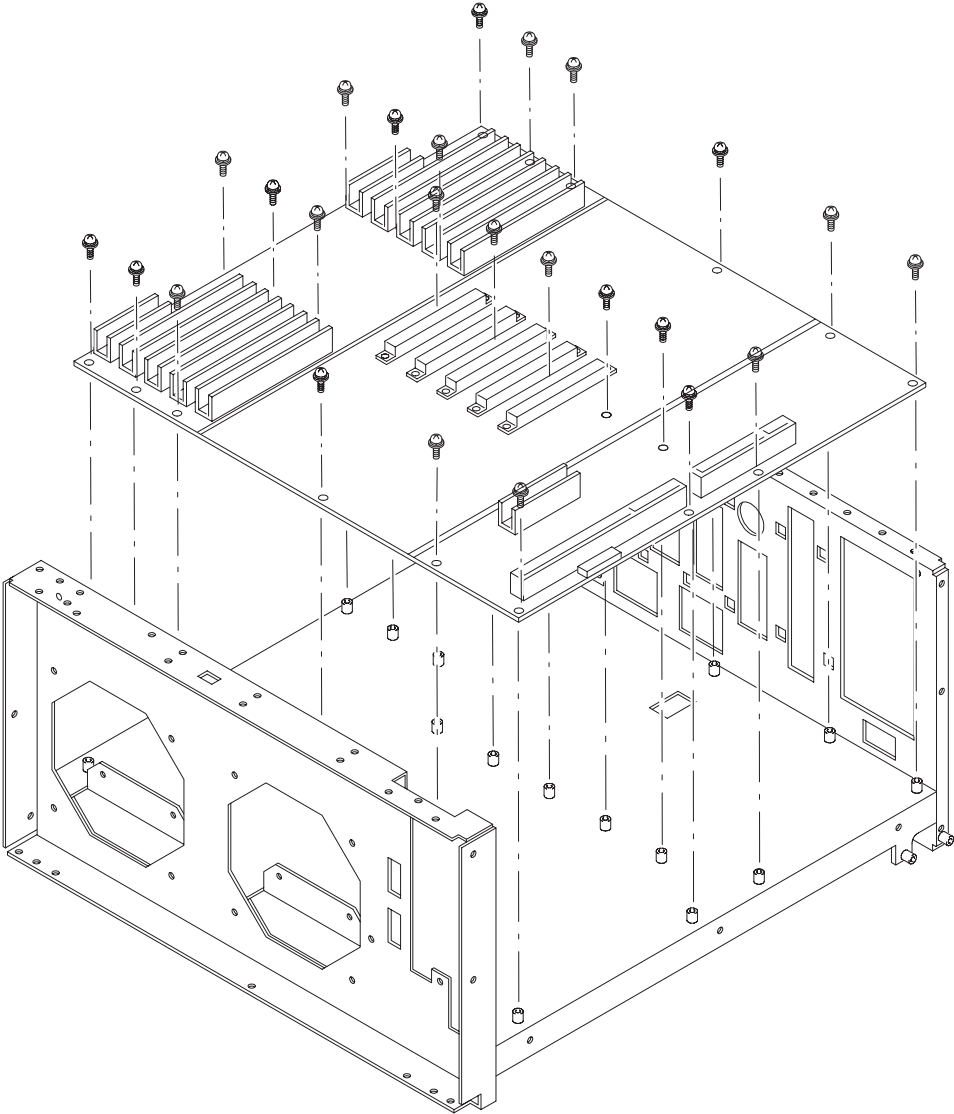

Figure 6-20: Mother board removal

Procedures for Power Supply Modules on the Instrument Bottom

Read the *Access Procedure* on page 6–21 before proceeding. The procedures are presented in the following order:

- *Power supply 1 and 2*
- *A71 AC power board*
- *Power supply 3 (standby power)*
- *Line filter*
- *Principal power switch*

Power Supply 1 and 2

1. *Assemble equipment and locate module to be removed:*
 - a. You will need a #2 Phillips screwdriver (Items 1 and 3).
 - b. Locate the power supply 1 and 2 in the locator diagram *Bottom modules – Power supply*, Figure 6–6, page 6–16.
2. *Orient the analyzer:* Set the analyzer so its top is down on the work surface and its front is facing you.
3. *Remove the power supply 1:* See Figure 6–22. Also see Figure 6–36 (RSA2203A) or 6–37 (RSA2208A) for cable interconnection.
 - a. Unplug the cables at J902, J900, and J901 on the A50 Mother board.
 - b. Unplug the cable at J110 on the A71 AC power board.
 - c. Remove the four screws securing the power supply 1 to the bracket. Lift up and remove the power supply 1.
4. *Remove the power supply 2:* See Figure 6–22. Also see Figure 6–36 (RSA2203A) or 6–37 (RSA2208A) for cable interconnection.
 - a. Unplug the cables at J912, J910, and J911 on the A50 Mother board.
 - b. Unplug the cable at J130 on the A71 AC power board.
 - c. Remove the four screws securing the power supply 2 to the bracket. Lift up and remove the power supply 2.
5. *Reinstallation:* Reverse steps 3 and 4 to reinstall the power supply 1 and 2.

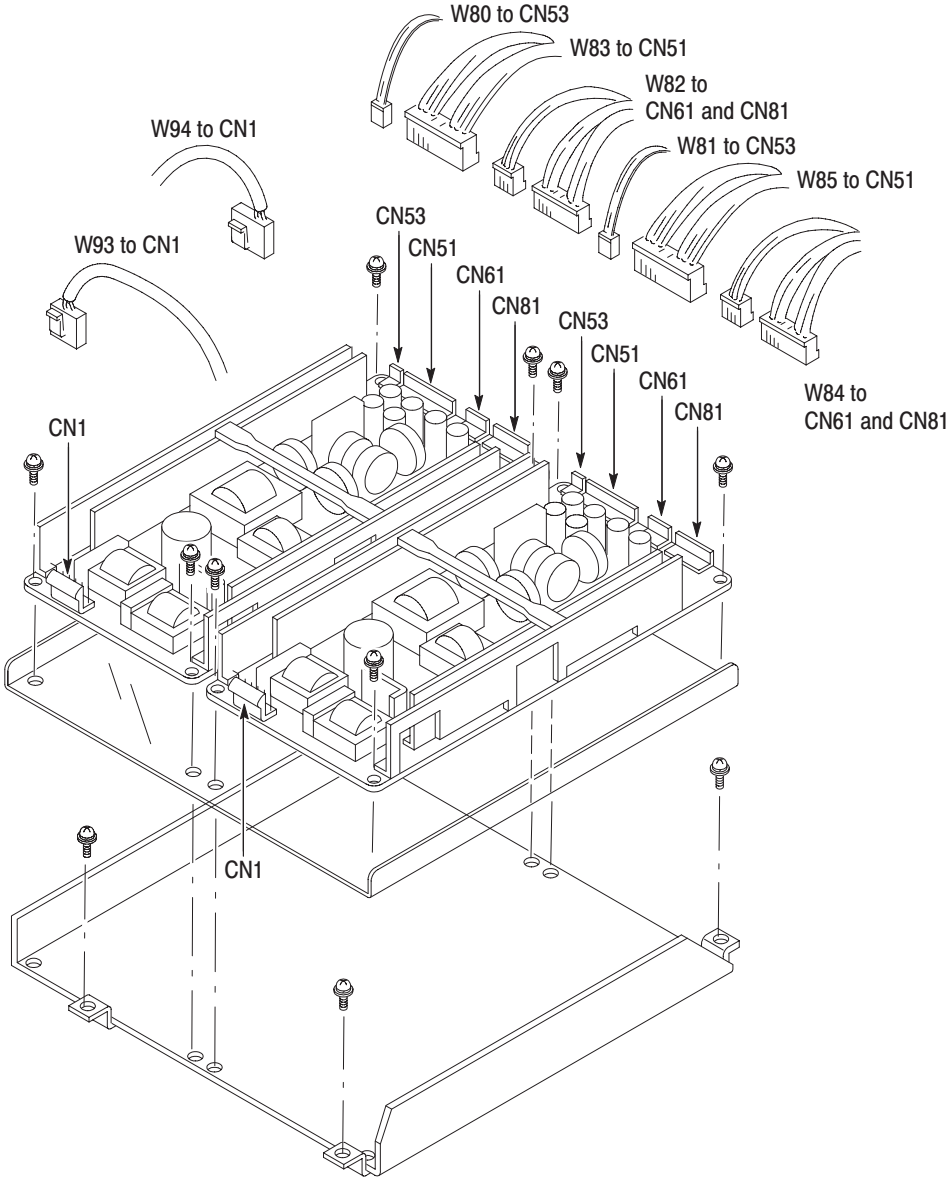

Figure 6-21: Power supply 1 and 2 removal

A71 AC Power Board

1. *Assemble equipment and locate module to be removed:*
 - a. You will need a #2 Phillips screwdriver (Items 1 and 3).
 - b. Locate the A71 AC power board in the locator diagram *Bottom modules – Power supply*, Figure 6–6, page 6–16.
2. *Orient the analyzer:* Set the analyzer so its top is down on the work surface and its front side is facing you.
3. *Remove the A71 AC power board:* See Figure 6–22. Also see Figure 6–36 (RSA2203A) or 6–37 (RSA2208A) for cable interconnection.
 - a. Unplug the cables at J100, J110, J120, and J130 on the A71 board.
 - b. Remove the four screws securing the A71 board to the main chassis. Lift up the board away.
4. *Reinstallation:* Reverse step 3 to reinstall the A71 board.

Power Supply 3

1. *Assemble equipment and locate module to be removed:*
 - a. You will need a #2 Phillips screwdriver (Items 1 and 3).
 - b. Locate the power supply 3 (standby power) in the locator diagram *Bottom modules – Power supply*, Figure 6–6, page 6–16.
2. *Orient the analyzer:* Set the analyzer so its top is down on the work surface and its front side is facing you.
3. *Remove the power supply 3:* See Figure 6–22. Also see Figure 6–36 (RSA2203A) or 6–37 (RSA2208A) for cable interconnection.
 - a. Unplug the cables at CN1 and CN2 on the power supply 3 board.
 - b. Remove the four screws securing the board to the main chassis. Lift up the board away.
4. *Reinstallation:* Reverse step 3 to reinstall the power supply 3.

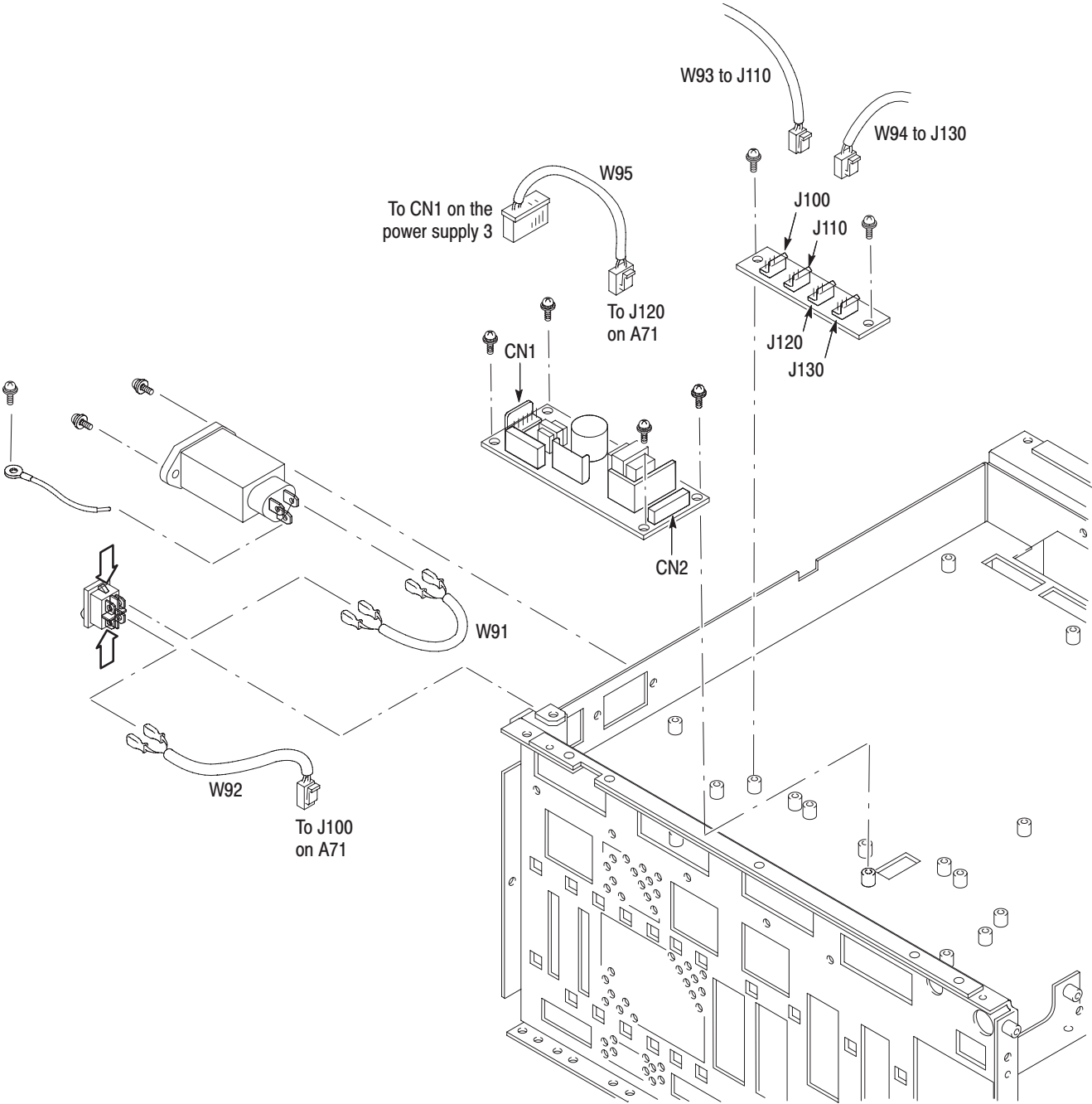

Figure 6-22: Power supply modules removal

Line Filter

1. *Assemble equipment and locate module to be removed:*
 - a. Have a screwdriver with a size Phillips #1 and #2 tip handy (Items 1, 2, and 3).
 - b. Locate the line filter in the locator diagram *Bottom modules – Power supply*, Figure 6–6, page 6–16.
2. *Orient the analyzer:* Set the analyzer so its top is down on the work surface and its rear is facing you.
3. *Remove the line filter:* See Figure 6–22.
 - a. Unplug the cable W92 from the line filter.
 - b. Using a screwdriver with a size Phillips #1 tip, unscrew the one nut that secures the ground lead to the rear chassis.
 - c. Using a screwdriver with a size Phillips #2 tip, remove the two screws securing the line filter to the rear chassis. Remove the line filter.
4. *Reinstallation:* Reverse step 3 to reinstall the line filter.

Principal Power Switch

1. *Assemble equipment and locate module to be removed:* No tools are needed. Locate the principal power switch in the locator diagram *Bottom modules – Power supply*, Figure 6–6, page 6–16.
2. *Orient the analyzer:* Set the analyzer so its top is down on the work surface and its right side is facing you.
3. *Remove the principal power switch:* See Figure 6–22.
 - a. Unplug the cables from the principal power switch.
 - b. Pressing the catches at the top and the bottom of the switch, pull the switch out.
4. *Reinstallation:* Reverse step 3 to reinstall the principal power switch.

Procedures for RF1 Modules on the Instrument Bottom

Read the *Access Procedure* on page 6–21 before proceeding. The procedures are presented in the following order:

- *A100 Interconnection board*
- *Input relay and step attenuator (for RSA2203A)*
- *Input relay, programmable band-pass filter (YTF), step attenuator, and band relay (for RSA2208A)*

A100 Interconnection Board

1. *Assemble equipment and locate module to be removed:*
 - a. You will need a #1 Phillips screwdriver (Items 1 and 2).
 - b. Locate the A100 Interconnection board in the locator diagram *Bottom modules – RF1*, Figure 6–8, page 6–18.
2. *Orient the analyzer:* Set the analyzer so its top is down on the work surface and its left side is facing you.
3. *Remove the A100 Interconnection board:* See Figure 6–23. Also see Figure 6–36 (RSA2203A) or 6–37 (RSA2208A) for cable interconnection.
 - a. Unplug the cable at J100 on the A100 board.
 - b. Do one of the following steps depending your instrument:
 - *For RSA2203A.* Unplug the cables at J120, J230, and J130 on the A100 board.
 - *For RSA2208A.* Unplug the cables at J111, J120, J110, J130, and J280 on the A100 board.
 - c. Unplug the SMB cables at J300 and J302 on the A100 board.
 - d. Remove the two screws securing the base plate through the A100 board to the main chassis.
 - e. Remove the two screws securing the A100 board to the main chassis. Lift the board up away.
4. *Reinstallation:* Reverse step 3 to reinstall the A100 board.

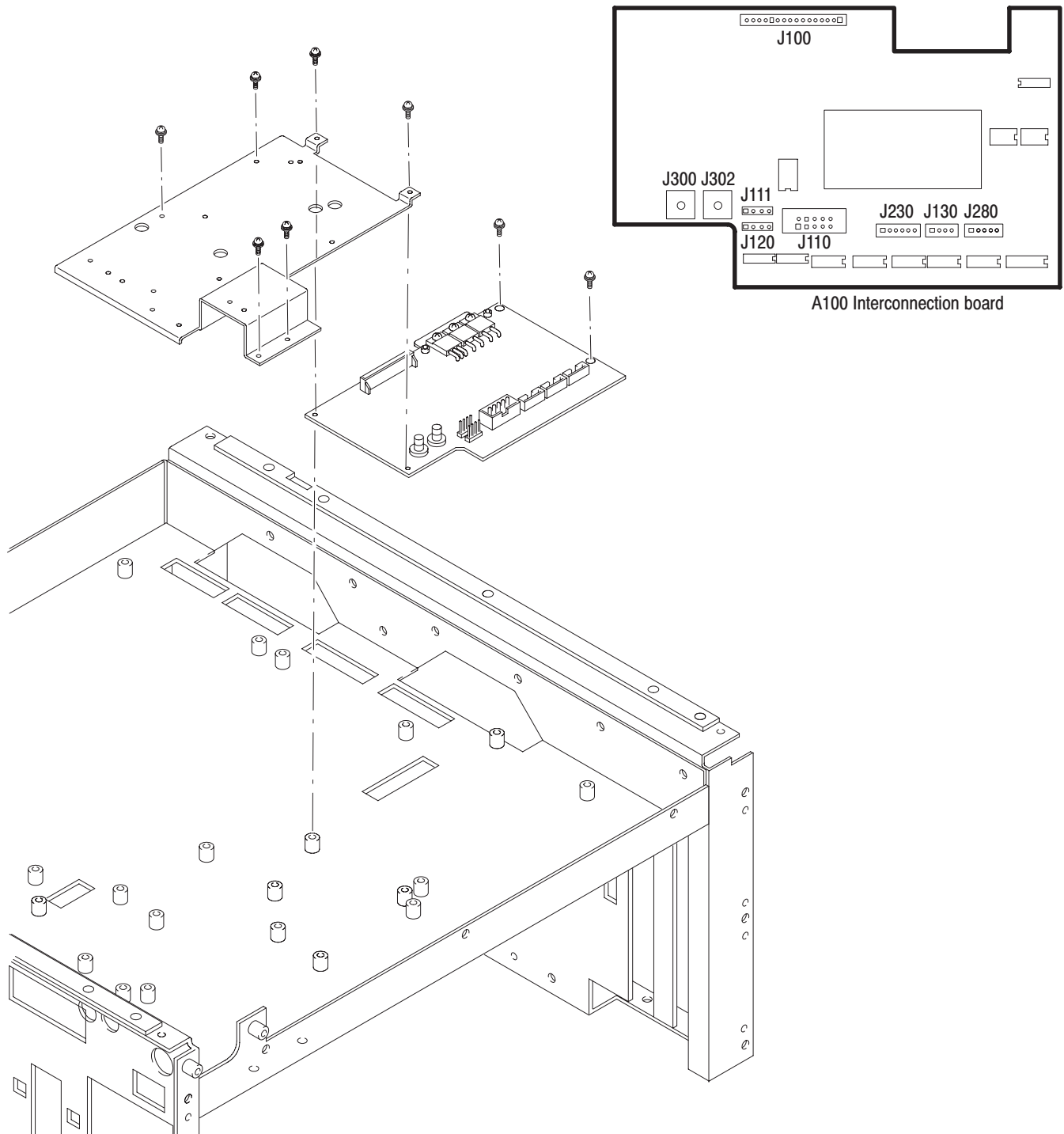

Figure 6-23: RF1 modules removal - 1

**Input Relay and
Step Attenuator
(for RSA2203A)**

1. *Assemble equipment and locate module to be removed:*
 - a. You will need a #1 Phillips screwdriver (Items 1 and 2) and a $\frac{5}{16}$ inch wrench (Item 11).
 - b. Locate the modules in the locator diagram *Bottom modules – RF1*, Figure 6–7, page 6–17.
2. *Orient the analyzer:* Set the analyzer so its top is down on the work surface and its front is facing you.

See Figure 6–24 for the following steps 3 through 4. Also see Figure 6–36 for cable interconnection.

3. *Remove the step attenuator:*
 - a. Using a $\frac{5}{16}$ inch wrench, disconnect the SMA cable W113 on the step attenuator.
 - b. Unplug the cable W116 on the step attenuator.
 - c. Remove the four screws securing the attenuator to the main chassis.
 - d. Using a $\frac{5}{16}$ inch wrench, disconnect the SMA cable W109 on the attenuator.
4. *Remove the input relay:*
 - a. Unplug the cable W114 on the input relay.
 - b. Remove the two screws securing the input relay to the bracket.
 - c. Using a $\frac{5}{16}$ inch wrench, disconnect the SMA cable at RF INPUT.
 - d. Using a $\frac{5}{16}$ inch wrench, disconnect the SMA cables W101, W107, and W119 on the input relay. Lift up and remove the input relay.
 - e. If necessary, remove the four screws securing the bracket to the main chassis. Lift up and remove the bracket.
5. *Reinstallation:* Reverse step 3 through 4 to reinstall the RF1 modules.

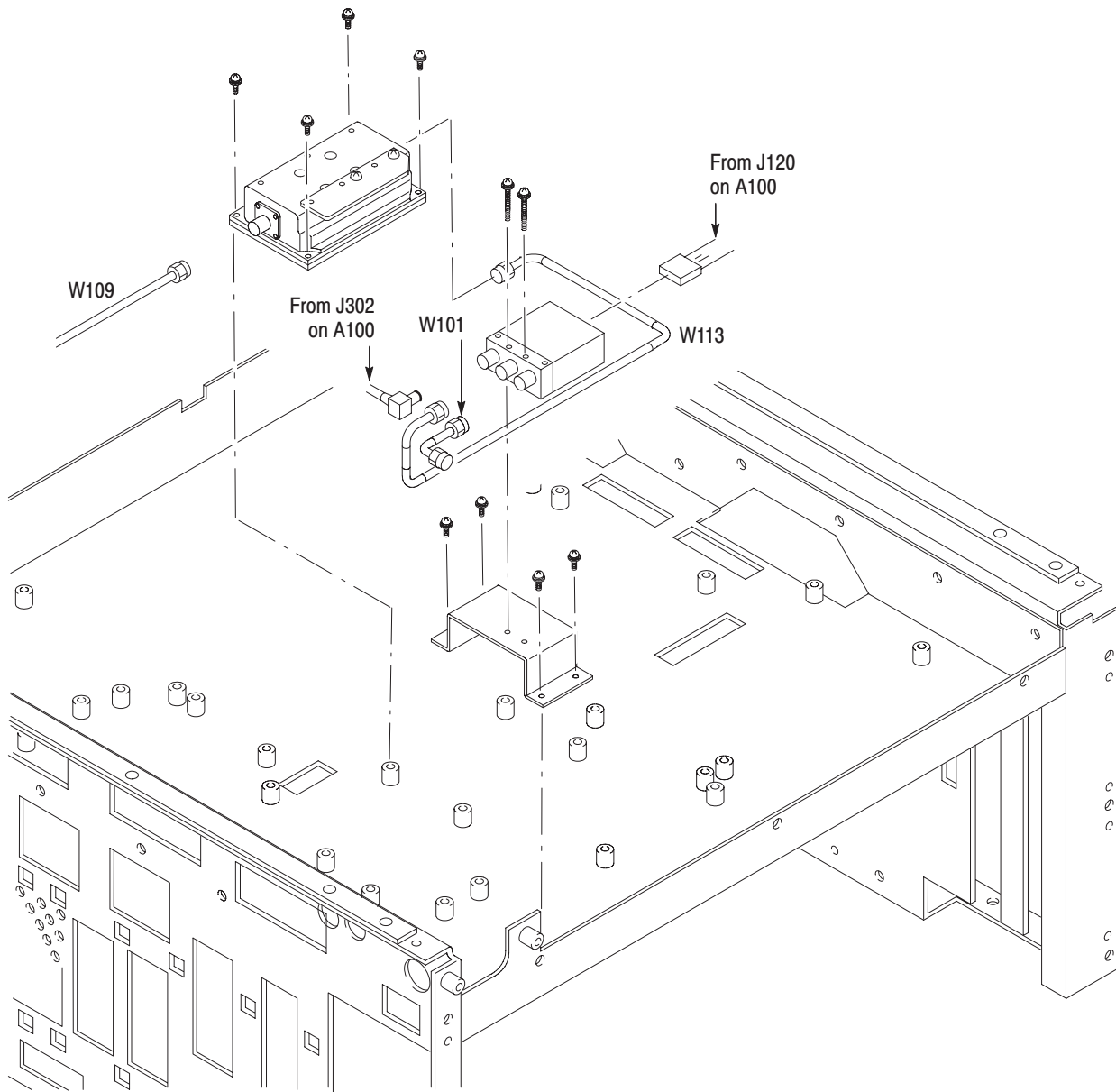

Figure 6-24: RF1 modules removal - 2 (RSA2203A)

**Input Relay,
Programmable BPF,
Step Attenuator, and
Band Relay
(for RSA2208A)**

1. *Assemble equipment and locate module to be removed:*
 - a. You will need a #1 Phillips screwdriver (Items 1 and 2) and a $\frac{5}{16}$ inch wrench (Item 11).
 - b. Locate the modules in the locator diagram *Bottom modules – RF1*, Figure 6–8, page 6–18.
2. *Orient the analyzer:* Set the analyzer so its top is down on the work surface and its front is facing you.
3. Remove the cables on the A100 Interconnection board (Refer to the *A100 Interconnection Board* procedure on page 6–47).

See Figure 6–25 for the following steps 4 through 8. Also see Figure 6–37 for cable interconnection.

4. *Remove the base plate with the modules:*
 - a. Using a $\frac{5}{16}$ inch wrench, disconnect the SMA cable W101 at the RF INPUT.
 - b. Using a $\frac{5}{16}$ inch wrench, disconnect the SMA cable W106 at the 3 dB attenuator on the programmable band-pass filter.
 - c. Remove the two screws securing the base plate through the A100 Interconnection board to the main chassis.
 - d. Remove the four screws securing the base plate to the main chassis.
 - e. Lift up the base plate with the modules.
5. *Remove the input relay:*
 - a. Using a $\frac{5}{16}$ inch wrench, disconnect the SMA cables W101, W120, and W119 on the input relay.
 - b. Disconnect the cable W114 on the input relay.
 - c. Remove the two screws securing the input relay to the base plate. Lift up the input relay.
6. *Remove the programmable band-pass filter:*
 - a. Using a $\frac{5}{16}$ inch wrench, disconnect the SMA cable W123 on the filter.
 - b. Remove the four screws securing the bracket to the base plate. Lift up the bracket with the filter.
 - c. Remove the four screws securing the filter to the bracket.
 - d. Remove the 3 dB attenuator at each side of the filter using a $\frac{5}{16}$ inch wrench.

7. Remove the step attenuator:

- a.** Remove the three screws securing the bracket to the base plate.
Lift up the bracket with the attenuator.
- b.** Using a $\frac{5}{16}$ inch wrench, disconnect the SMA cables W120 and W121 on the attenuator.
- c.** Remove the two screws securing the bracket to the attenuator.
Lift up the bracket away.

8. Remove the band relay:

- a.** Using a $\frac{5}{16}$ inch wrench, disconnect the SMA cables W121, W122, and W123 on the band relay.
- b.** Unplug the cable W114A on the band relay.
- c.** Remove the two screws securing the band relay to the base plate.
Lift up the band relay.
- d.** Unsolder the A150 YTF interface board at four points to remove it from the band relay.

9. Reinstallation: Reverse steps 3 through 8 to reinstall the RF1 modules.

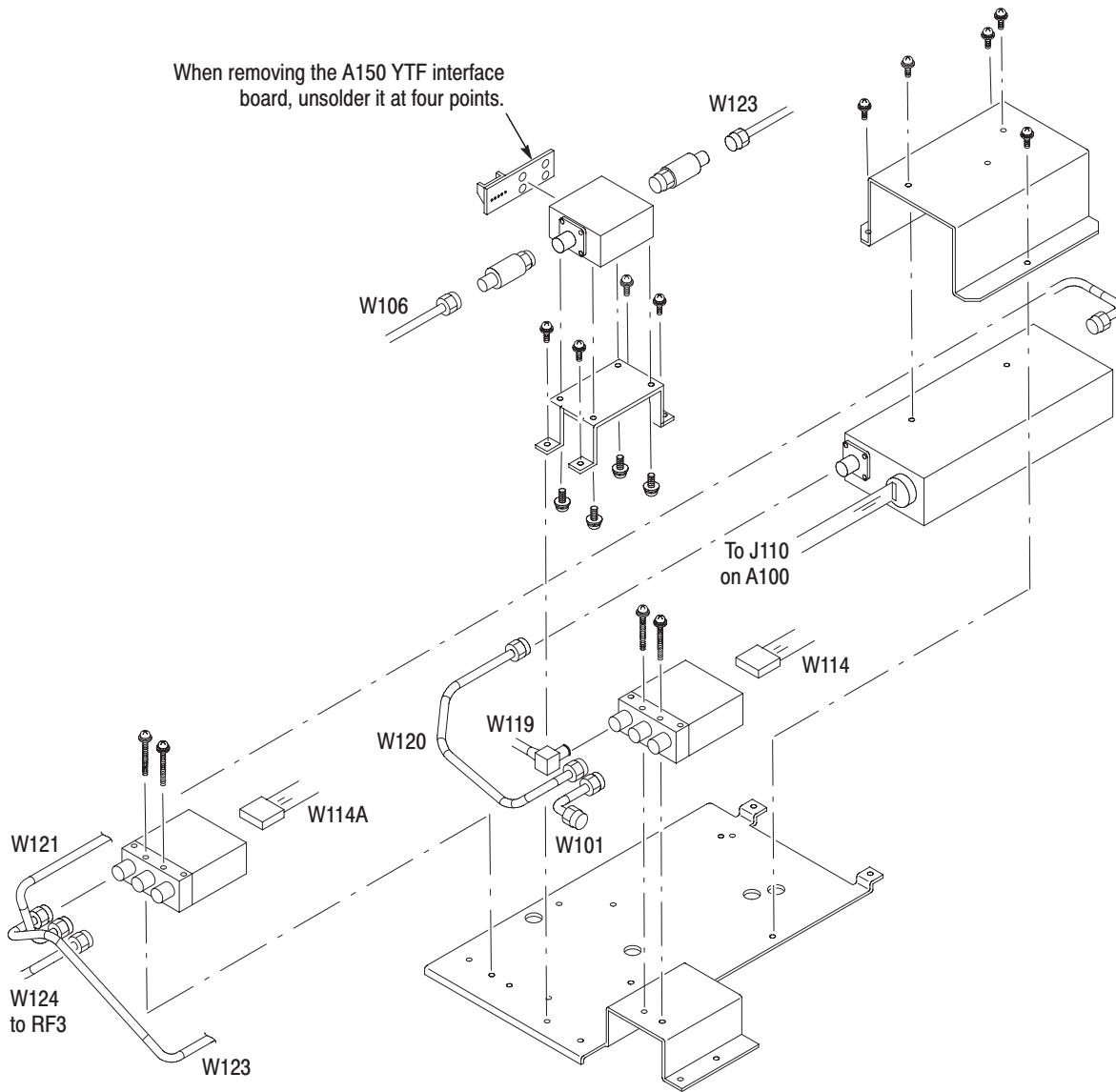

Figure 6-25: RF1 modules removal - 2 (RSA2208A)

Procedures for Front Panel Modules

Read the *Access Procedure* on page 6–21 before proceeding. The procedures are presented in the following order:

- *Front-panel assembly*
- *Rotary encoder*
- *Front Bezel, Menu Buttons, and Front Panel*
- *A60 Front key board*
- *A61 Power switch board*
- *Preamp power connector*
- *RF input connector*
- *LCD display*

Front-Panel Assembly

1. *Assemble equipment and locate module to be removed:*
 - a. You will need a #2 Phillips screwdriver (Items 1 and 3).
 - b. Locate the front panel assembly in the locator diagram *Front panel modules*, Figure 6–9, page 6–19.
 - c. Remove the front cushions at both sides (Refer to the *Front Cushion* procedure on page 6–23).
2. *Orient the analyzer:* Set the analyzer so its bottom is down on the work surface and its front is facing you.
3. *Remove the front panel assembly:* See Figure 6–26.
 - a. Unplug the preamplifier power cable at J810 on the A50 Mother board.
 - b. Unplug the cable at J60 on the A50 Mother board.
 - c. Remove the two screws securing the front-panel assembly to the main chassis at each side. Lift the front-panel assembly away.
4. *Reinstallation:* Reverse step 3 to reinstall the front-panel assembly.

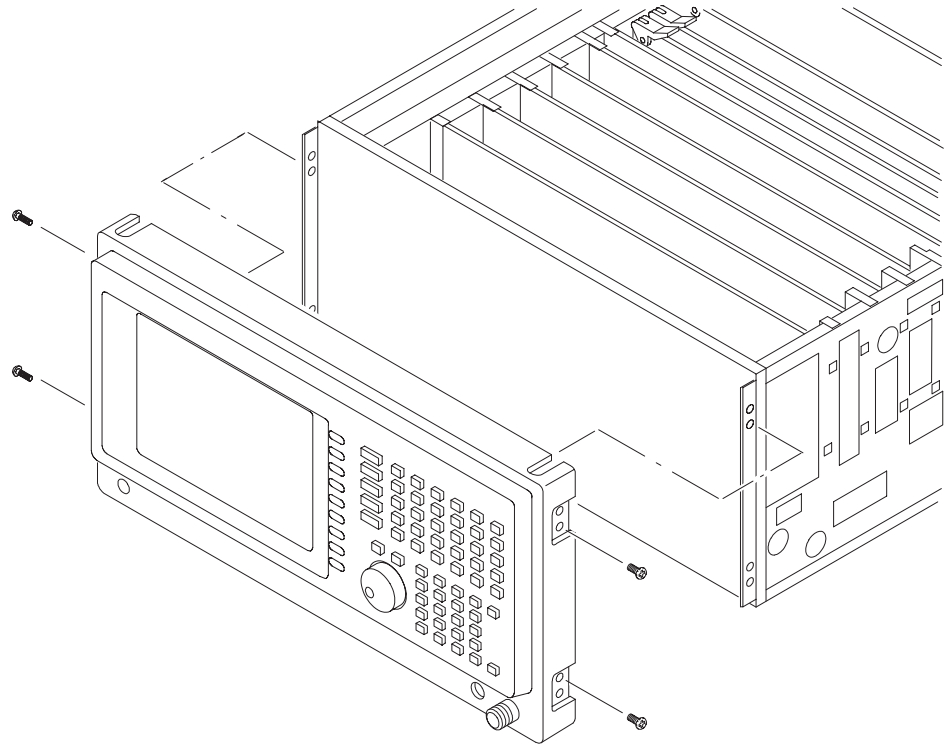

Figure 6-26: Front panel assembly removal

Rotary Encoder

1. *Assemble equipment and locate module to be removed:*
 - a. You will need a 12 mm nutdriver (Item 7), and a $\frac{1}{16}$ inch hex wrench (Item 10).
 - b. Locate the rotary encoder in Figure 6-9, page 6-19.
2. *Orient the front-panel assembly:* Set the front-panel assembly so its back is down on the work surface and its front is facing you.
3. *Remove the general purpose knob:* See Figure 6-27. Loosen the setscrew securing the knob using the $\frac{1}{16}$ inch hex wrench. Pull the knob away.
4. *Remove the rotary encoder:* See Figure 6-27.
 - a. Unplug the rotary encoder cable at J140 on the A60 Front key board.
 - b. Using the 12 mm nutdriver, remove the nut securing the rotary encoder to the front bezel.
5. *Reinstallation:* Reverse steps 3 and 4 to reinstall the rotary encoder and the general purpose knob.

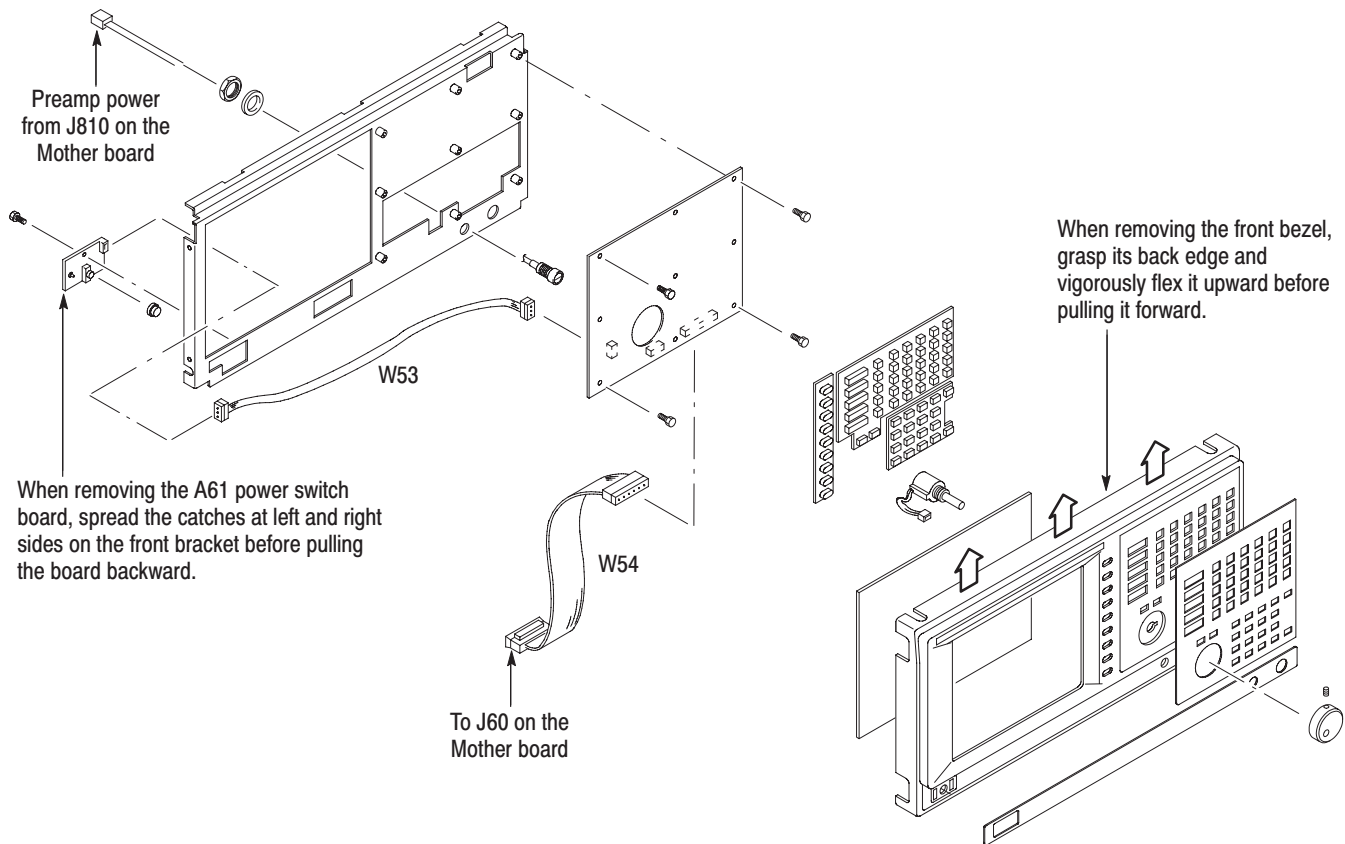

Figure 6-27: Front panel modules removal

Front Bezel, Menu Buttons and Front Panel

1. *Assemble equipment and locate modules to be removed:* No tools are needed. Locate the modules to be removed in the locator diagram *Front panel modules*, Figure 6-9, page 6-19.
2. *Orient the front-panel assembly:* Set the front-panel assembly so its back is down on the work surface and its front is facing you.
3. *Remove the front bezel and menu buttons:* See Figure 6-27. Grasp the front bezel by its top edge, pry it up, and lift it forward to snap it off of the front bracket. If servicing the menu buttons, lift them out of the front bezel.
4. *Remove the front panel:* Unstick the front panel from the front bezel to remove it.
5. *Reinstallation:* Reverse steps 3 and 4 to reinstall the front panel, menu buttons, and front bezel.

A60 Front Key Board

1. *Assemble equipment and locate module to be removed:*
 - a. You will need a #2 Phillips screwdriver (Items 1 and 3).
 - b. Locate the A60 Front key board in the locator diagram *Front panel modules*, Figure 6–9, page 6–19.
2. *Orient the front-panel assembly:* Set the front-panel assembly so its back is down on the work surface and its front is facing you.
3. *Remove the A60 Front key board:* See Figure 6–27.
 - a. Unplug the cable at J120 and J130 on the A60 board.
 - b. Remove the four screws securing the A60 board to the front bracket. Lift up and remove the A60 board.
4. *Reinstallation:* Reverse step 3 to reinstall the A60 board.

A61 Power Switch Board

1. *Assemble equipment and locate module to be removed:*
 - a. You will need a #2 Phillips screwdriver (Items 1 and 3).
 - b. Locate the A61 Power switch board in the locator diagram *Front panel modules*, Figure 6–9, page 6–19.
2. *Orient the front-panel assembly:* Set the front-panel assembly so its front is down on the work surface and its back is facing you.
3. *Remove the A61 Power switch board:* See Figure 6–27.
 - a. Unplug the cable at J100 on the A61 board.
 - b. Remove the one screw securing the A61 board to the front bracket.
 - c. Spreading the catches at left and right sides on the front bracket, lift the A61 board up away.
4. *Reinstallation:* Reverse step 3 to reinstall the A61 board.

Preamp Power Connector

1. *Assemble equipment and locate module to be removed:*
 - a. You will need a 14 mm nutdriver (Items 8).
 - b. Locate the preamp power connector in the locator diagram *Front panel modules*, Figure 6–9, page 6–19.
2. *Orient the front-panel assembly:* Set the front-panel assembly so its front is down on the work surface and its back is facing you.
3. *Remove the preamplifier power connector:* See Figure 6–27. Using the 14 mm nutdriver, remove the nut securing the connector to the front bracket.

4. *Reinstallation:* Reverse step 3 to reinstall the preamp power connector.

RF Input Connector

1. *Assemble equipment and locate module to be removed:*
 - a. You will need a #2 Phillips screwdriver (Items 1 and 3), a $\frac{9}{16}$ inch nutdriver (Item 9), and a $\frac{5}{16}$ inch wrench (Item 11).
 - b. Locate the RF input connector in Figure 6–9, page 6–19.
 - c. Remove the front-panel assembly (Refer to the *Front-Panel Assembly* procedure on page 6–54).
2. *Orient the analyzer:* Set the analyzer so its bottom is down on the work surface and its front is facing you.
3. *Remove the RF input connector:* See Figure 6–28.
 - a. Using a $\frac{5}{16}$ inch wrench, disconnect the SMA cable W101 at RF INPUT. See Figure 6–36 (RSA2203A, page 6–74) or Figure 6–37 (RSA2208A, page 6–75) for cable interconnection.
 - b. Using a #2 Phillips screwdriver, remove the three screws securing the connector plate to the front sub-panel. Remove the connector with the plate from the front sub-panel.
 - c. Using the $\frac{9}{16}$ inch nutdriver, remove the nut securing the connector to the plate. Remove the connector from the plate.
4. *Reinstallation:* Reverse step 3 to reinstall the RF input connector.

LCD Display

1. *Assemble equipment and locate module to be removed:*
 - a. You will need a #2 Phillips screwdriver (Items 1 and 3).
 - b. Locate the LCD display in the locator diagram *Front panel modules*, Figure 6–9, page 6–19.
 - c. Remove the front-panel assembly (Refer to the *Front-Panel Assembly* procedure on page 6–54).
2. *Orient the analyzer:* Set the analyzer so its bottom is down on the work surface and its front is facing you.
3. *Remove the inverter:* See Figure 6–28.
 - a. Unplug the cables at CN1 and CN2 on the inverter.
 - b. Remove the two screws securing the inverter to the front sub-panel.

4. *Remove the LCD display:* See Figure 6–28.
 - a. Unplug the cables at CN1 and CN2 on the inverter.
 - b. Remove the two screws securing the inverter to the front sub-panel. Lift up and remove the LCD display.
5. *Reinstallation:* Reverse steps 3 and 4 to reinstall the LCD display and interconnect cables.

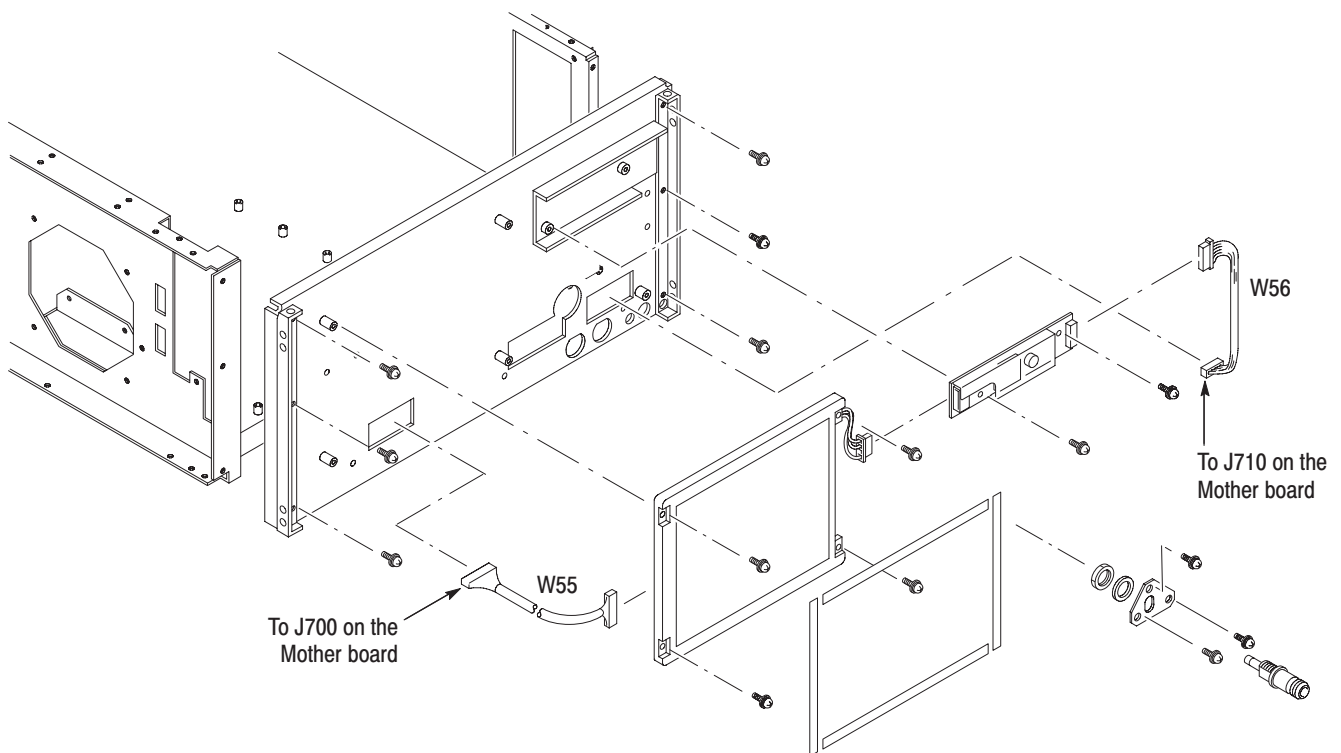

Figure 6–28: LCD display removal

Procedures for Chassis Modules

Read the *Access Procedure* on page 6–21 before proceeding. The procedures are presented in the following order:

- *Fan*
- *Side panel assembly*
- *Board guide bracket*
- *Rear panel modules*

- Fan**
1. *Assemble equipment and locate module to be removed:*
 - a. You will need a #2 Phillips screwdriver (Items 1 and 3).
 - b. Locate the fan in the *Chassis modules* locator diagram, Figure 6–10, page 6–20.
 - c. Remove the cabinet (Refer to the *Cabinet* procedure on page 6–22).
 2. *Orient the analyzer:* Set the analyzer so its bottom is down on the work surface and its front is facing you.
 3. *Remove the fan:* See Figure 6–29.
 - a. Unplug the fan’s power cable at J300 and J302 on the A70 DC power board. Refer to the *A70 DC Power Board* procedure on page 6–38.
 - b. Remove the four screws securing the fan to the main chassis. Pull the fan away.
 4. *Reinstallation:* Reverse step 3 to reinstall the fan.

- Side Panel Assembly**
1. *Assemble equipment and locate module to be removed:*
 - a. You will need a #2 Phillips screwdriver (Items 1 and 3).
 - b. Locate the side panel assembly in the *Chassis modules* locator diagram, Figure 6–10, page 6–20.
 - c. Remove the cabinet (Refer to the *Cabinet* procedure on page 6–22).
 2. *Orient the analyzer:* Set the analyzer so its bottom is down on the work surface and its left side is facing you.
 3. Perform the *CPU Board and Disk Modules* procedure on page 6–31 to remove the CPU board and the disk bracket.

4. *Remove the side panel assembly:* See Figure 6–29.
 - a. Remove the three screws securing the shield bracket through side panel to the main chassis.
 - b. Remove the two screws securing the side panel to the main chassis. Pull the side panel away.
 - c. Pull out the stopper bracket to complete the removal.
5. *Reinstallation:* Reverse steps 3 and 4 to reinstall the side panel assembly.

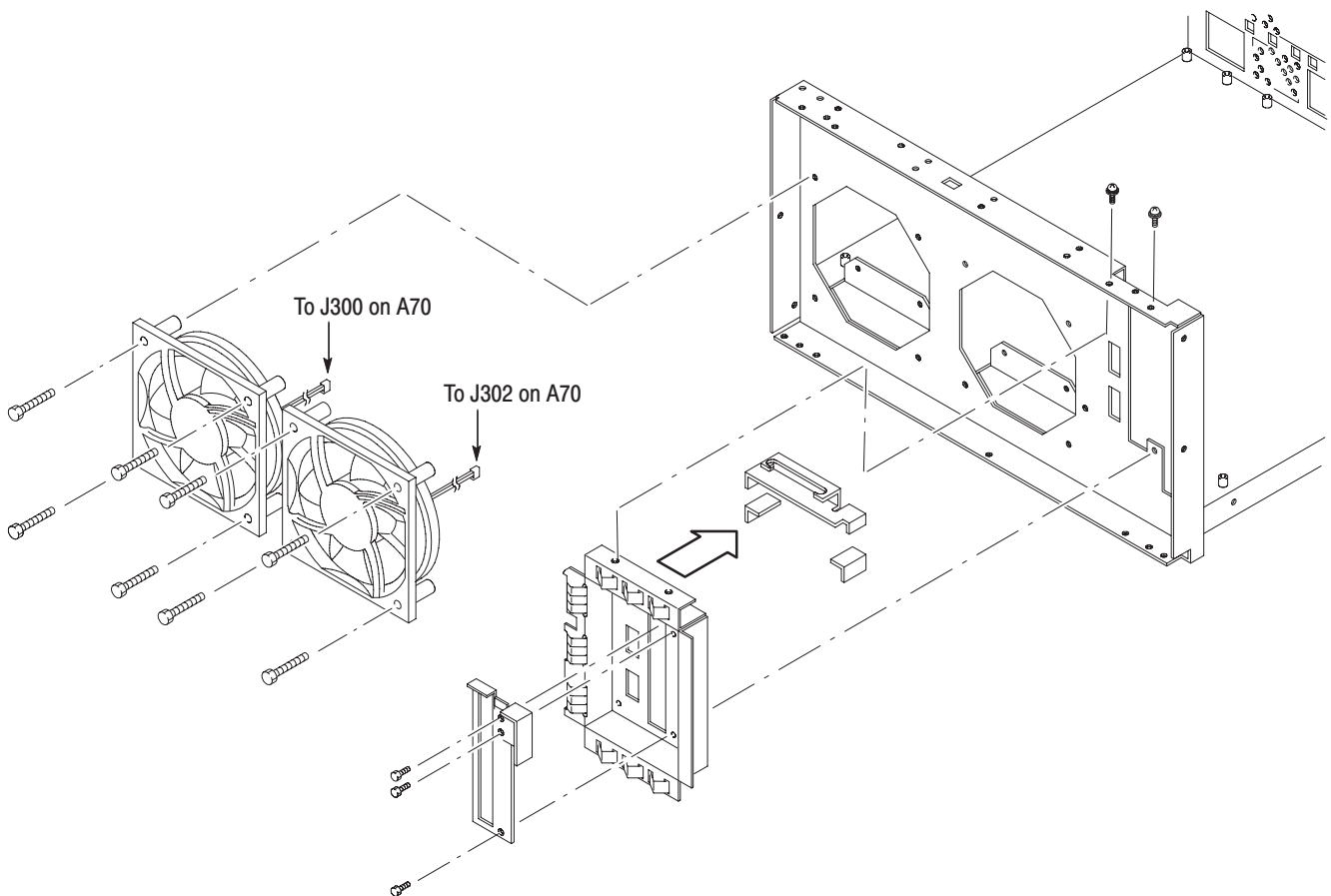

Figure 6–29: Fan and side panel removal

Board Guide Bracket

1. *Assemble equipment and locate module to be removed:*
 - a. You will need a #2 Phillips screwdriver (Items 1 and 3).
 - b. Locate the board guide bracket in the *Chassis modules* diagram, Figure 6–10, page 6–20.
 - c. Remove the RF modules (Refer to the *RF Modules* procedure on page 6–27).
 - d. Remove all the daughter boards (Refer to the procedure *Mother Board and its Daughter Modules* on page 6–36).
2. *Orient the analyzer:* Set the analyzer so its bottom is down on the work surface and its left side is facing you.

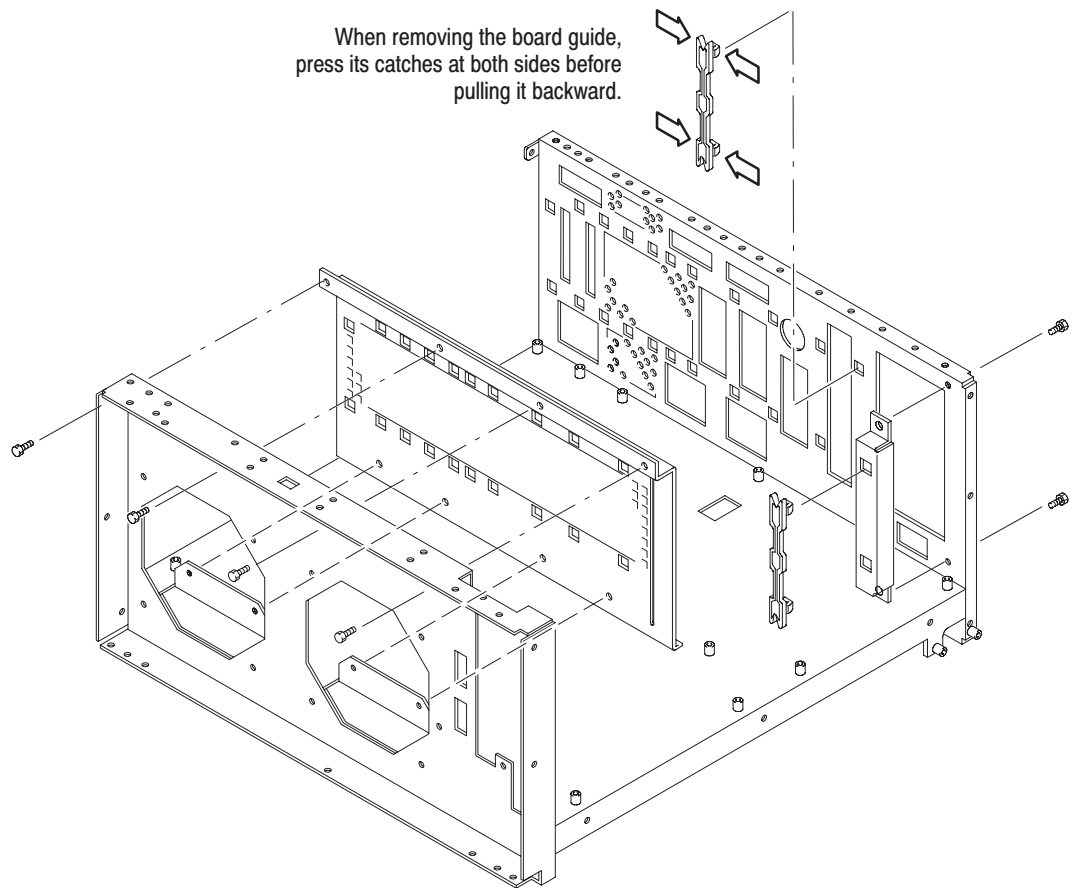

Figure 6–30: Board guide bracket removal

3. *Remove the board guide bracket:* Remove the four screws securing the board guide bracket to the main chassis. Lift the bracket up and away.
4. *Remove the PC board guide bracket:* Remove the two screws securing the PC board guide bracket to the main chassis. Lift the bracket up and away.
5. *Reinstallation:* Reverse steps 3 and 4 to reinstall the board guide brackets.

Rear Panel Modules

1. *Assemble equipment and locate module to be removed:*
 - a. You will need a screwdriver with #1 and #2 Phillips tips (Items 1, 2 and 3) and a flat-bladed screwdriver (Item 4).
 - b. Locate the rear panel modules in the *Chassis modules* diagram, Figure 6–10, page 6–20.
2. *Orient the analyzer:* Set the analyzer so its bottom is down on the work surface and its rear is facing you.
3. *Remove the SMB-BNC connector:* See Figure 6–31.
 - a. Unplug the coaxial cable from the connector.
 - b. Using a screwdriver with a #1 Phillips tip, remove the four screws securing the connector to the rear chassis. Pull the connector away.
4. *Remove the GPIB connector:* See Figure 6–31.
 - a. Unplug the cable at J410 on the A70 DC power board. Refer to the *A70 DC Power Board* procedure on page 6–38.
 - b. Using a flat-bladed screwdriver, remove the two screws securing the connector to the rear panel. Pull the connector away.
5. *Standard type only. Remove the blank plate:* Remove the two screws securing the blank plate to the rear panel. Lift the blank plate away.
6. *Remove the rear panel:* Remove the two screws securing the rear panel to the main chassis. Lift up the rear panel away.
7. *Reinstallation:* Reverse steps 3 through 6 to reinstall the rear panel modules.

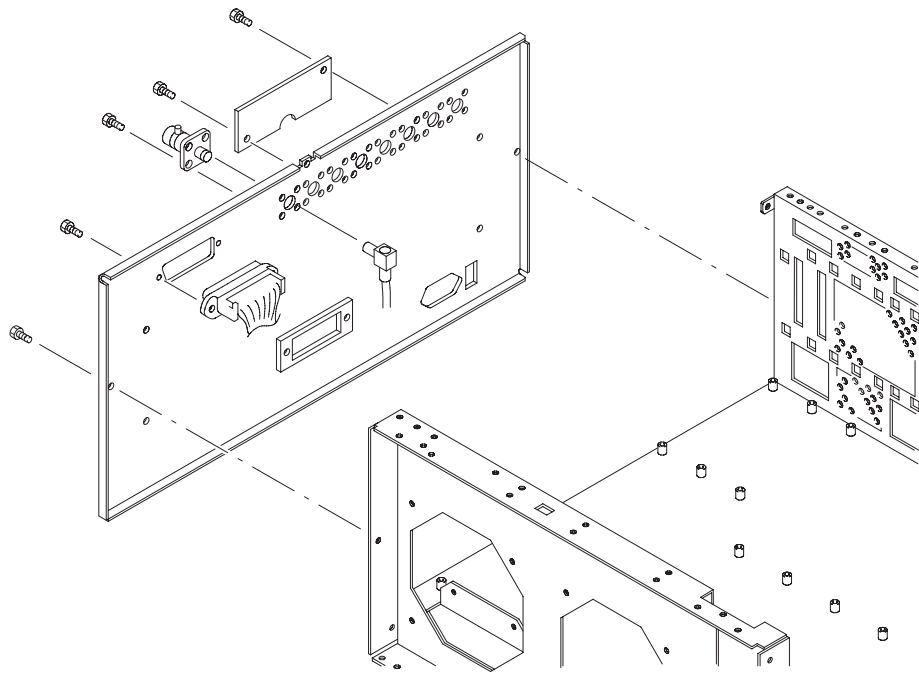

Figure 6-31: Rear panel modules

Troubleshooting

This subsection contains information and procedures designed to help you isolate faulty modules in the analyzer. If a module needs to be replaced, follow the *Removal and Installation Procedures* located in this section.

Troubleshooting Procedure

This subsection consists of the following flowcharts:

- Figure 6–32: Troubleshooting Procedure 1 — Power supply system
- Figure 6–33: Troubleshooting Procedure 2 — CPU and Display system
- Figure 6–34: Troubleshooting Procedure 3 — Signal path

If a fault is detected, first check that the power unit is operating properly according to “Troubleshooting Procedure 1 — Power supply modules”. Then, locate the faulty board according to the troubleshooting tree for each fault or the symptom/cause table.

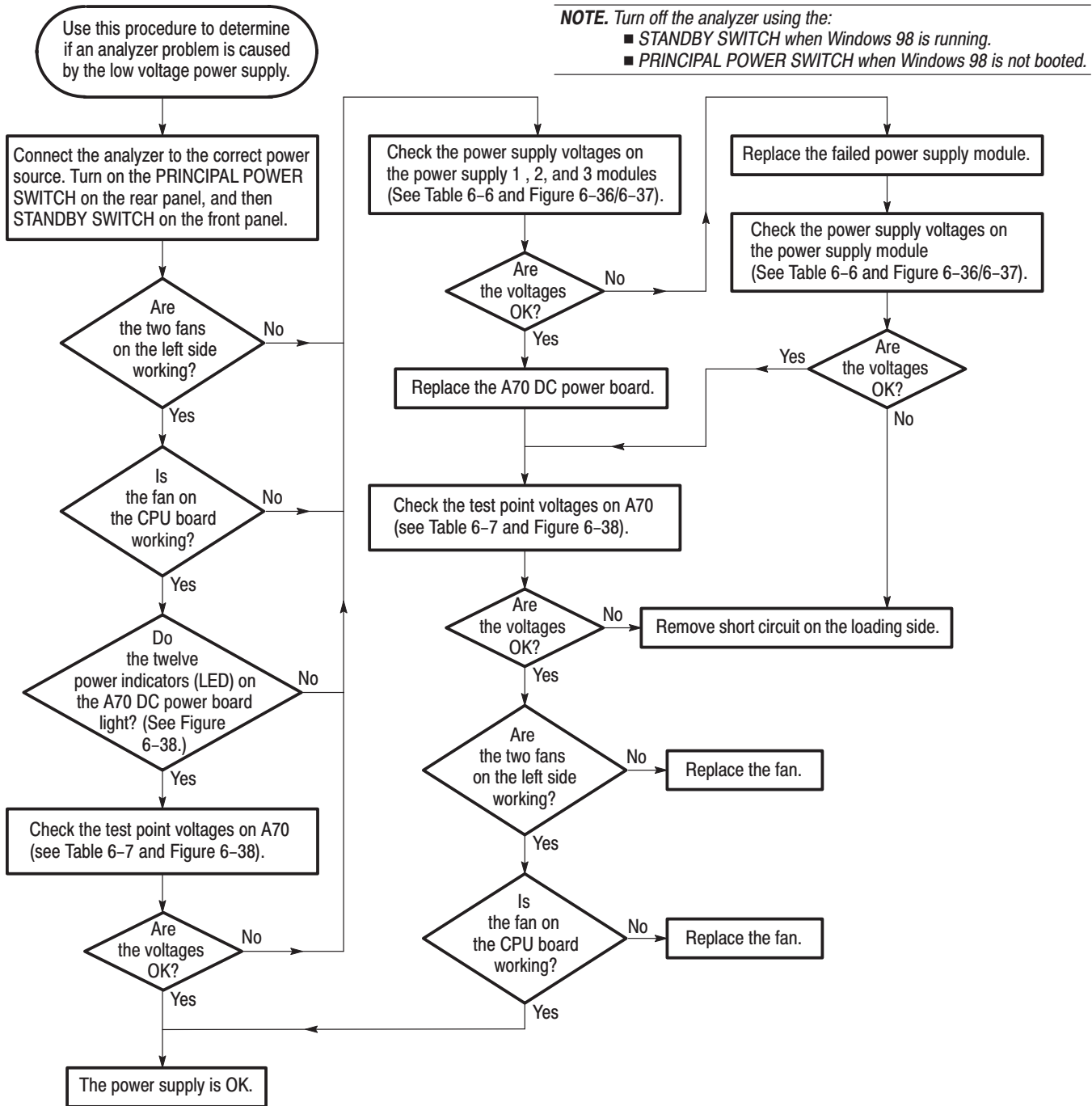

Figure 6-32: Troubleshooting procedure 1 — Power supply system

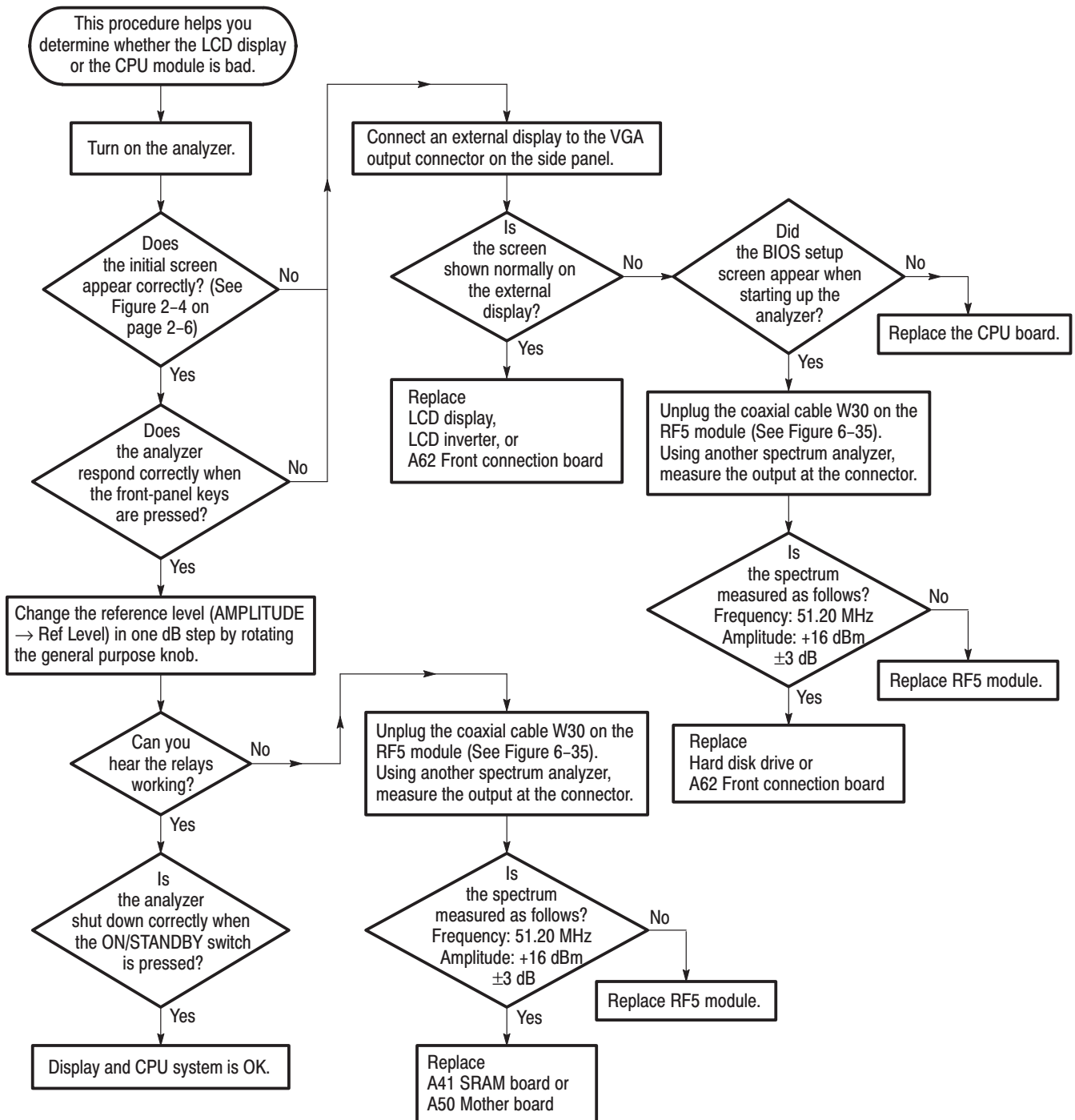

Figure 6-33: Troubleshooting procedure 2 — Display and CPU system

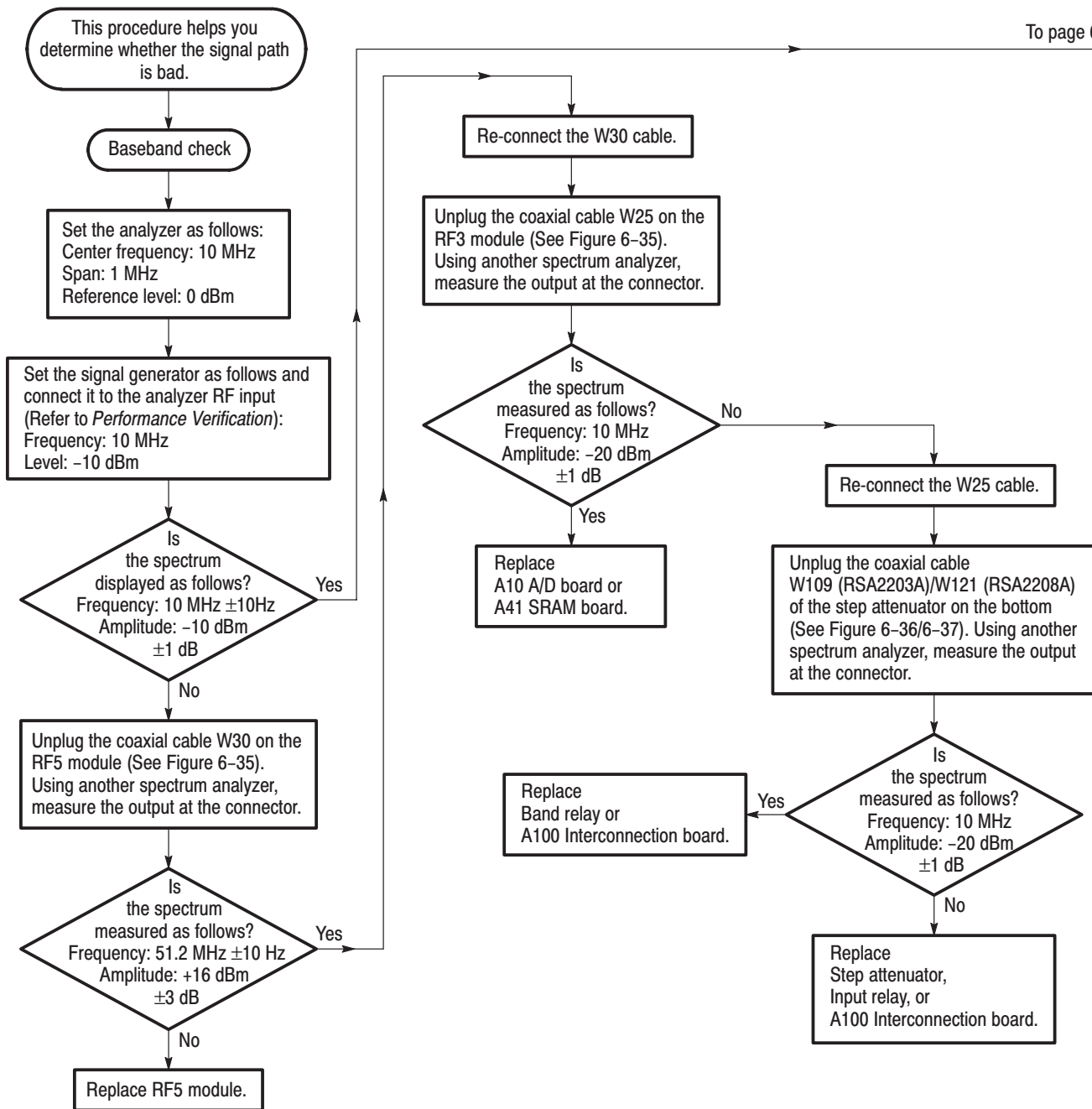

Figure 6-34: Troubleshooting procedure 3 — Signal path

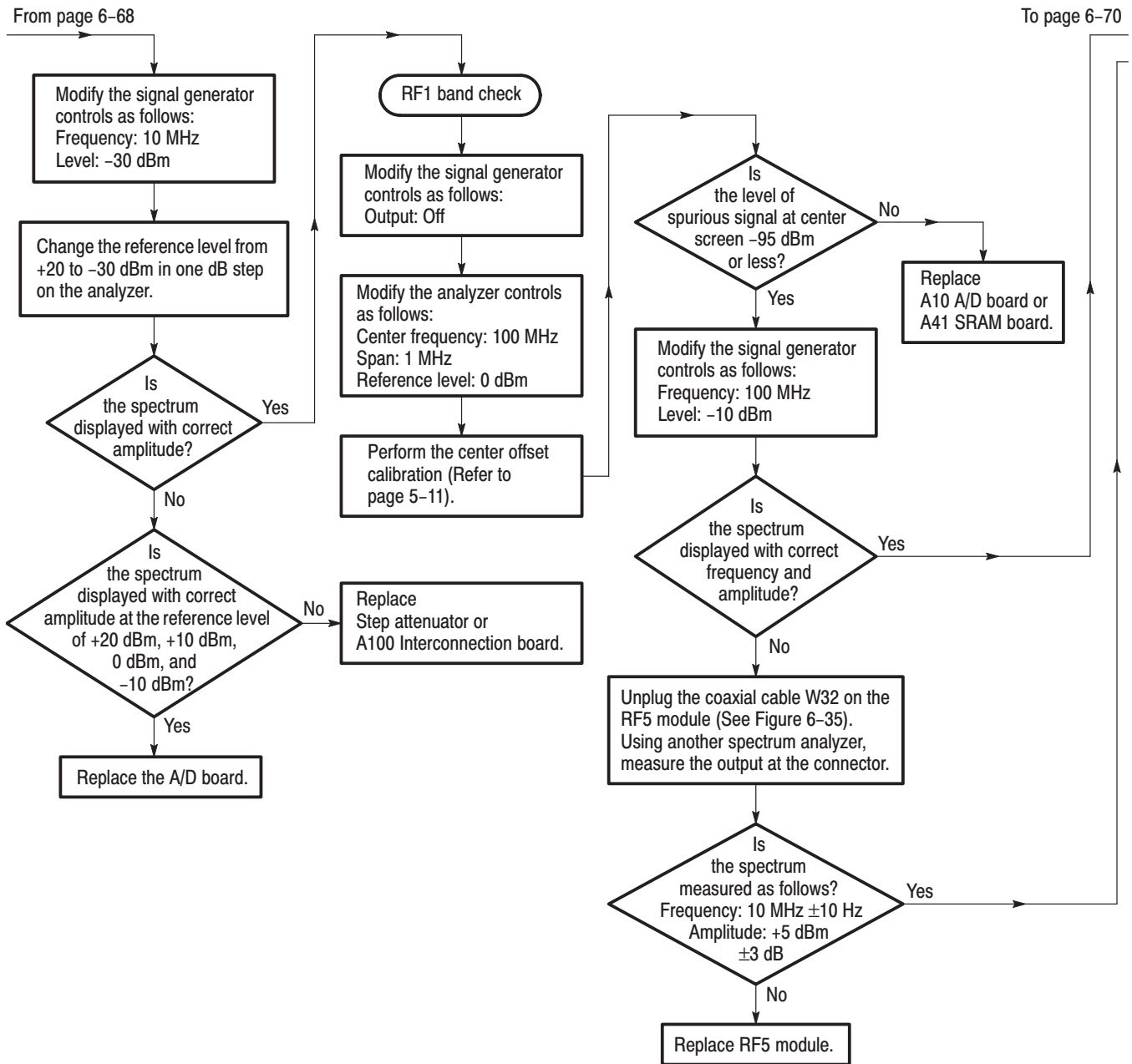

Figure 6-34: Troubleshooting procedure 3 — Signal path (Cont.)

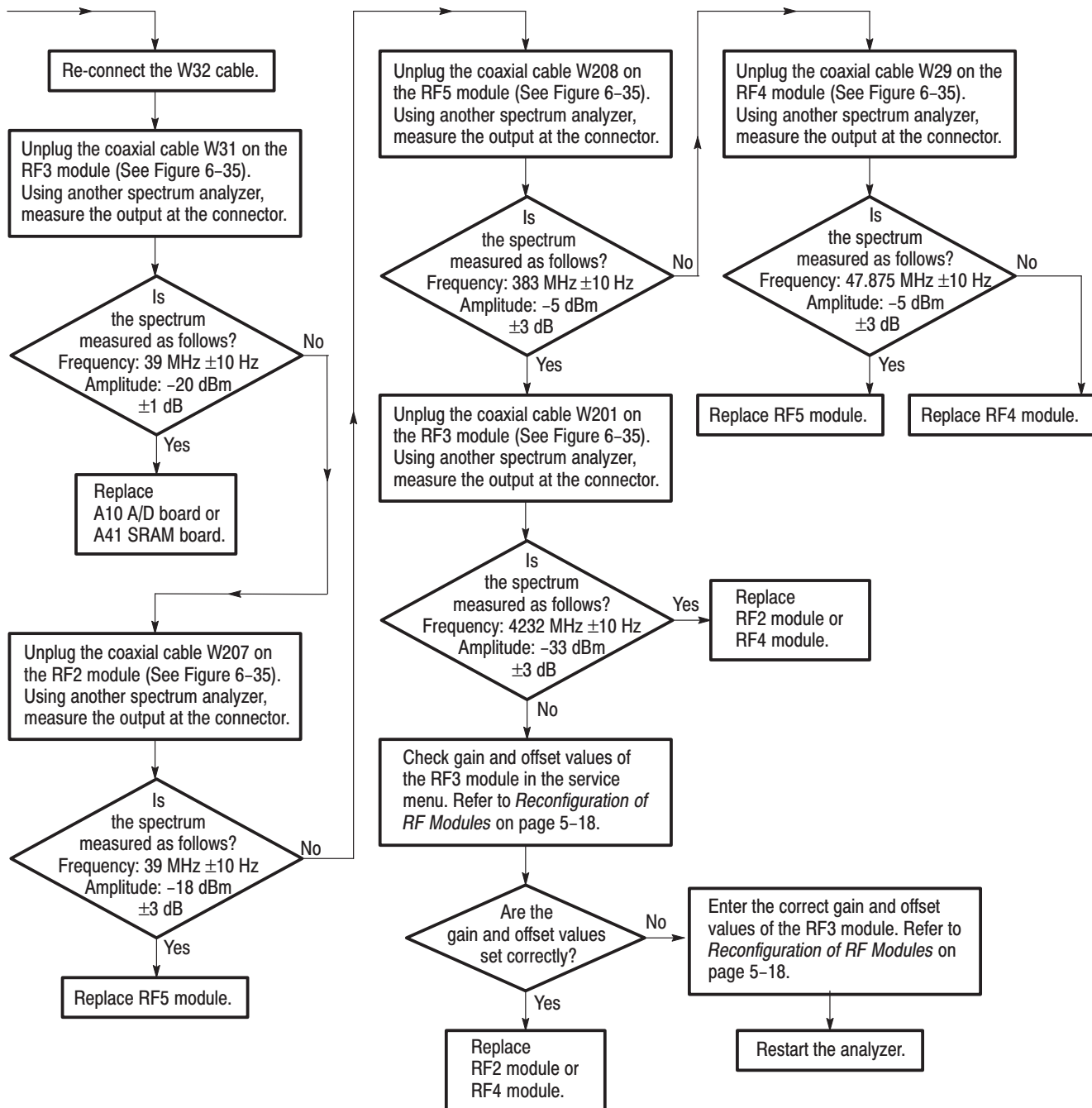

Figure 6-34: Troubleshooting procedure 3 — Signal path (Cont.)

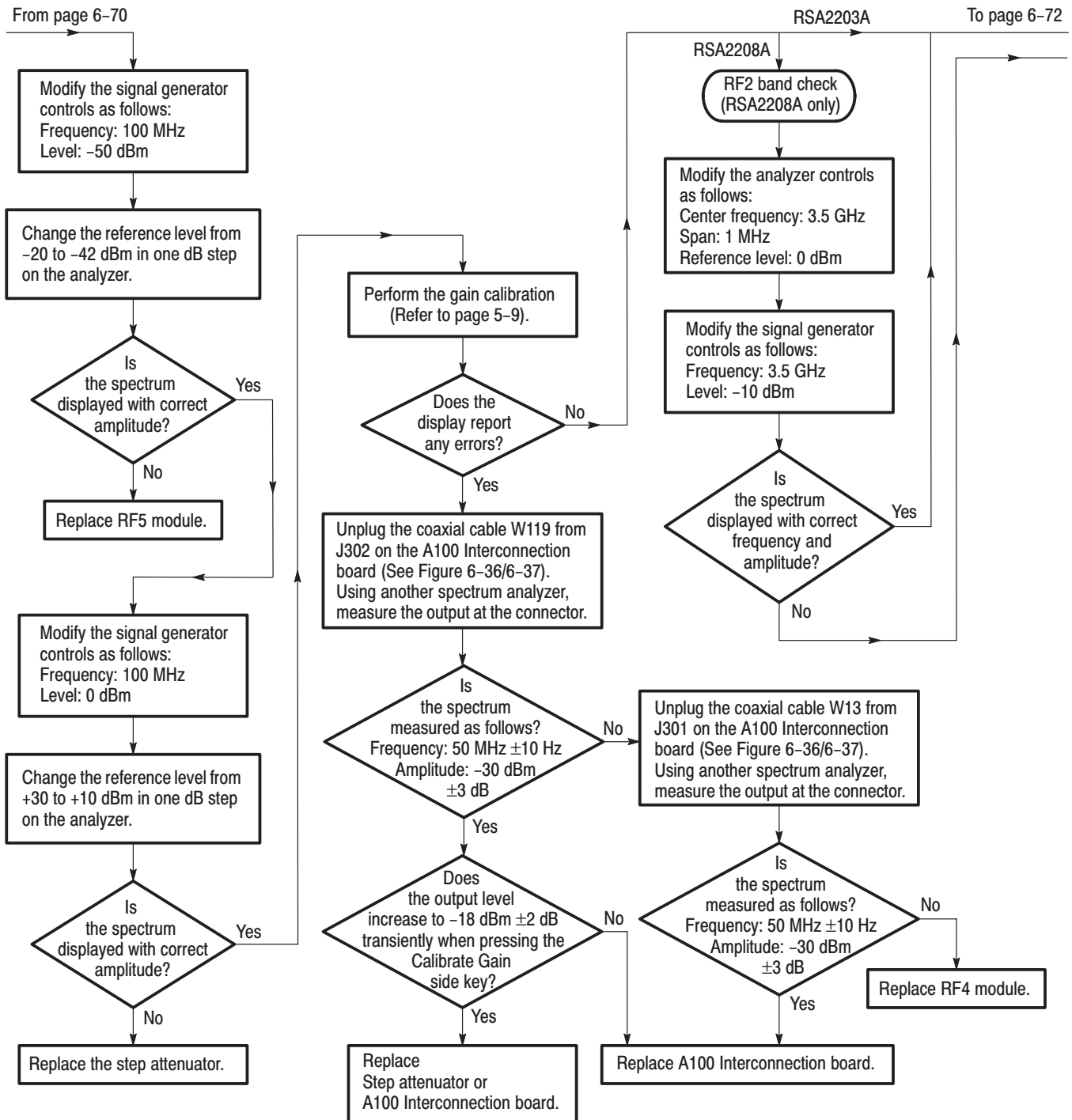

Figure 6-34: Troubleshooting procedure 3 — Signal path (Cont.)

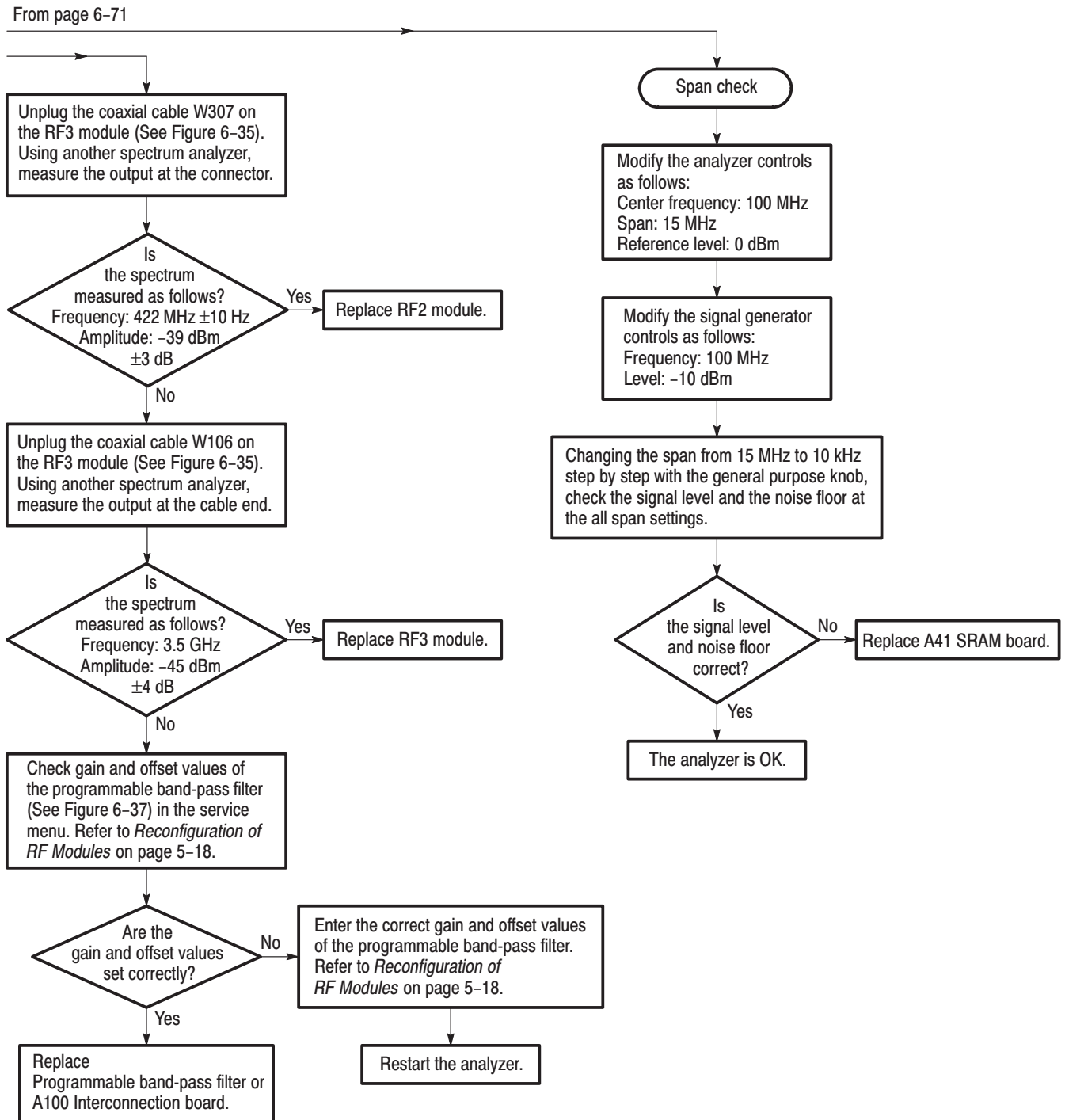

Figure 6-34: Troubleshooting procedure 3 — Signal path (Cont.)

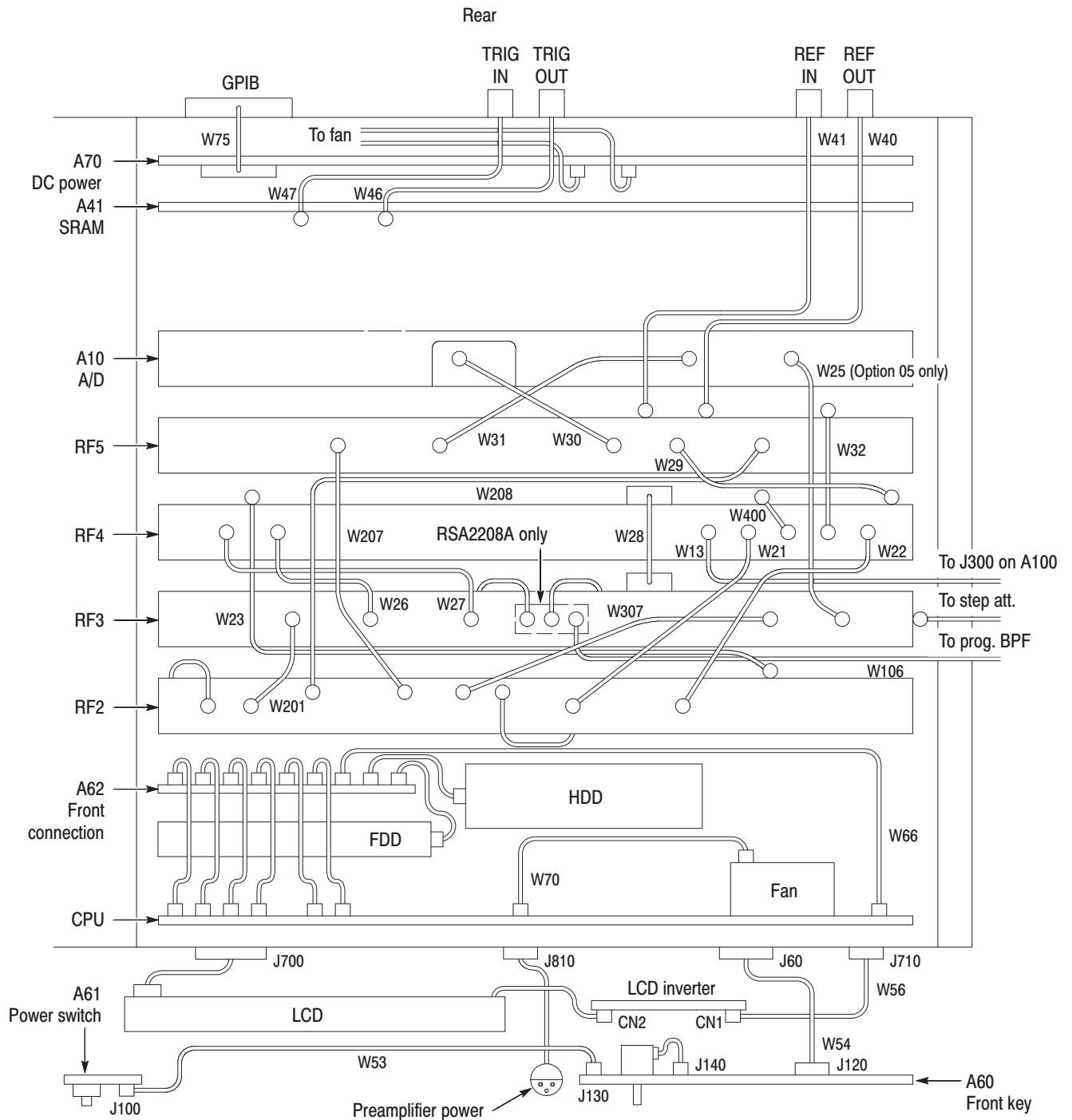

Figure 6-35: Top view for cable interconnection

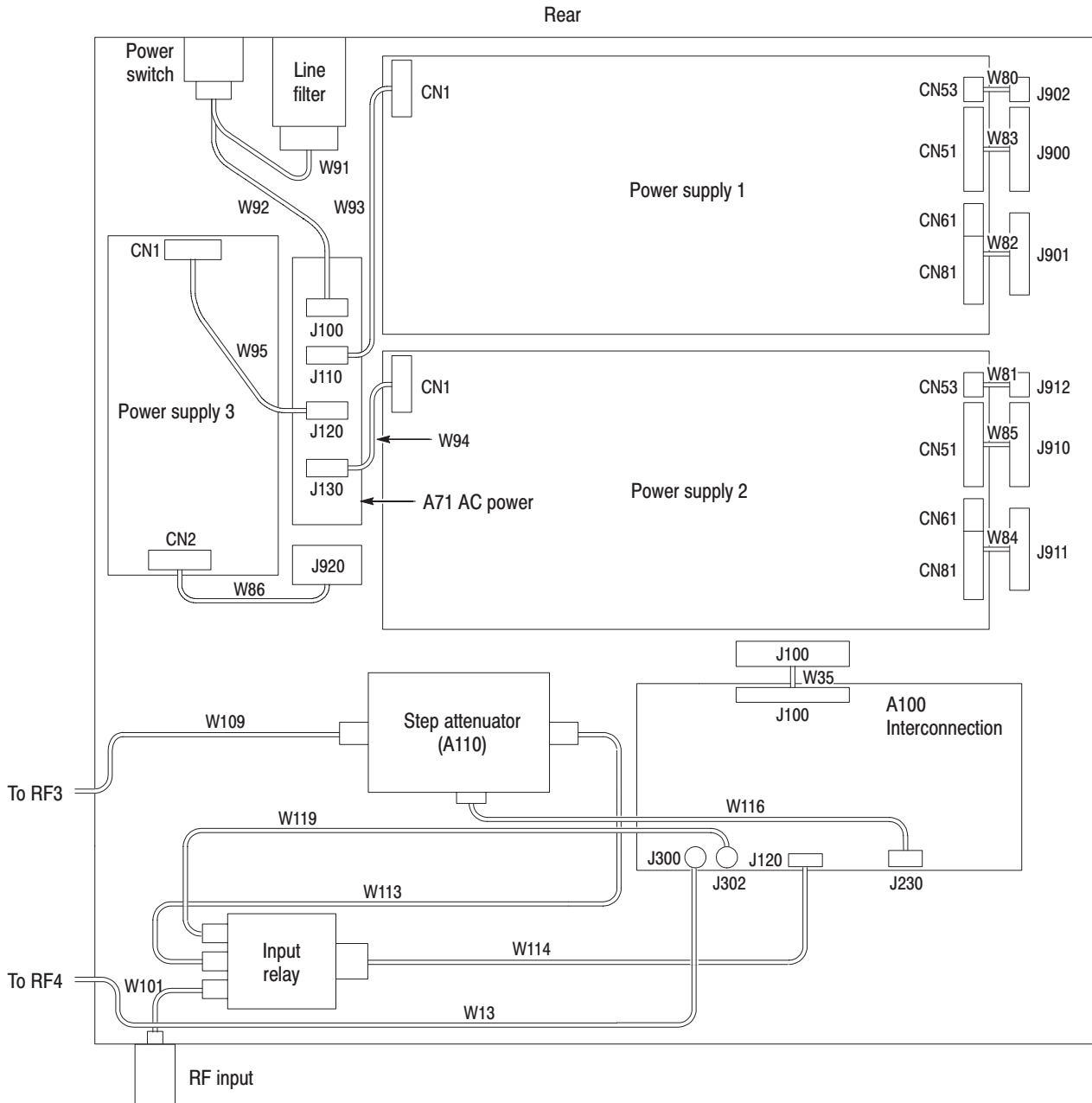

Figure 6-36: Bottom view for cable interconnection (RSA2203A)

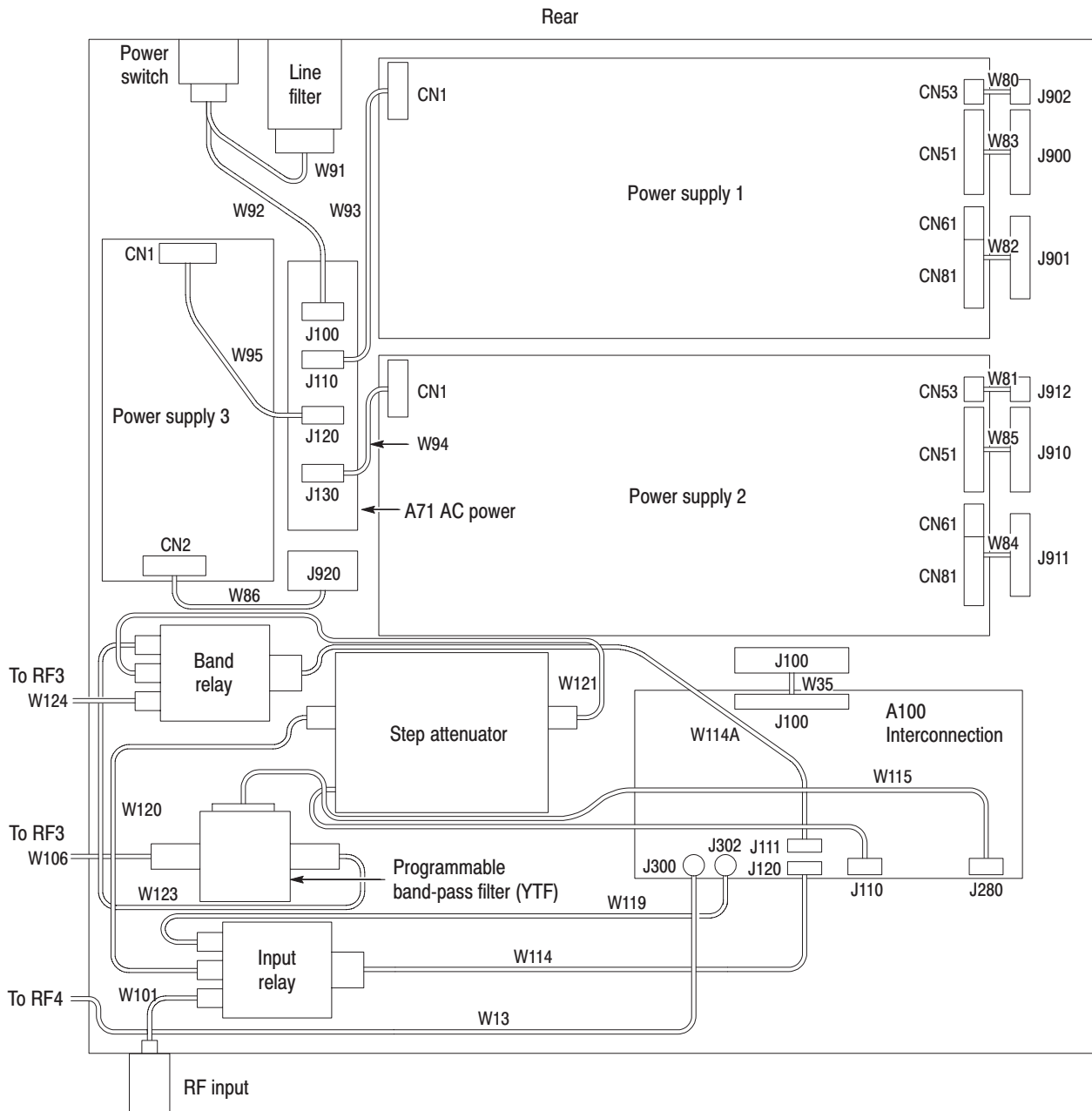

Figure 6-37: Bottom view for cable interconnection (RSA2208A)

Table 6-6: Normal supply voltages

Board	Connector	Pin no.	Normal	Low limit	High limit
Power supply 1	CN51	1	+5 V	+4.75 V	+5.25 V
		2	+5 V	+4.75 V	+5.25 V
		3	+5 V	+4.75 V	+5.25 V
	CN61	1	+15 V	+14.25 V	+15.75 V
		3	-15 V	-15.75 V	-14.25 V
	CN81	1	+24 V	+22.8 V	+25.2 V
		2	+24 V	+22.8 V	+25.2 V
	Power supply 2	CN51	1	+5 V	+4.75 V
2			+5 V	+4.75 V	+5.25 V
3			+5 V	+4.75 V	+5.25 V
CN61		1	+12 V	+11.4 V	+12.6 V
		3	-12 V	-12.6 V	-11.4 V
CN81		1	+3.3 V	+3.14 V	+3.46 V
		2	+3.3 V	+3.14 V	+3.46 V
Power supply 3		CN2	1	+5 V	+4.75 V
	2		+5 V	+4.75 V	+5.25 V
	5		+15 V	+14.25 V	+15.75 V

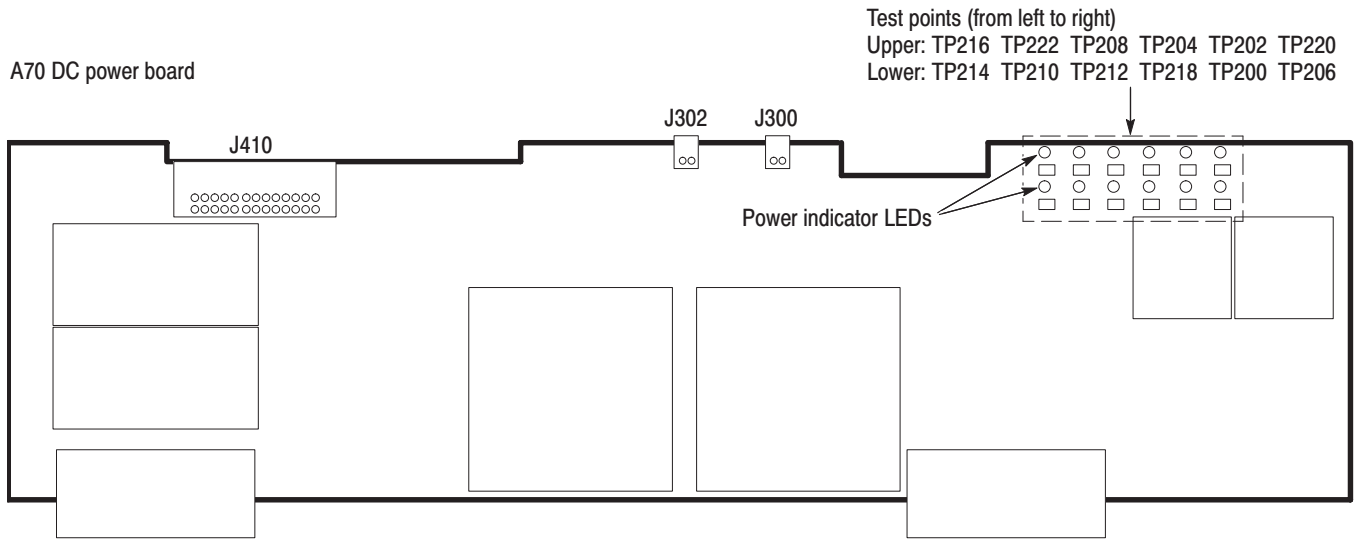

Figure 6-38: A70 DC power supply board

Table 6-7: Test point voltages on A70

Test point	Normal voltage	Low limit	High limit
TP216	+3.3 V	+3.14 V	+3.46 V
TP222	-6.6 V	-6.93 V	-6.27 V
TP208	+6.6 V	+6.27 V	+6.93 V
TP204	+9 V	+8.55 V	+9.45 V
TP202	+15 V	+14.25 V	+15.75 V
TP220	-6.6 V	-6.93 V	-6.27 V
TP214	+5 V	+4.75 V	+5.25 V
TP210	+6.6 V	+6.27 V	+6.93 V
TP212	+5 V	+4.75 V	+5.25 V
TP218	-15 V	-15.75 V	-14.25 V
TP200	+20 V	+19 V	+21 V
TP206	+6.6 V	+6.27 V	+6.93 V

Symptoms and Faulty Modules

Fault symptoms can help you identify faulty boards or modules. Fault symptoms and suspected boards or modules are listed in Table 6–8 below:

Table 6–8: Symptoms and faulty modules

Symptom (other functions are assumed to be normal)	Possible faulty module
No trigger signal is output from TRIG output connector.	A41 SRAM board
Cannot triggered with an external trigger signal.	A41 SRAM board
No reference signal is output from 10MHz REF OUT connector on the rear panel.	RF5 module
Displayed signal frequency shifts when selecting EXT as the reference source.	RF5 module
EXT IQ signal is not displayed, or signal level is incorrect.	A10 A/D board
Signal is not displayed or signal frequency shifts when you set up a specific (or in a specific range of) center frequency.	RF3 module or RF4 module
Noise floor excessively increases or spurious signal appears at specific span setting.	A41 SRAM board
Noise floor intermittently jumps high regardless of span or center frequency settings.	A10 AD or A41 SRAM board
Correct signal frequency and/or level are not displayed when span is set to a value greater than 20MHz.	RF3 module or RF4 module
Acquisition freezes when you set a specific span.	A41 SRAM board
Error message is displayed when you execute self gain-calibration.	A100 Interconnection board or RF4 module
GPIB does not work.	A62 Front connection board or A70 DC power board
Cannot turn off power using the ON/STANDBY switch.	CPU board or Windows hangs up.
Cannot turn off power using the ON/STANDBY switch while the power LED is not illuminated.	Power supply 3
Cannot turn off power using the ON/STANDBY switch while the power LED is illuminated.	CPU board
A front-panel key does not respond.	A60 Front key board, CPU board, or Windows hangs up.
Baseband mode does not work.	A10 A/D board
RF1 band does not work.	RF2 or RF3 module
RF2 or 3 band does not work.	RF3 module, Programmable BPF, or A100 Interconnection board

Notes for Changing Modules or Parts

When you change the following parts or modules, readjustment and/or recalibration are necessary. For details, refer to *Adjustment Procedures*.

RF3 Module

- You need to change the gain and offset values of YTO Tune DAC in the DEBUG menu. You can find the gain and offset values in a label located on the RF3 module.
- You must calibrate IF flatness, RF gain, and RF flatness for RF1, 2, and 3 bands.

RF2 and RF5 Modules

- You must calibrate IF flatness, RF gain, and RF flatness for RF1, 2, and 3 bands.

A10 A/D Board

- You must calibrate baseband gain and baseband flatness.
- You must calibrate IF flatness and RF gain for RF1, 2, and 3 bands.
- You must calibrate IQ gain.

Step Attenuator

- You must calibrate baseband gain.
- You must calibrate RF gain and RF flatness for RF1, 2, and 3 bands.

Programmable Band-pass Filter (YTF)

- You need to change the gain and offset values of YTF Tune DAC in the DEBUG menu. You can find the gain and offset values in a label located on the YTF module.
- You must calibrate RF gain, IF flatness, and RF flatness for RF2 and 3 bands.

A100 Interconnection Board

- You must calibrate RF gain for RF1 band.

Hard Disk Drive

- Full calibration is necessary because the cal factors are lost.
- Attach a new Windows license label.

Options

Options and Accessories

This appendix describes the options and standard and optional accessories that are available for the analyzer.

Options

The following options can be ordered for the analyzer:

- Option 1R: Rack Mount Kit (includes: hardware and instructions for converting to 19-inch rackmount configuration)
- Option 2A: External preamplifier (20 dB gain to 3 GHz)
- Option 05: DC-20 MHz baseband frequency extension
- Option 10: OCXO high stability reference oscillator, 1×10^{-9}
- Option 12: USB keyboard and mouse
- Option C3: Calibration service, 3 years
- Option C5: Calibration service, 5 years
- Option D1: Calibration data report
- Option D3: Calibration data report, 3 years (requires Option C3)
- Option D5: Calibration data report, 5 years (requires Option C5)
- Option L5: Provides Japanese language user manual and programmer manual instead of English manuals.
- Option R3: Repair service, 3 years
- Option R5: Repair service, 5 years
- Power cord options listed in Table 7-1.

Table 7-1: Power cord identification

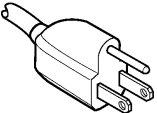
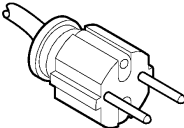
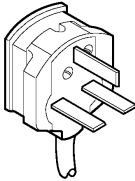
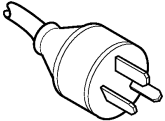
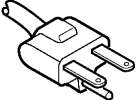
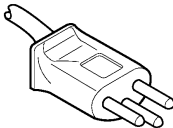
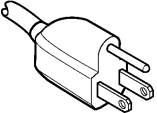
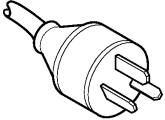
Plug configuration	Normal usage	Option number
	North America 120 V	A0
	Universal Euro 230 V	A1
	United Kingdom 230 V	A2
	Australia 240 V	A3
	North America 240 V	A4
	Switzerland 220 V	A5
	Japan 100 V	A6
	China 240 V	A10
	No power cord supplied.	A99

Standard Accessories

All analyzers in this series are shipped with the accessories listed in Table 7–2.

Table 7–2: Standard accessories

Accessory	Part number
English language user manual	071-1334-XX
English language programmer manual	071-1336-XX
U.S. power cord	161-0104-00
BNC–N adapter	103-0045-XX
Front cover	200-A524-XX

Optional Accessories

You can order the accessories listed in Table 7–3 to use with your analyzer.

Table 7–3: Optional accessories

Accessory	Part number
Japanese language user manual	071-1333-XX
Japanese language programmer manual	071-1335-XX
USB mouse	119-B145-XX
USB keyboard	119-B146-XX
Service manual	071-1337-XX
Accessory bag	016-A330-XX
Preamplifier (20 dB gain to 3 GHz)	650-A900-XX
Rack mount kit (for field conversion)	

Electrical Parts List



Electrical Parts List

The modules that make up this instrument are often a combination of mechanical and electrical subparts. Therefore, all replaceable modules are listed in Section 10, *Mechanical Parts List*. Refer to that section for part numbers when using this manual.

Diagrams

Diagrams

This section contains the following diagrams:

- Block diagram: Shows the modules and functional blocks.
- Interconnect diagrams: Show how the modules connect together.

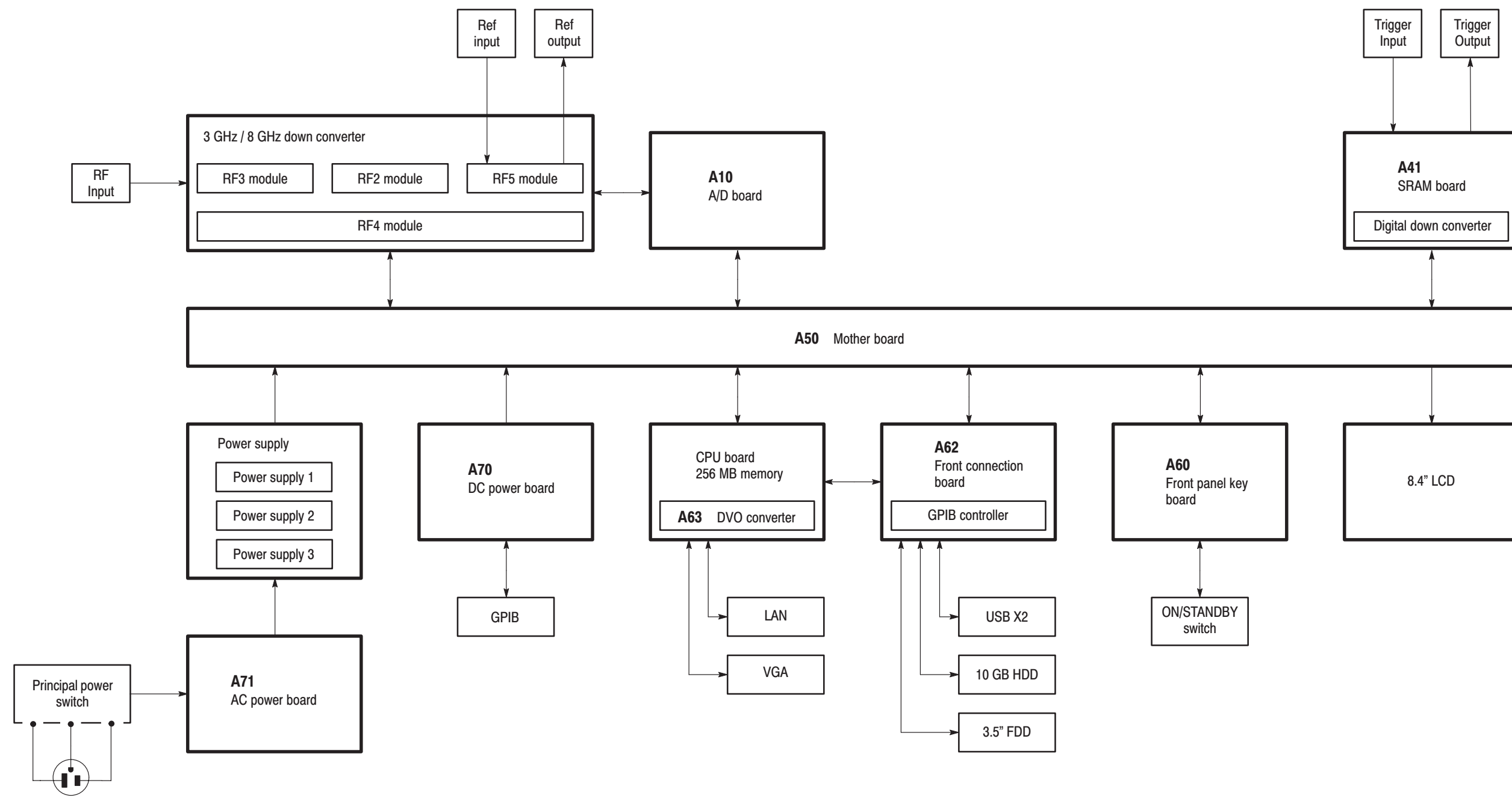

Figure 9-1: Block diagram

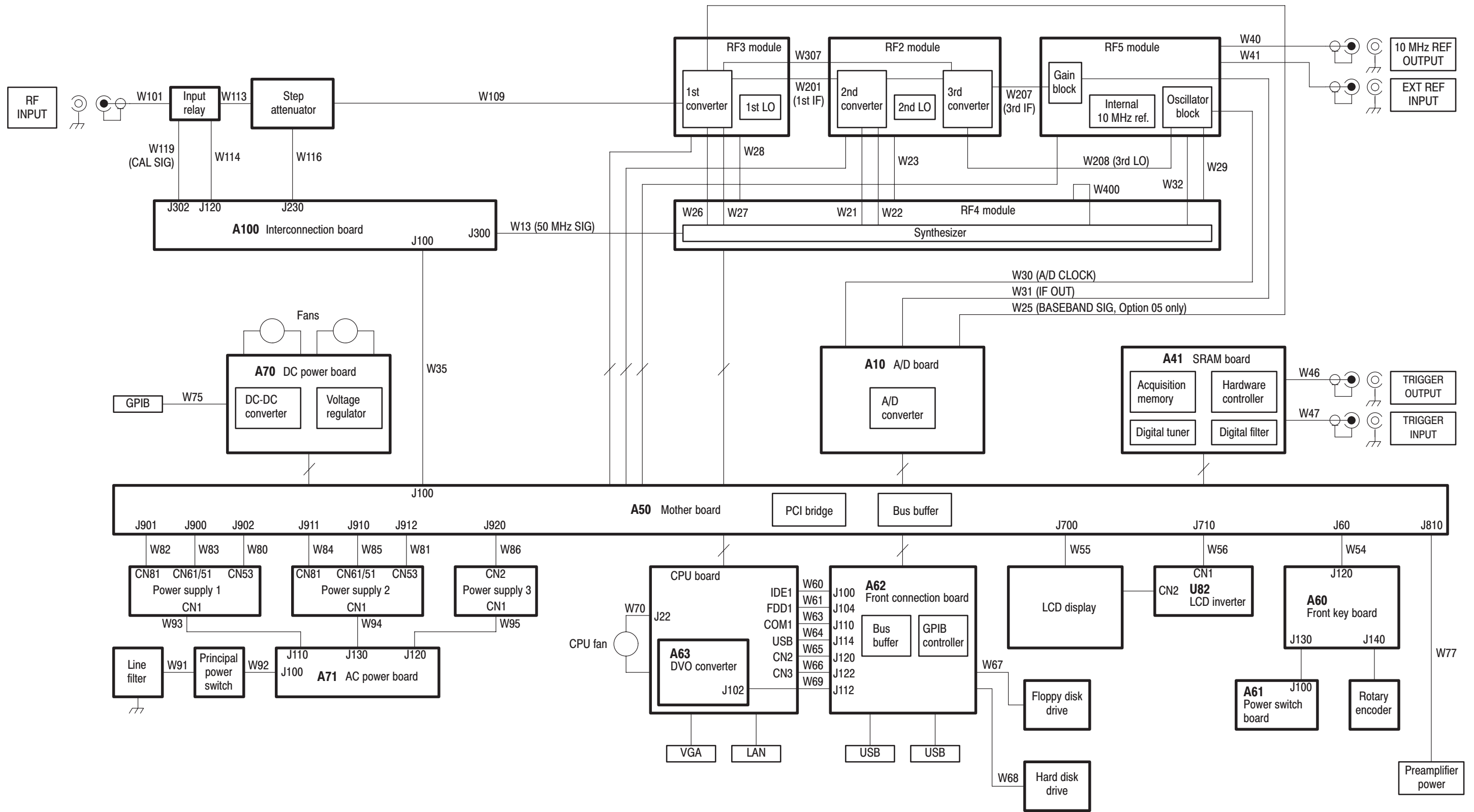

Figure 9-2: Interconnect diagram (RSA2203A)

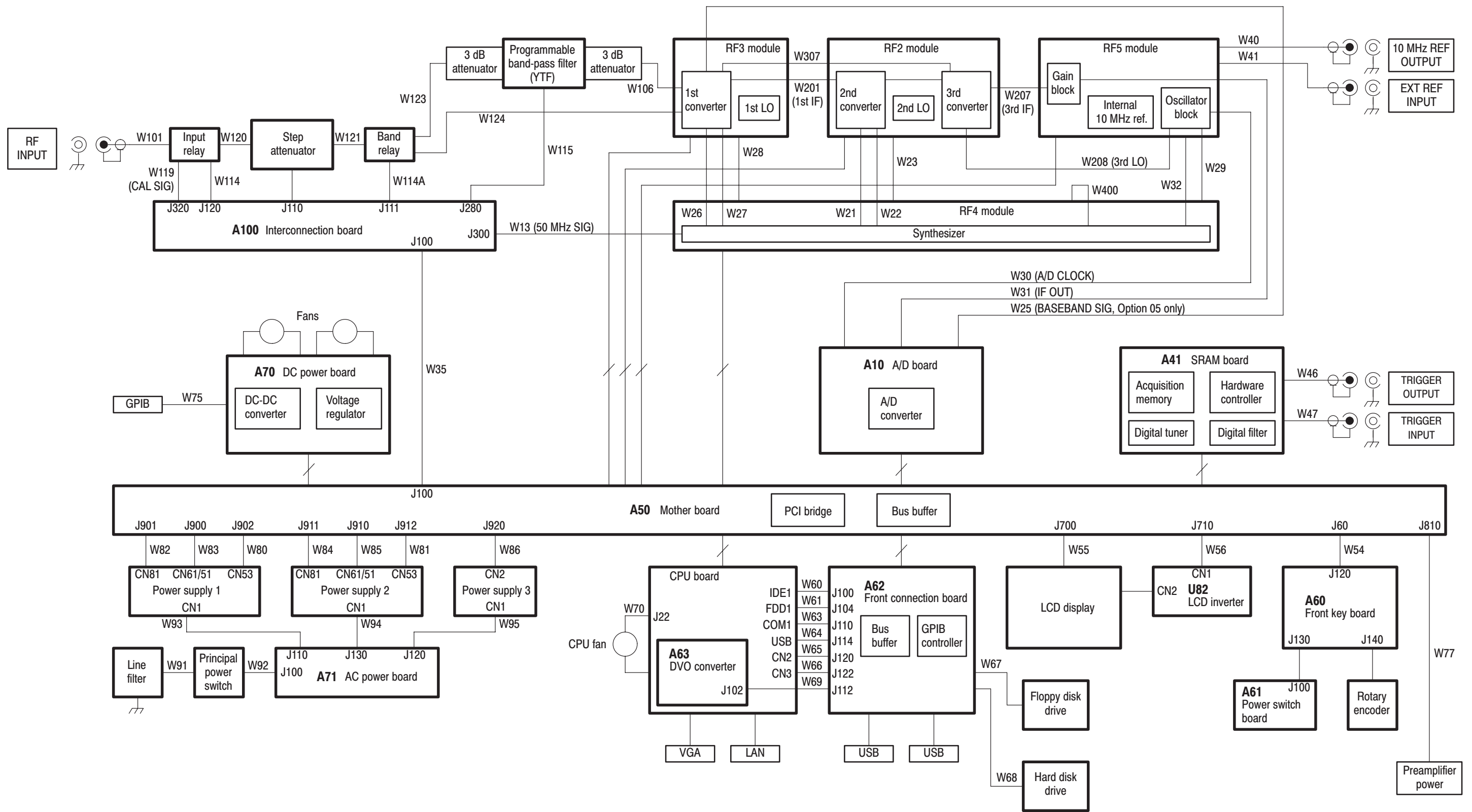

Figure 9-3: Interconnect diagram (RSA2208A)

Mechanical Parts List

Replaceable Parts

This section contains a list of the replaceable modules for the RSA2203A and RSA2208A Real-Time Spectrum Analyzers. Use this list to identify and order replacement parts.

Parts Ordering Information

Replacement parts are available through your local Tektronix field office or representative.

Changes to Tektronix products are sometimes made to accommodate improved components as they become available and to give you the benefit of the latest improvements. Therefore, when ordering parts, it is important to include the following information in your order:

- Part number
- Instrument type or model number
- Instrument serial number
- Instrument modification number, if applicable

If you order a part that has been replaced with a different or improved part, your local Tektronix field office or representative will contact you concerning any change in part number.

Part Number Revision Level

Tektronix part numbers contain two digits that show the revision level of the part. For most parts in this manual, you will find the letters XX in place of the revision level number.



When you order parts, Tektronix will provide you with the most current part for your product type, serial number, and modification (if applicable). At the time of your order, Tektronix will determine the part number revision level needed for your product, based on the information you provide.

Module Servicing Modules can be serviced by selecting one of the following three options. Contact your local Tektronix service center or representative for repair assistance.

Module Exchange. In some cases you may exchange your module for a remanufactured module. These modules cost significantly less than new modules and meet the same factory specifications. For more information about the module exchange program, call 1-800-833-9200. Outside North America, contact a Tektronix sales office or distributor; see the Tektronix web site for a list of offices: www.tektronix.com.

Module Repair and Return. You may ship your module to us for repair, after which we will return it to you.

New Modules. You may purchase replacement modules in the same way as other replacement parts.

Using the Replaceable Parts List

This section contains a list of the mechanical and/or electrical components that are replaceable for the analyzer. Use this list to identify and order replacement parts. The following table describes each column in the parts list.

Parts list column descriptions

Column	Column name	Description
1	Figure & index number	Items in this section are referenced by figure and index numbers to the exploded view illustrations that follow.
2	Tektronix part number	Use this part number when ordering replacement parts from Tektronix.
3 and 4	Serial number	Column three indicates the serial number at which the part was first effective. Column four indicates the serial number at which the part was discontinued. No entries indicates the part is good for all serial numbers.
5	Qty	This indicates the quantity of parts used.
6	Name & description	An item name is separated from the description by a colon (:). Because of space limitations, an item name may sometimes appear as incomplete. Use the U.S. Federal Catalog handbook H6-1 for further item name identification.
7	Mfr. code	This indicates the code of the actual manufacturer of the part.
8	Mfr. Part Number	This indicates the actual manufacturer's or vendor's part number.

Abbreviations Abbreviations conform to American National Standard ANSI Y1.1-1972.

**Mfr. Code to Manufacturer
Cross Index**

The table titled Manufacturers Cross Index shows codes, names, and addresses of manufacturers or vendors of components listed in the parts list.

Manufacturers cross index

Mfr. code	Manufacturer	Address	City, state, zip code
80009	TEKTRONIX, INC.	P.O. BOX 500	BEAVERTON, OR, 97077-0001
S3109	FELLER U.S. CORPORATION	68 VERONICA AVE, UNIT #5	SOMERSET, NJ 08873

Replaceable parts list

Fig. & index number	Tektronix part number	Serial No. effective	Serial No. discont'd	Qty	Name & description	Mfr. code	Mfr. part number
10-1							
-1	200-A524-XX			1	COVER,FRONT:WCA230A/280A	80009	
-2	348-A152-XX			4	PAD,FOOT:GRAY,WCA230A/280A	80009	
-3	211-A039-XX			4	SCREW,MACHINE:M4X14MM L,PNH,STL,ZN PL,CROSS REC, W/FLAT&LOCK WASHER	80009	
-4	348-A150-XX			2	CUSHION,FRONT:GRAL,WCA230A/280A	80009	
-5	384-A223-XX			1	SHAFT,STAND:SST	80009	
-6	437-A013-XX			1	CABINET,ASSY:WCA230A/280A	80009	
-7	437-0508-XX			1	CABINET,ASSY:WCA230A/280A WITH HANDLE AND FOOT	80009	
-8	211-A004-XX			2	SCREW,MACHINE:M4X10MM,PNH,STL,ZN-C,CROSS REC, W/FLAT&LOCK WASHER	80009	
-9	348-A151-XX			4	FOOT,REAR:GRAY,WCA230A/280A	80009	
-10	213-A249-XX			4	SCREW,MACHINE:M4X20 L,PNH,STL,ZN-C,CROSS REC, W/FLAT(MIGAKI)&LOCK WASHER	80009	
-11	367-0247-XX			1	HANDLE,CARRYING:11.54L,PLASTIC	80009	
-12	200-2191-XX			2	CAP,RETAINER:PLASTIC	80009	
-13	348-1110-XX			4	FOOT,CABINET:FRONT	80009	
-14	161-0104-XX			1	CABLE ASSY,PWR(STANDARD ACCESSORY)	80009	

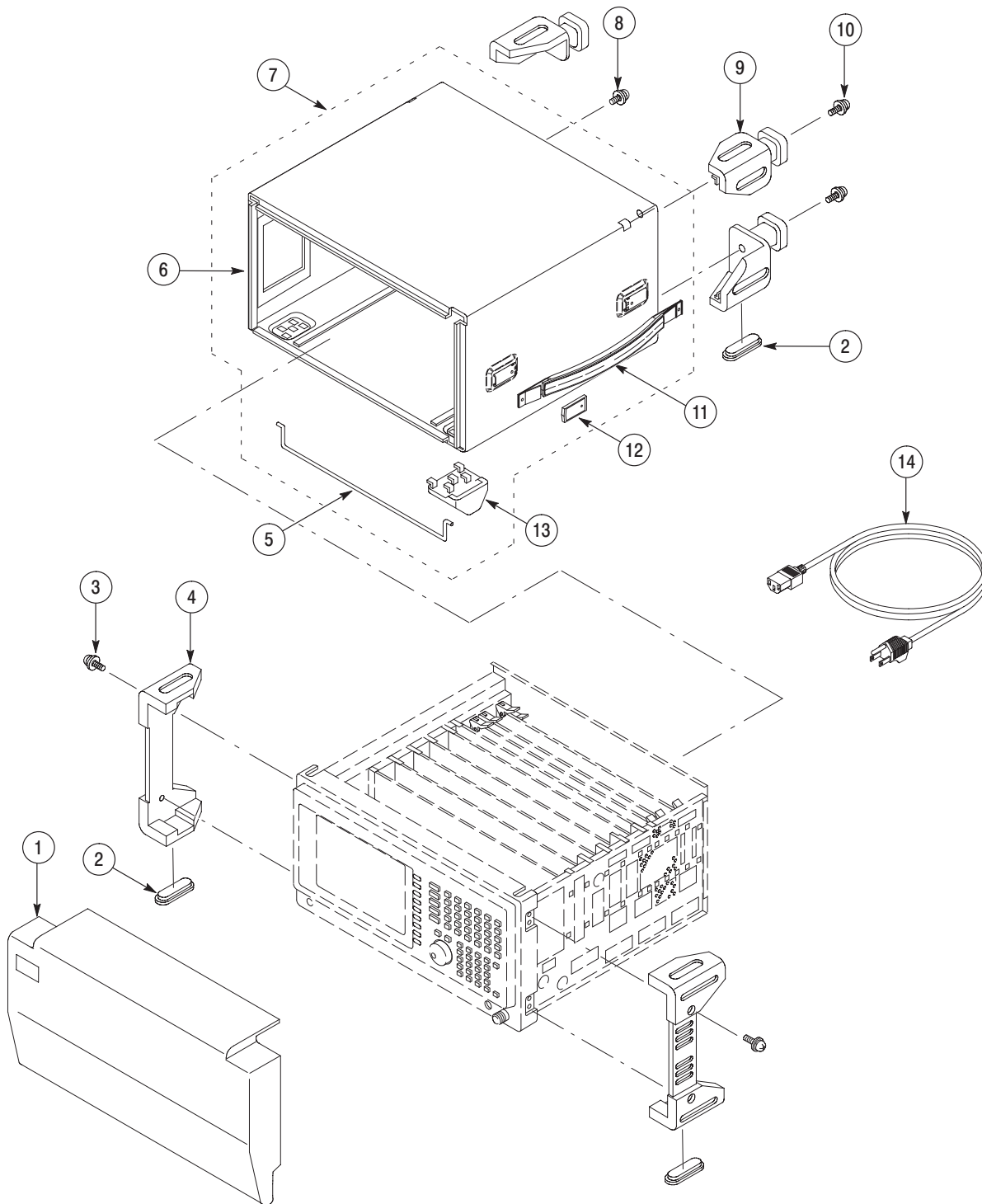

Figure 10-1: External modules

Replaceable parts list

Fig. & index number	Tektronix part number	Serial No. effective	Serial No. discont'd	Qty	Name & description	Mfr. code	Mfr. part number
10-2							
-1	211-0871-XX			1	SCREW,MACHINE:M3X6MM L,PNH,STL,ZN PL,CROSS REC, W/FLAT(7MM OD)&LOCK WASHER	80009	
-2	671-B157-XX			1	CIRCUIT BD ASSY:A61 POWER-SW,389-B159-XX WIRED	80009	
-3	361-A179-XX			1	SPACER,LED:2MM L X 4.5MM OD TPE	80009	
-4	366-A046-XX			1	PUSH BUTTON,POWER:SILVER GRAY,ABS	80009	
-5	174-B995-XX			1	CA ASSY,SP,ELEC:6,AWG26,15CM L,RIBBON, LEMO 6P TO JST 6P,PRE AMP	80009	
-6	210-1039-XX			1	WASHER,LOCK:0.521 ID,INT,0.025 THK,SST	80009	
-7	407-4966-XX			1	BRACKET FRONT:AL,RSA2200A-STD	80009	
-8	671-B156-XX			1	CIRCUIT BD ASSY:A60 FRONT-KB,389-B158-XX WIRED	80009	
-9	211-0871-XX			4	SCREW,MACHINE:M3X6MM L,PNH,STL,ZN PL,CROSS REC, W/FLAT(7MM OD)&LOCK WASHER	80009	
-10	366-A059-XX			1	PUSH BUTTON:RUBBER SWITCH,SET,SILICON RUBBER	80009	
-11	260-2497-XX			1	SWITCH,ROTARY:ENCODR,5VDC,70MA,INCREMENTAL W/9CM L CABLE ASSY	80009	
-12	378-A050-XX			1	FILTER,LCD:ACRYL,WCA200,191.6MM X 149.5MM X 1.2MM T	80009	
-13	200-A523-XX			1	BEZEL,FRONT:WCA230A/280A	80009	
-14	333-A464-XX			1	PANEL,FRONT:KEYBOARD,WCA230A/280A	80009	
-15	333-4469-XX			1	PANEL,FRONT:LOW,AL,RSA2203A/2208A	80009	
	333-A466-XX				PANEL,FRONT:LOW,WCA230A/280A (OPTION 2A ONLY)		
-16	366-A057-XX			1	SHELL,KNOB:SILVER GRAY,38MM OD X 11MM H,ABS/PC	80009	
-17	366-A056-XX			1	KNOB,ASSY:6MM ID X 38MM OD X 11MM H,SILVER GRAY, ABS	80009	
-18	335-1070-XX			1	MARKER,IDENT:MKD RSA2203A,POLYCARBONATE	80009	
	335-1071-XX				MARKER,IDENT:MKD RSA2208A,POLYCARBONATE		
	335-1085-XX				MARKER,IDENT:MKD RSA2203A,OP-05,POLYCARBONATE (OP-05)		
	335-1086-XX				MARKER,IDENT:MKD RSA2208A,OP-05,POLYCARBONATE (OP-05)		
-19	174-B982-XX			1	CA ASSY,SP,ELEC:16,26AWG,15CM,RIBBON,W/HLDR	80009	
-20	174-B981-XX			1	CA ASSY,SP,ELEC:5,26AWG,27CM,RIBBON,W/HLDR	80009	

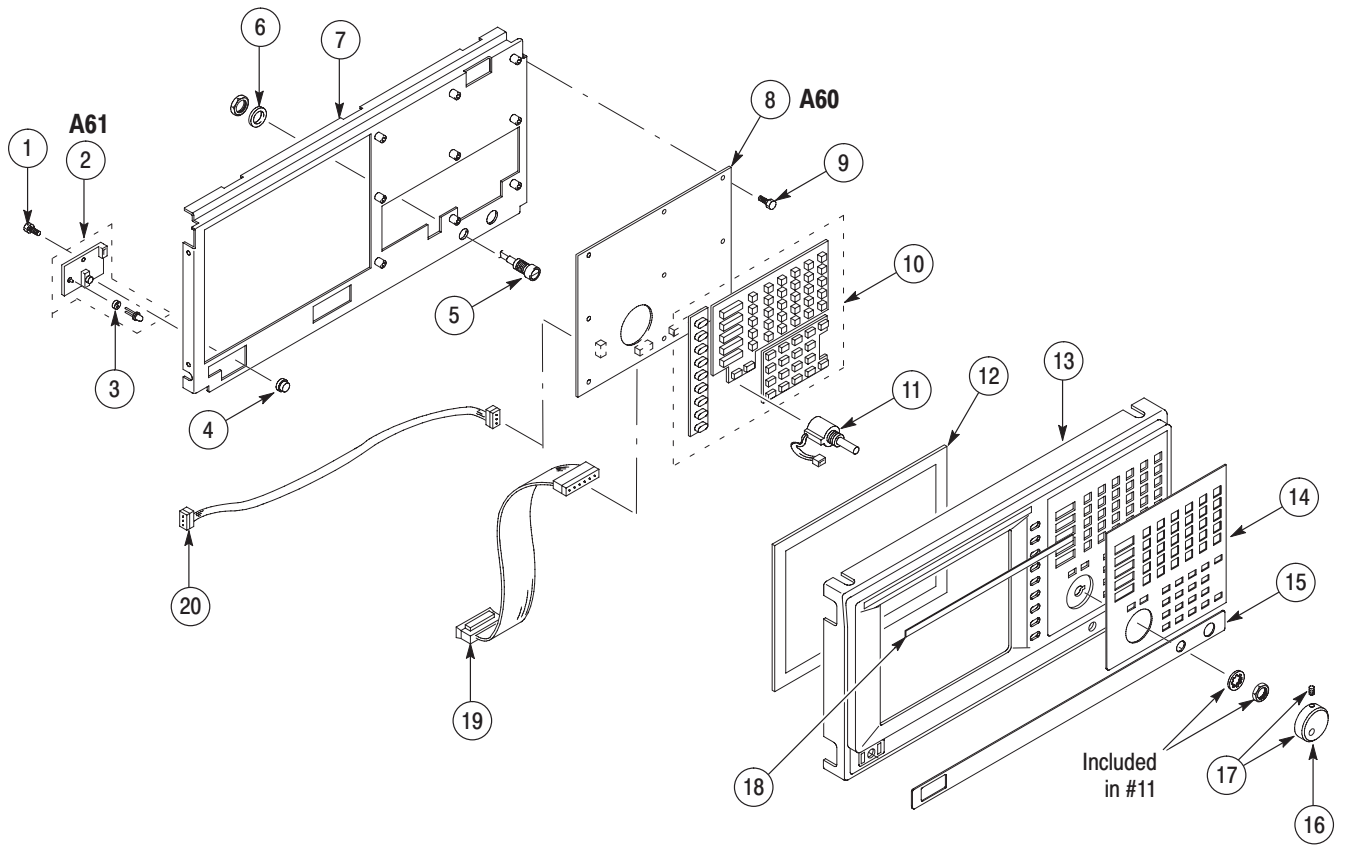

Figure 10-2: Front-panel assembly - 1

Replaceable parts list

Fig. & index number	Tektronix part number	Serial No. effective	Serial No. discont'd	Qty	Name & description	Mfr. code	Mfr. part number
10-3							
-1	211-0945-XX			4	SCREW,MACHINE:M4X8MM L,STL,ZN-C,CROSS REC	80009	
-2	348-1433-XX			130 CM	SHLD GASKET,ELEC:MESH TYPE,2.5MM OD, SI SPONGE CORE	80009	
-3	407-4965-XX			1	BRACKET:FRONT SUB PANEL,RSA2200A-STD	80009	
-4	343-1286-XX			2	CLAMP,CABLE:6.8MM ID,NYLON	80009	
-5	211-A004-XX			10	SCREW,MACHINE:M4X10MM L,PNH,STL,ZN-C,CROSS REC W/FLAT&LOCK WASHER	80009	
-6	343-1644-XX			2	CLAMP,CABLE:CLIP LOCKING WIRE,NYLON	80009	
-7	348-1644-XX			38 CM	SHIELD GASKET,ELEC:CONDUCTIVE URETHANE FOAM, W/ADHESIVE TAPE	80009	
-8	119-B125-XX			1	DISPLY MONITOR:8.4INCH,LCD,TFT,800X600,SVGA,3.3V, W BACK LIGHT	80009	
-9	119-B126-XX			1	INVERTER UNIT:COLD-CATHODE TUBE INVERTER FOR LTM08C351,12VDC,0.9A	80009	
-10	174-B984-XX			1	CA ASSY,SP,ELEC:8,26AWG,13CM L,W/HLDR	80009	
-11	211-0871-XX			2	SCREW,MACHINE:M3X6MM L,PNH,STL,ZN PL,CROSS REC, W/FLAT(7MM OD)&LOCK WASHER	80009	
-12	131-6608-XX			1	CONN,RF:N TO SMA,50OHM,PANEL MOUNT	80009	
-13	211-1028-XX			3	SCREW,MACHINE:M4X8MM L,PNH,STL,ZN-C PL, CROSS REC,W/FLAT&LOCK WASHER	80009	
-14	386-A857-XX			1	PLATE:N-CONNECTOR	80009	
-15	348-A116-XX			63 CM	SHLD GSKT ELEC:CONDUCTIVE URETHANE FOAM, 1MM X 3MM,W/ADHESIVE	80009	
-16	211-0751-XX			4	SCREW,MACHINE:M3X8MM L,PNH,STL,ZN-C, CROSS REC,W/FLAT&LOCK WASHERS	80009	

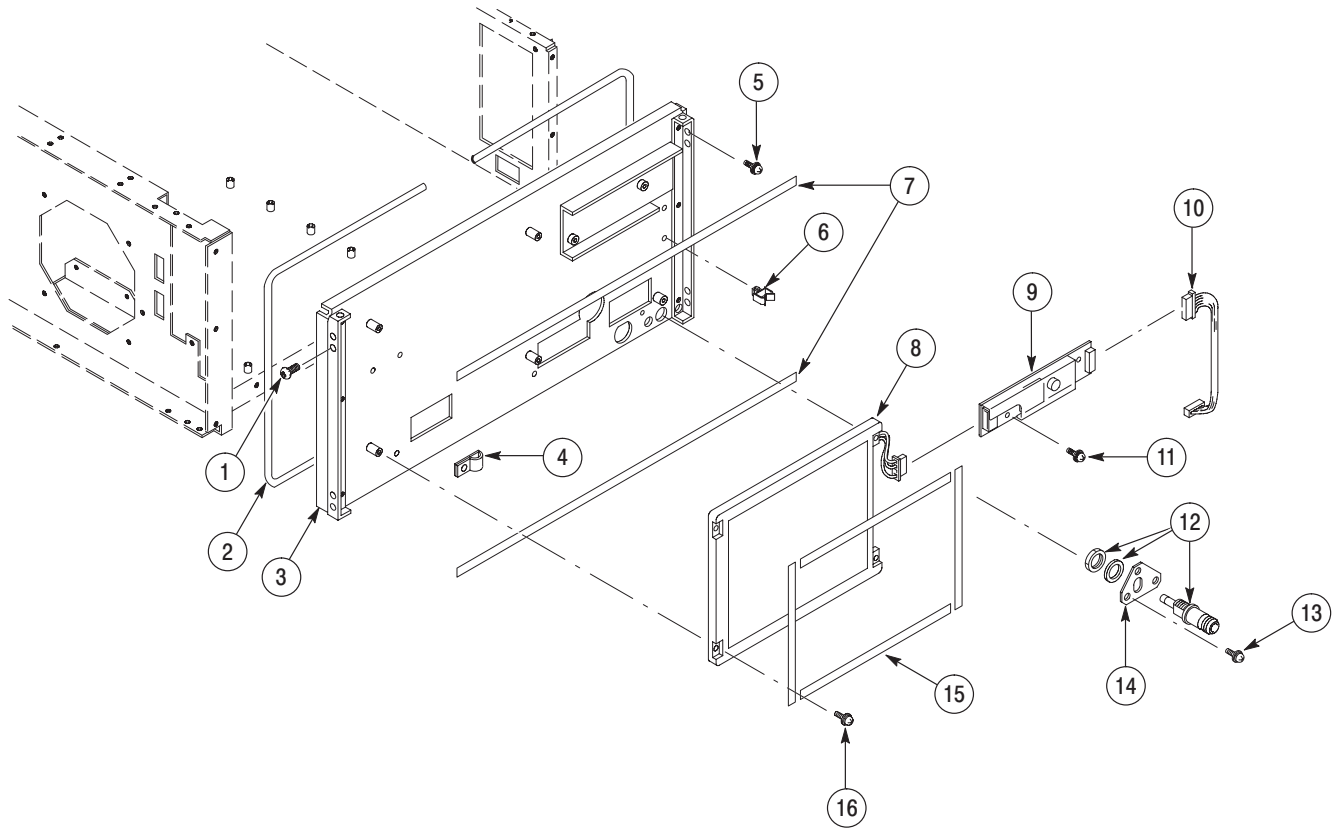

Figure 10-3: Front-panel assembly - 2

Replaceable parts list

Fig. & index number	Tektronix part number	Serial No. effective	Serial No. discont'd	Qty	Name & description	Mfr. Code	Mfr. part number
10-4							
-1	211-1028-XX			8	SCREW,MACHINE;M4X8MM L,PNH,STL,MFZN-C, CROSS REC W/FLAT&LOCK WASHER	80009	
-2	119-B174-XX			1	MODULE,RF:DOWNCONVERTER,GAIN BLOCK, RSA230&RSA280,RF5	80009	
	119-B173-XX			1	MODULE,RF:DOWNCONVERTER,GAIN BLOCK, WCA230A&WCA280A,RF5 (OPTION 10 ONLY)	80009	
-3	119-B172-XX			1	MODULE,RF:DOWNCONVERTER,RF4,SYNTHESIZER, WCA280A&WCA230A	80009	
-4	119-B170-XX			1	MODULE,RF:DOWNCONVERTER,1ST,RSA280,RF3 (RSA2208A)	80009	
	119-B171-XX			1	MODULE,RF:DOWNCONVERTER,1ST,RSA230,RF3 (RSA2203A)	80009	
-5	119-B166-XX			1	MODULE,RF:DOWNCONVERTER,2ND&3RD,RSA280,RF2 (RSA2208A)	80009	
	119-B167-XX			1	MODULE,RF:DOWNCONVERTER,2ND&3RD,RSA230,RF2 (RSA2203A)	80009	

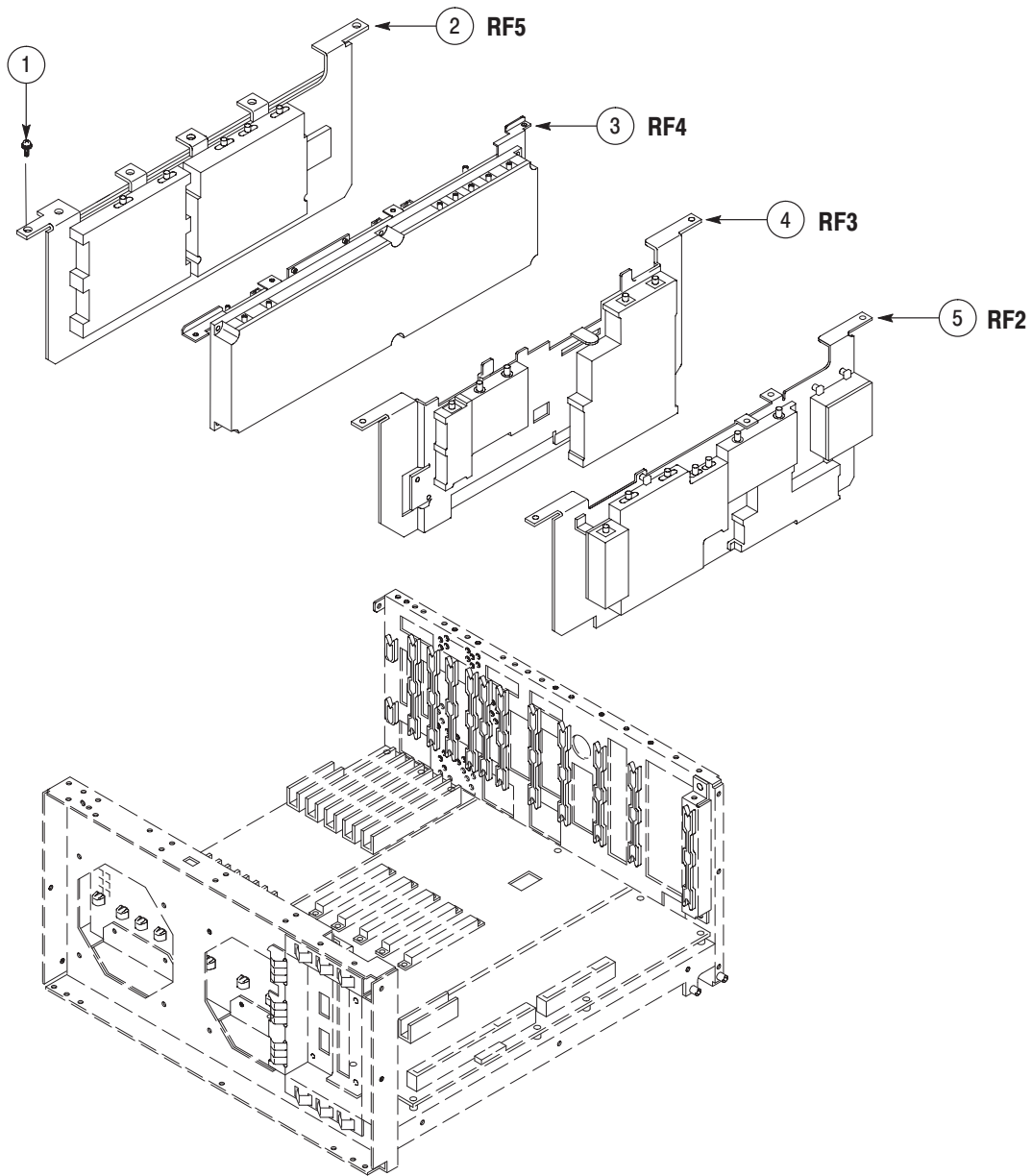

Figure 10-4: RF modules

Replaceable parts list

Fig. & index number	Tektronix part number	Serial No. effective	Serial No. discont'd	Qty	Name & description	Mfr. code	Mfr. part number
10-5							
-1	211-1028-XX			2	SCREW,MACHINE:M4X8MM L,PNH,STL,ZN-C PL, CROSS REC,W/FLAT&LOCK WASHER	80009	
-2	343-1644-XX			2	CLAMP,CABLE:CLIP LOCKING WIRE,NYLON	80009	
-3	348-A120-XX			4	GASKET SHIELD:CONDUCTIVE URETHAN FOAM, 2MM X 4MM,W/ADHESIVE	80009	
-4	344-0472-XX			2	BUSHING:BUSHING,NYLON,GRAY	80009	
-5	211-0871-XX			2	SCREW,MACHINE:M3X6MM L,PNH,STL,MFZN-C, CROSS REC W/FLAT&LOCK WASHER	80009	
-6	211-1028-XX			2	SCREW,MACHINE:M4X8MM L,PNH,STL,ZN-C PL, CROSS REC,W/FLAT&LOCK WASHER	80009	
-7	407-A691-XX			1	BRACKET,SUPPORT:DIGITAL BOARD	80009	
-8	351-A165-XX			3	GUIDE,CKT BD:NYLON	80009	
-9	407-A684-XX			1	BRACKET,SUPPORT:REAR	80009	
-10	671-B159-XX			1	CIRCUIT BD ASSY: A70 DC-POWER,389-B161-XX WIRED	80009	
-11	671-B163-XX			1	CIRCUIT BD ASSY:A41 SRAM,389-B165-XX WIRED	80009	
-12	671-B210-XX			1	CIRCUIT BD ASSY:A10 AD,RSA200 STD,389-B160-XX WIRED	80009	
-13	211-1028-XX			2	SCREW,MACHINE:M4X8MM L,PNH,STL,ZN-C PL, CROSS REC,W/FLAT&LOCK WASHER	80009	
-14	407-A682-XX			1	BRACKET,SHIELD:DIGITAL BOARD	80009	
-15	211-0871-XX			5	SCREW,MACHINE:M3X6MM L,PNH,STL,MFZN-C, CROSS REC W/FLAT&LOCK WASHER	80009	
-16	348-1276-XX			32 CM	GASKET,SHIELD:CONDUCTIVE FOAM STRIP, 3.3MM X 4.8MM,W/ADHESIVE TAPE,1M L	80009	
-17	174-B983-XX			1	CA ASSY,SP,ELEC:30,30AWG,20CM,W/HLDR,W SHIELD, DF19-30S-1C CONN	80009	
-18	671-B269-XX			1	CIRCUIT BD ASSY:A50 MOTHER,389-B165-XX WIRED	80009	
-19	211-0871-XX			25	SCREW,MACHINE:M3X12MM L,PNH,STL,ZN-CM1, W/K-PLAIN&SPLIT WASHER	80009	
-20	343-1644-XX			2	CLAMP,CABLE:CLIP LOCKING WIRE,NYLON	80009	

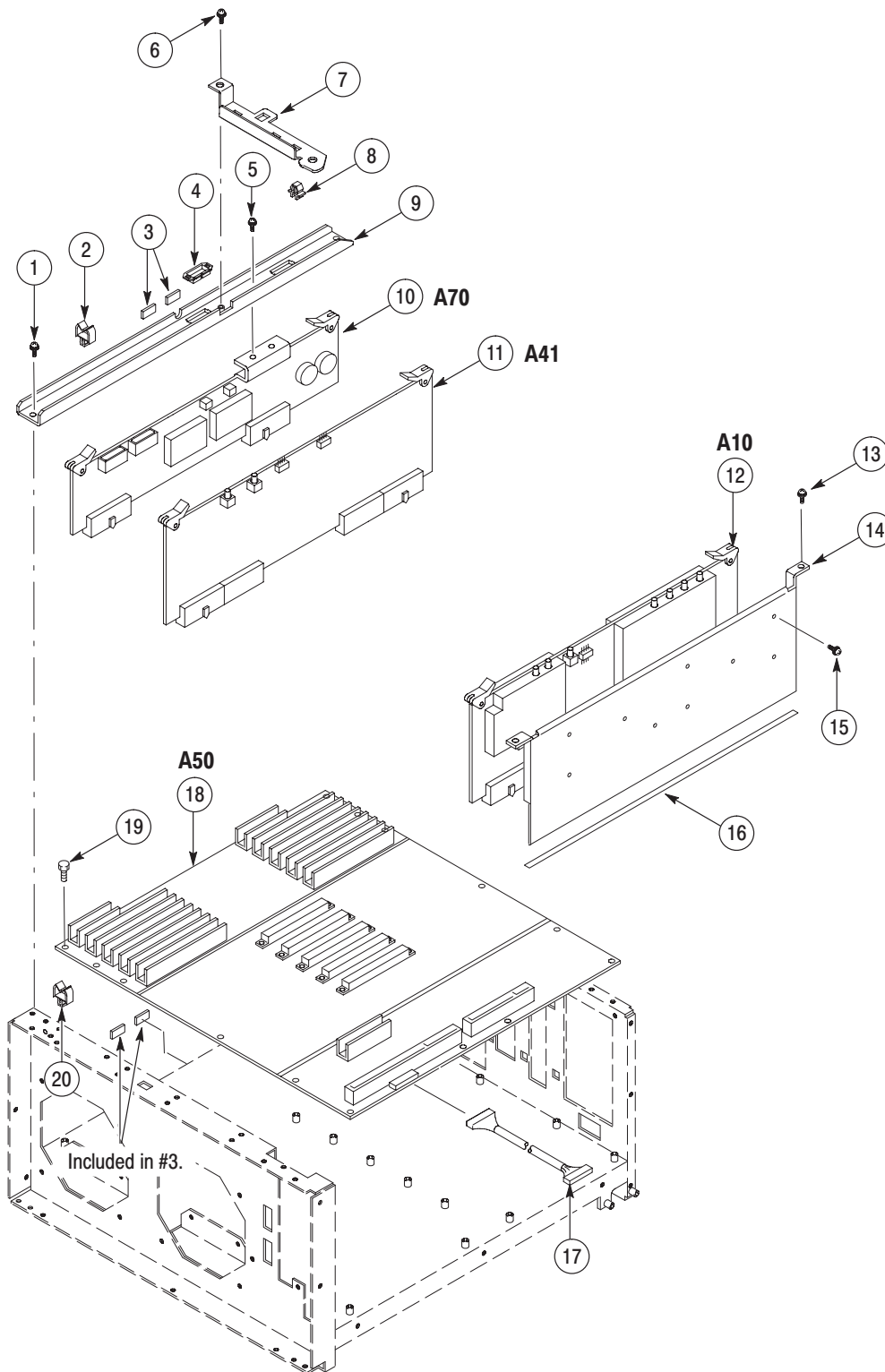

Figure 10-5: Mother board and its daughter boards - 1

Replaceable parts list

Fig. & index number	Tektronix part number	Serial No. effective	Serial No. discont'd	Qty	Name & description	Mfr. code	Mfr. part number
10-6							
-1	211-1028-XX			2	SCREW,MACHINE:M4X8MM L,PNH,STL,ZN-C PL, CROSS REC,W/FLAT&LOCK WASHER	80009	
-2	407-A683-XX			1	BRACKET,SHIELD:PC BOARD	80009	
-3	348-1276-XX			32 CM	GASKET,SHIELD:CONDUCTIVE FOAM STRIP, 3.3MM X 4.8MM,W/ADHESIVE TAPE,1M L	80009	
-4	211-0871-XX			2	SCREW,MACHINE:M3X6MM L,PNH,STL,MFZN-C, CROSS REC W/FLAT&LOCK WASHER	80009	
-5	211-0871-XX			2	SCREW,MACHINE:M3X6MM L,PNH,STL,MFZN-C, CROSS REC W/FLAT&LOCK WASHER	80009	
-6	211-0871-XX			2	SCREW,MACHINE:M3X6MM L,PNH,STL,MFZN-C, CROSS REC W/FLAT&LOCK WASHER	80009	
-7	407-4988-XX			1	BRACKET,STOPPER:CPU BOARD	80009	
-8	351-A165-XX			1	GUIDE,CKT BD:NYLON	80009	
-9	407-4987-XX			1	BRACKET,SUPPORT:MEMORY	80009	
-10	211-A171-XX			1	SCREW,MACHINE:M3X12MM L,PNH,STL,ZN-CM1, W/K-PLAIN&SPLIT WASHER	80009	
-12	211-0871-XX			1	SCREW,MACHINE:M3X6MM L,PNH,STL,MFZN-C, CROSS REC W/FLAT&LOCK WASHER	80009	
-12	407-A690-XX			1	BRACKET:STOPPER,PC BOARD	80009	
-13	119-6925-XX			1	CKT BD ASSY:CPU BD ASSY1196924XX + MEMORY119B117XX + A63 BD(6715800XX) + MECHA PARTS	80009	

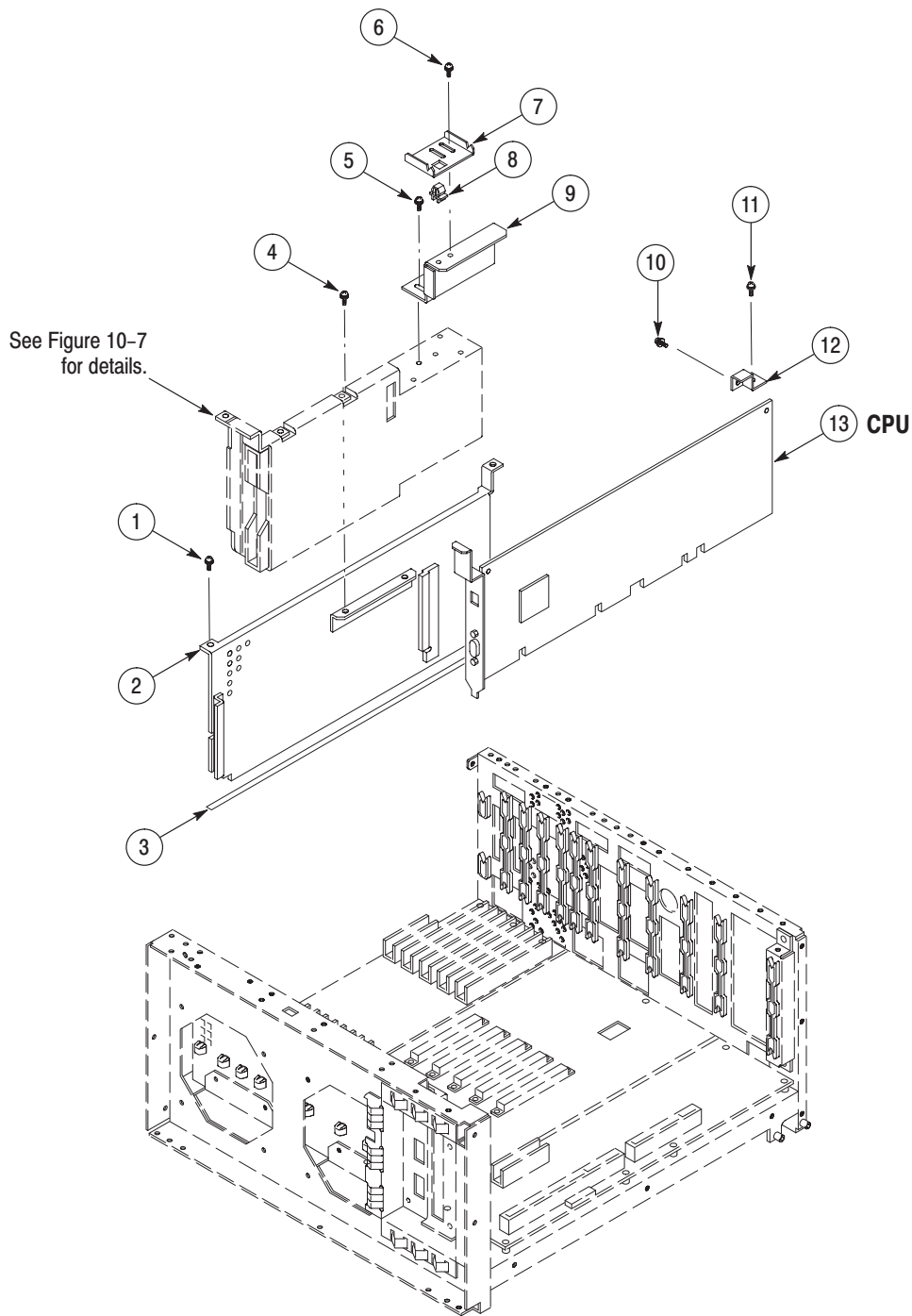

Figure 10-6: Mother board and its daughter boards - 2

Replaceable parts list

Fig. & index number	Tektronix part number	Serial No. effective	Serial No. discont'd	Qty	Name & description	Mfr. code	Mfr. part number
10-7							
-1	119-6944-XX			1	HDD UNIT:2.5",IDE I/F,O/S AND F/W INSTALLED (RSA2203A)	80009	
	119-6945-XX			1	HDD UNIT:2.5",IDE I/F,O/S AND F/W INSTALLED (RSA2208A)		
-2	348-A144-XX			4	DUMPER:DUMPER	80009	
-3	129-A593-XX			4	SUPPORT:PS-308	80009	
-4	210-A014-XX			4	WASHER,PLAIN:#6,BRS NI PL	80009	
-5	210-0949-XX			4	WASHER,FLAT:0.141IDX0.5ODX0.062,BRS NP	80009	
-6	211-A170-XX			4	SCREW,MACHINE:M3X15MM L,PNH,STL,ZN-CM1, W/M-PLAIN&SPLIT WASHER	80009	
-7	348-1656-XX			2	GASKET,SHIELD:CONDUCTIVE URETHAN FOAM, W/ADHESIVE TAPE BACKSIDE	80009	
				CM			
-8	211-A275-XX			4	SCREW,MACHINE:M2.6X5MM L,PNH,STL,ZN-C, CROSS REC,W/K-PLAIN&LOCK WASHER	80009	
-9	407-A733-XX			4	BRACKET,STOPPER:GASKET,SIDE,R,AL	80009	
-10	348-1472-XX			7	GASKET:ELEC,SHIELD GASKET,CONDUCTIVE FOAMSTRIP, W/ADHESIVE TAPE,1M L	80009	
				CM			
-11	119-5953-XX			1	FLOPPY DISK DRIVE:3.5INCH 3-MODE W/INTERFACE	80009	
-12	671-5799-XX			1	CIRCUIT BD ASSY:A62 FRONT-CON,3893564XX WIRED, RSA3300	80009	
-13	211-0751-XX			4	SCREW,MACHINE:M3X8MM L,PNH,STL,ZN-C,CROSS REC, W/FLAT&LOCK WASHERS	80009	
-14	407-A731-XX			1	BRACKET,SHIELD:A62,AL	80009	
-15	348-1788-XX			8	GASKET,SHIELD:CONDUCTIVE URETHAN FOAM, 3MM X 4MM,W/CONDUCTIVE ADHESIVE	80009	
				CM			
-16	348-1656-XX			4	GASKET,SHIELD:CONDUCTIVE URETHAN FOAM, W/ADHESIVE TAPE BACKSIDE	80009	
				CM			
-17	174-4940-XX			1	CA ASSY,SP,ELEC:2,26AWG,15CM L,RIBBON,W/HLDR FCN-723J002/1&PHR-2	80009	
-18	174-4941-XX			1	CA ASSY,SP,ELEC:20,28AWG,20CM L,TWIST PAIR WIRE, MORE THAN 25 TWIST,W/HLDR BOTH DF13-20DS-1.25C	80009	
-19	174-4938-XX			1	CA ASSY,SP,ELEC: 10,26AWG,10CM L,W/HOLDER, HLDR 10P TO 10P	80009	
-20	174-B987-XX			1	CA ASSY,SP,ELEC:10,28AWG,7CM L,FLAT,W/TAG,2.54MM	80009	
-21	174-B986-XX			1	CA ASSY,SP,ELEC:34,28AWG,13CM L,FLAT,W/TAG,2.54MM	80009	
-22	174-4939-XX			1	CA ASSY,SP,ELEC:3,26AWG,15CM L,W/HLDR FCN-723J003/1&PHR-3	80009	
-23	174-4912-XX			1	CA ASSY,SP,ELEC:FLAT,40 COND,28AWG,30CM L, 2X20 HEADER CONN BOTH,KEY POSITION #20	80009	
-24	174-B993-XX			1	CA ASSY,SP,ELEC;44,28AWG,8CM L,2MM PITCH, NORMAL ASSY	80009	
-25	174-B991-XX			1	CA ASSY,SP,ELEC:26,1MM PITCH,8CM L,FFC,REVERSE	80009	

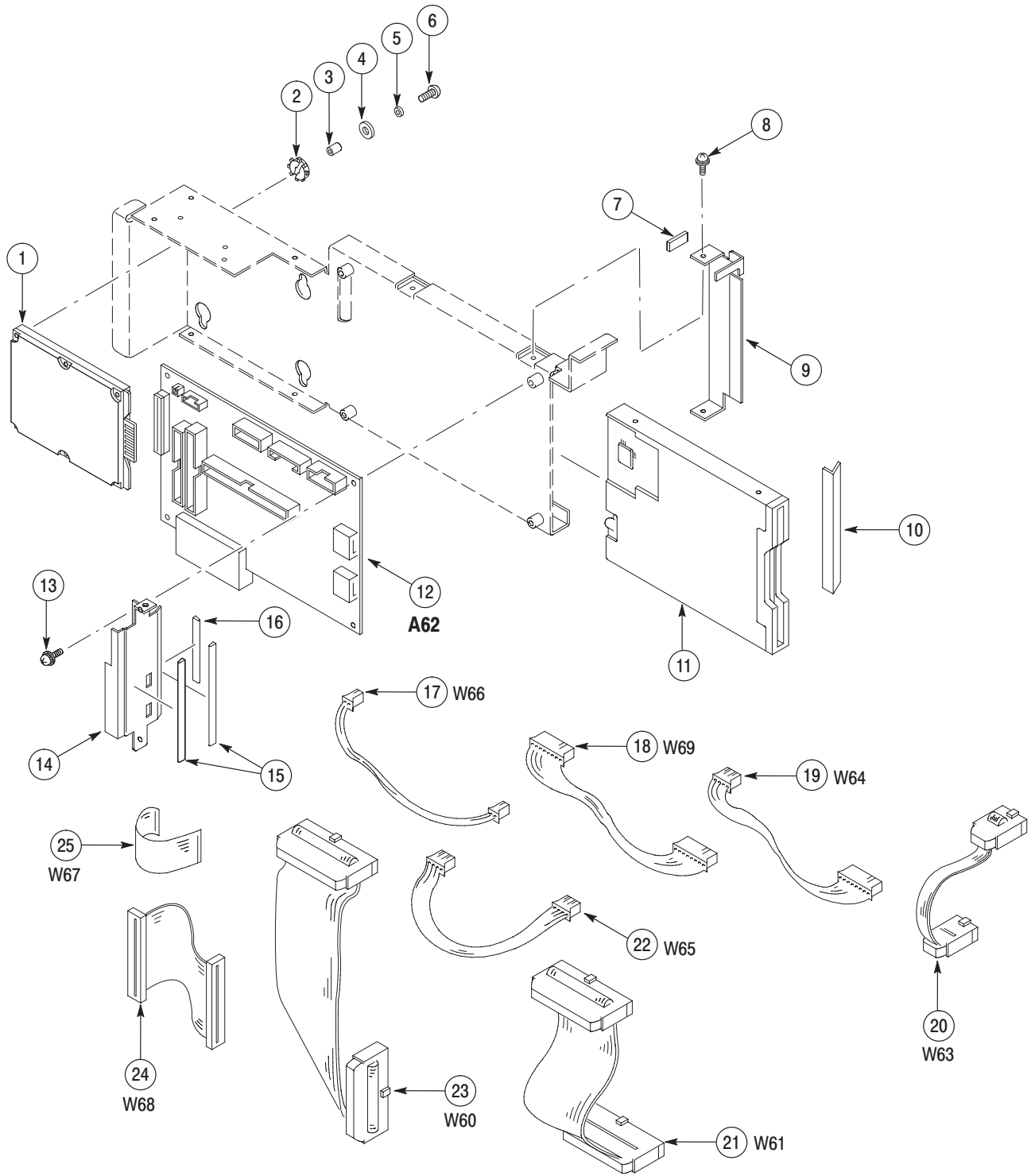

Figure 10-7: Disk modules

Replaceable parts list

Fig. & index number	Tektronix part number	Serial No. effective	Serial No. discont'd	Qty	Name & description	Mfr. code	Mfr. part number
10-8							
-1	211-0871-XX			8	SCREW,MACHINE:M3X6MM L,PNH,STL,MFZN-C, CROSS REC W/FLAT&LOCK WASHER	80009	
-2	119-B128-XX			1	POWER SUPPLY:IN 85-265VAC,47-63HZ,OUT 5V15A, ±12V/15V4A,24V2A,W/REMOTE CONTROL	80009	
-3	119-B127-XX			1	POWER SUPPLY:IN 85-265VAC,47-63HZ,OUT 5V15A, ±12V/15V4A,3.3V10A,W/REMOTE CONTROL	80009	
-4	342-A169-XX			1	INSULATOR:POWER SUPPLY	80009	
-5	211-0871-XX			4	SCREW,MACHINE:M3X6MM L,PNH,STL,MFZN-C, CROSS REC W/FLAT&LOCK WASHER	80009	
-6	407-A702-XX			1	BRACKET,SHIELD:POWER SUPPLY	80009	
-7	174-B997-XX			2	CA ASSY,SP,ELEC:2,26AWG,7CM L,RIBBON,W/HLDR, ON/OFF	80009	
-8	174-B999-XX			2	CA ASSY,SP,ELEC:6,18AWG,7CM L,W/HOLDER, HLDR 6P TO 8P	80009	
-9	174-C001-XX			2	CA ASSY,SP,ELEC:7,18AWG,7CM L,W/HOLDER, HLDR 8P TO 3P+6P	80009	
-10	174-C002-XX			1	CA ASSY,SP,ELEC:8,26AWG,12CM L,RIBBON,W/HOLDER	80009	
-11	343-1644-XX			2	CLAMP,CABLE:CLIP LOCKING WIRE,NYLON	80009	
-12	671-B166-XX			1	CIRCUIT BD ASSY:A71 AC-POWER,389-B168-XX WIRED	80009	
-13	211-0871-XX			2	SCREW,MACHINE:M3X6MM L,PNH,STL,MFZN-C, CROSS REC W/FLAT&LOCK WASHER	80009	
-14	211-0871-XX			4	SCREW,MACHINE:M3X6MM L,PNH,STL,MFZN-C, CROSS REC W/FLAT&LOCK WASHER	80009	
-15	119-B058-10			1	POWER SUPPLY:IN 85-264VAC,OUT +5V/2A,+15V/0.3A, -15V/0.2A,WITHOUT COVER	80009	
-16	260-2740-XX			1	SWITCH,ROCKER:DPST250VAC,10A W/I-O MKD	80009	
-17	195-3990-XX			1	LEAD,ELECTRICAL:AWG18,100MM L,5-4,W/LUG	80009	
-18	211-1028-XX			1	SCREW,MACHINE:M4X8MM L,PNH,STL,ZN-C PL, CROSS REC,W/FLAT&LOCK WASHER	80009	
-19	119-2683-XX			1	FILTER,RFI:6A,250VAC,50/60HZ,LEAK=0.4MA, DCRES=0.1OHM	80009	
-20	211-1040-XX			2	SCREW,MACHINE:M3X8MM L,FLH,STL,ZN-C,CROSS REC	80009	
-21	174-C003-XX			1	CA ASSY,SP,ELEC:2,18AWG,10CM L, W/FASTON BOTH ENDS,W/TUBE	80009	
-22	174-C005-XX			1	CA ASSY,SP,ELEC:2,18AWG,15CM L,W/HOLDER, HLDR 5P TO 3P	80009	
-23	174-C004-XX			1	CA ASSY,SP,ELEC:2,18AWG,13CM L, W/FASTON TO HLDR 3P,W/TUBE	80009	
-24	174-C005-XX			1	CA ASSY,SP,ELEC:2,18AWG,15CM L,W/HOLDER, HLDR 5P TO 3P	80009	
-25	174-C006-XX			1	CA ASSY,SP,ELEC:2,18AWG,9CM L,W/HOLDER, HLDR 5P TO 3P	80009	

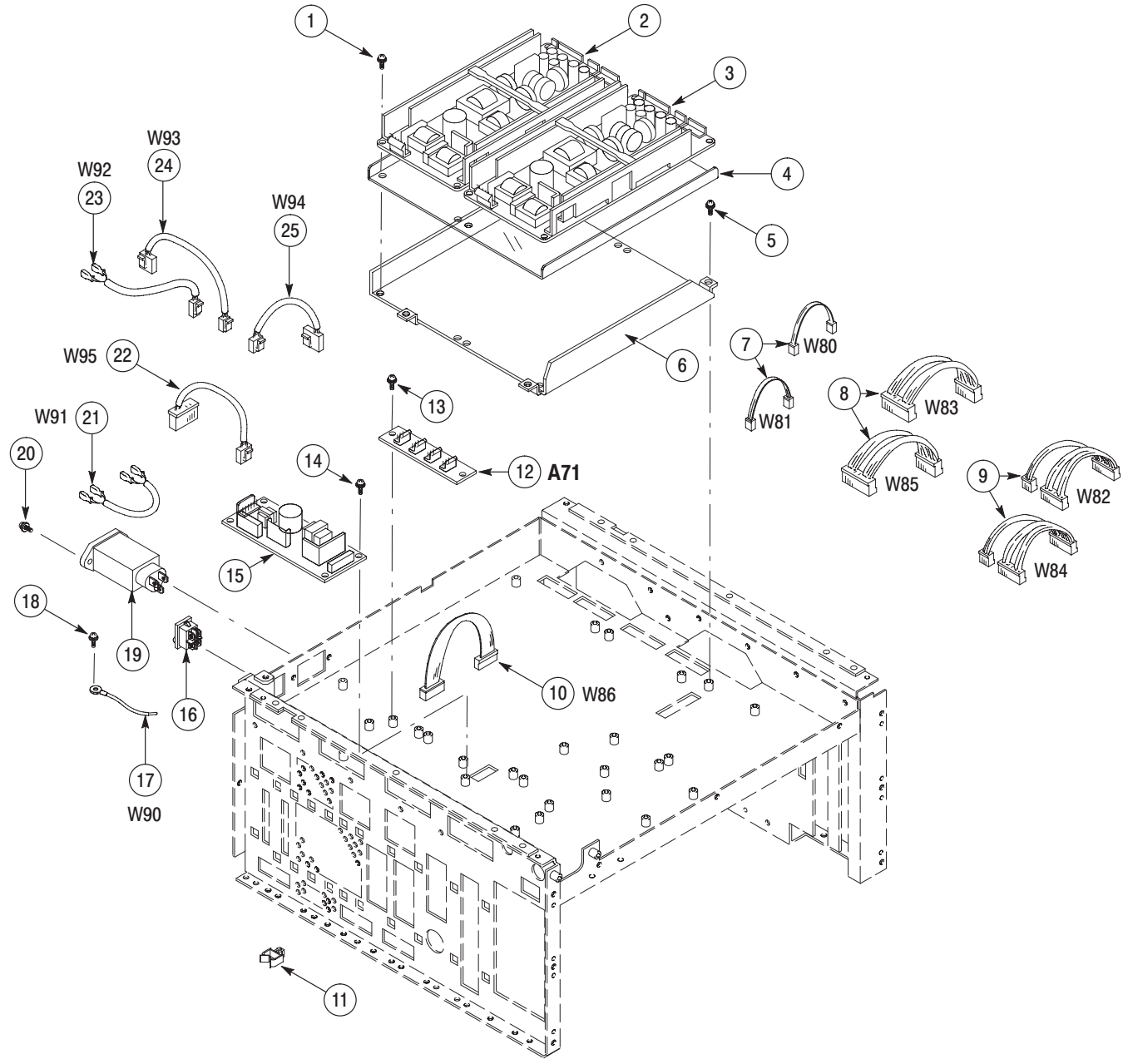

Figure 10-8: Bottom modules - Power supply

Replaceable parts list

Fig. & index number	Tektronix part number	Serial No. effective	Serial No. discont'd	Qty	Name & description	Mfr. code	Mfr. part number
10-9					FOR RSA2203A ONLY		
-1	211-A152-XX			4	SCREW,MACHINE;M2.5X8MM L,STL,PNH,NI PL, CROSS RESS,W/PLAIN&SPLIT WASHER	80009	
-2	119-B180-XX			1	MODULE,RF:DOWN CONVERTER,STEP ATT,WCA230A/280A	80009	
-3	174-C013-XX			1	CABLE ASSY,RF:50OHM,COAX,25CM L,1.5D-QEW, SMB-L TO SMA-L	80009	
-4	174-B956-XX			1	CA ASSY,RF:50OHM,SEMI-RIGID,W113,SW TO STEP ATT	80009	
-5	174-B944-XX			1	CA ASSY,RF:50OHM,SEMI-RIGID,0.085IN,SMA-SMA,W101, WCA280A,WAKA SEISAKUSHO	80009	
-6	211-A273-XX			2	SCREW,MACHINE:M2.5X18 L,PNH,STL,NI PL,CROSS REC, W/FLAT(KOGATA)&LOCK WASHER	80009	
-7	148-A079-XX			1	RELAY,ARMATURE;SPDT,SINGLE SIDE STABLE; RF COAXIAL,18GHZ,COIL 12VDC,70MA,1.53H X 1.34W X 0.52D;ARD10012C03,MODULAR,3 SMA CONN	80009	
-8	211-A151-XX			4	SCREW,MACHINE;M2X6MM L,PNH,STLZN-C,CROSS REC, W/KOGATA-PLAIN&SPLIT WSHR	80009	
-9	407-A697-XX			1	BRACKET:SW&YTF,A5052P	80009	
-10	174-B978-XX			1	CA ASSY,SP,ELEC:16,26AWG,7CM,RIBBON,W/HLDR	80009	
-11	211-A151-XX			6	SCREW,MACHINE;M2X6MM L,PNH,STLZN-C,CROSS REC, W/KOGATA-PLAIN&SPLIT WSHR	80009	
-12	174-C009-XX			1	CA ASSY,SP,ELEC:5,26AWG,35CM L,RIBBON,W/HLDR	80009	
-13	671-B254-XX			1	CIRCUIT BD ASSY:A100 INTER CONNECTION,389-B189-XX WIRED	80009	
-14	174-C008-XX			2	CA ASSY,SP,ELEC:4,26AWG,25CM L,RIBBON,W/HLDR	80009	
-15	174-C013-XX			1	CABLE ASSY,RF:50OHM,COAX,25CM L,1.5D-QEW, SMB-L TO SMA-L	80009	
-16	348-0949-XX			1	GROMMET,PLASTIC:BLACK,RING,15MM ID	80009	
-17	174-B952-XX			1	CA ASSY,RF:50OHM,SEMI-RIGID,W109,STEP ATT TO A310	80009	

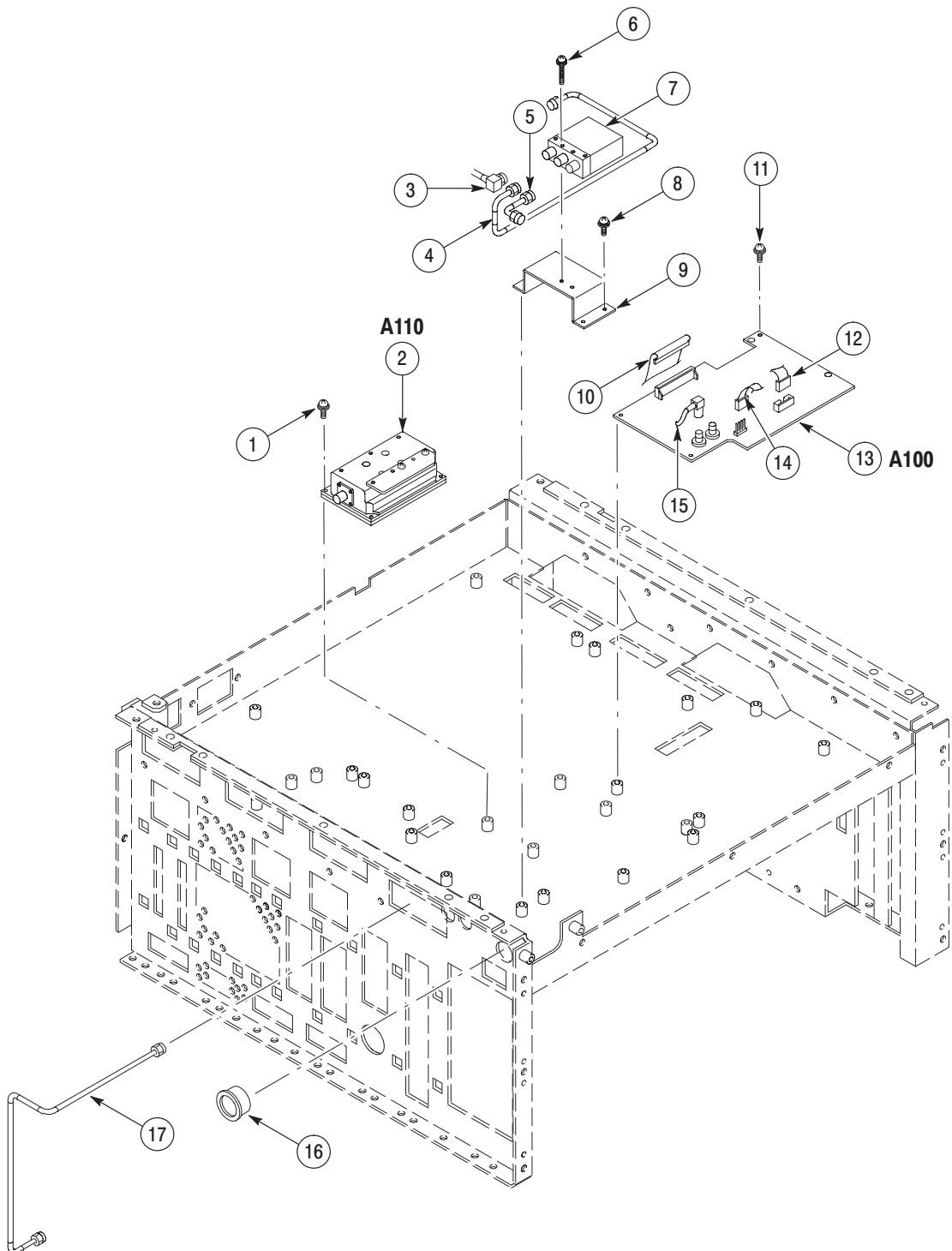

Figure 10-9: Bottom modules - RF1 (RSA2203A)

Replaceable parts list

Fig. & index number	Tektronix part number	Serial No. effective	Serial No. discont'd	Qty	Name & description	Mfr. code	Mfr. part number
10-10					FOR RSA2208A ONLY		
-1	174-C038-XX			1	CABLE ASSY,RF:SEMI-RIGID,W121,ATT TO SW	80009	
-2	211-A273-XX			4	SCREW,MACHINE:M2.5X18 L,PNH,STL,NI PL,CROSS REC, W/FLAT(KOGATA)&LOCK WASHER	80009	
-3	148-A079-XX			1	RELAY,ARMATURE;SPDT,SINGLE SIDE STABLE; RF COAXIAL,18GHZ,COIL 12VDC,70MA,1.53H X 1.34W X 0.52D;ARD10012C03,MODULAR,3 SMA CONN	80009	
-4	174-C039-XX			1	CABLE ASSY,RF:SEMI-RIGID,W122,SW TO FINE ATT	80009	
-5	174-C040-XX			1	CABLE ASSY,RF:SEMI-RIGID,W123,SW TO YTF	80009	
-6	386-A874-XX			1	PLATE,BASE:RF-1,AL T=1.6	80009	
-7	174-B944-XX			1	CA ASSY,RF:50OHM,SEMI-RIGID,0.085IN,SMA-SMA,W101, WCA280A,WAKA SEISAKUSHO	80009	
-8	174-C037-XX			1	CABLE ASSY,RF:SEMI-RIGID,W120,SW TO ATT	80009	
-9	211-0661-XX			4	SCREW,MACHINE;4-40X0.25,PNH,STL,CD PL,POZ,SEMS	80009	
-10	211-A151-XX			4	SCREW,MACHINE:M2.5X6MM L,PNH,STL,ZN-C, CROSS REC,W/KOGATA-PLAIN&SPLIT WSHR	80009	
-11	119-A960-XX			2	ATTENUATOR,FXD:3DB,DC-8GHZ,50 OHM,1W,SMA CONN	80009	
-12	671-B190-XX			1	CIRCUIT BD ASSY:A150 YTF I/F,389-B192-XX WIRED	80009	
-13	119-A864-XX			1	YTF UNIT;YIG FILTER,3.5-8GHZ,4STAGE,30MHZ BW, 5DB LOSS,20MHZ/MA,30.5 SQX X 14.2H,SMA	80009	
-14	407-A725-XX			1	BRACKET:YTF,AL T=1.6	80009	
-15	211-A152-XX			2	SCREW,MACHINE:M2.5X8MM L,PNH,STL,NI PL,CROSS REC, W/KOGATA-PLAIN&SPLIT WSHR	80009	
-16	211-0871-XX			2	SCREW,MACHINE:M3X6MM L,PNH,STL,MFZN-C, CROSS REC W/FLAT&LOCK WASHER	80009	
-17	211-A151-XX			3	SCREW,MACHINE:M2.5X6MM L,PNH,STL,ZN-C, CROSS REC,W/KOGATA-PLAIN&SPLIT WSHR	80009	
-18	407-A726-XX			1	BRACKET:ATT,AL T=1.6	80009	
-19	119-B186-XX			1	ATTENUATOR:MODULE,STEP ATT,0-70DB,10DB STEP, DC-8GHZ,50 OHM,COIL 24V 0.72A	80009	
-20	174-B978-XX			1	CA ASSY,SP,ELEC:16,26AWG,7CM,RIBBON,W/HLDR	80009	
-21	211-0871-XX			6	SCREW,MACHINE;M3X6MM L,PNH STL,ZN PL,CROSS REC, W/FLAT&LOCK WASHER	80009	
-22	174-C009-XX			1	CA ASSY,SP,ELEC:5,26AWG,35CM L,RIBBON,W/HLDR	80009	
-23	671-B187-XX			1	CIRCUIT BD ASSY:A100 INTER CONNECTION,389-B189-XX WIRED	80009	
-24	174-C008-XX			2	CA ASSY,SP,ELEC:4,26AWG,25CM L,RIBBON,W/HLDR	80009	
-25	174-C013-XX			1	CABLE ASSY,RF:50OHM,COAX,25CM L,1.5D-QEW, SMB-L TO SMA-L	80009	
-26	348-0949-XX			1	GROMMET,PLASTIC:NYLON,BLACK,RING,15MM ID	80009	
-27	174-B949-XX			1	CA ASSY,RF:50OHM,SEMI-RIGID,W106,FINE ATT TO SW	80009	
-28	174-B948-XX			1	CA ASSY,RF:50OHM,SEMI-RIGID,W105,YTF TO A310	80009	

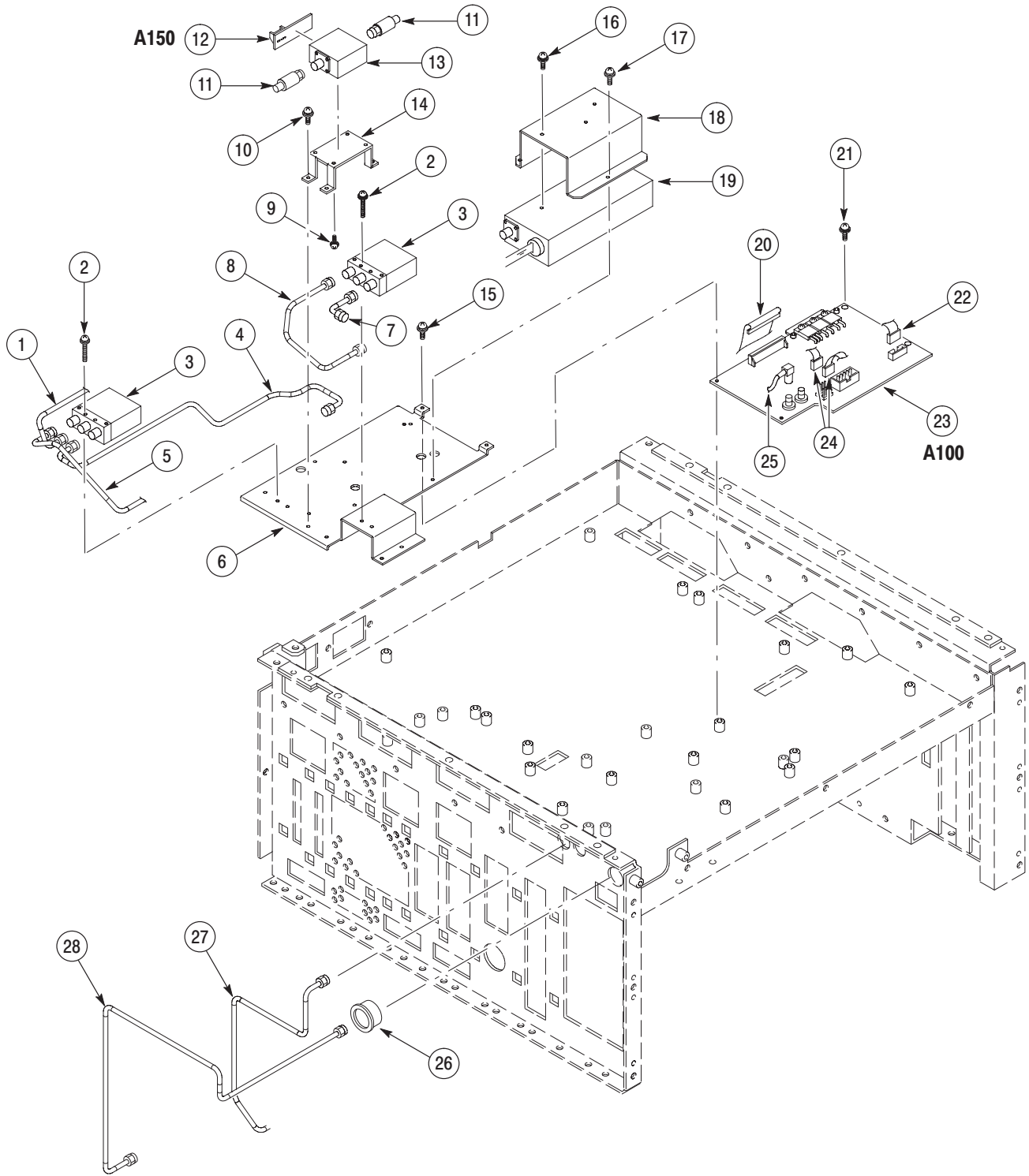

Figure 10-10: Bottom modules - RF1 (RSA2208A)

Replaceable parts list

Fig. & index number	Tektronix part number	Serial No. effective	Serial No. discont'd	Qty	Name & description	Mfr. code	Mfr. part number
10-11							
-1	211-1028-XX			2	SCREW,MACHINE:M4X8MM L,PNH,STL,ZN-C PL, CROSS REC W/FLAT&LOCK WASHER	80009	
-2	348-1761-XX			2	GASKET SHIELD:CONDUCTIVE URETHAN FOAM, 2MM X 4MM,140 MM L,W/ADHESIVE	80009	
-3	174-B994-XX			1	CA ASSY,SP,ELEC:24,AWG28,20CM L,DDK 57FE TO 3M, 2.54MM,GPIB	80009	
-4	220-0194-XX			1	NUT,PLATE:STL	80009	
-5	174-4102-XX			2	CA ASSY,RF:50OHM,1.5D-2W,10CM L,SMB/L-SMB/L	80009	
-6	174-B980-XX			2	CABLE ASSY,RF:50OHM,COAX,17CM L,1.5D-QEW, SMB-L TO SMB-L	80009	
-7	348-1762-XX			4	GASKET SHIELD:CONDUCTIVE URETHAN FOAM, 2MM X 4MM,180 MM L,W/ADHESIVE	80009	
-8	211-A151-XX			16	SCREW,MACHINE:M2.5X6MM L,PNH,STL,ZN-C, CROSS REC,W/KOGATA-PLAIN&SPLIT WSHR	80009	
-9	131-6607-XX			4	CONN,RF:BNC/F TO SMB/F,50OHM,PANEL MOUNT	80009	
-10	386-A865-XX			1	PLATE BLANK:BNC CONNECTOR	80009	
-11	333-A445-XX			1	PANEL,REAR:WCA230A&WCA280A,AL	80009	
-12	407-A679-XX			1	BRACKET:BOARD GUIDE	80009	
-13	351-A169-XX			2	GUIDE,CKT BD:NYLON BLACK,19MM L	80009	
-14	351-A168-XX			8	GUIDE,CKT BD:NYLON BLACK,100MM L	80009	
-15	407-A680-XX			1	BRACKET:GUIDE,PC BOARD	80009	
-16	351-A168-XX			10	GUIDE,CKT BD:NYLON BLACK,100MM L	80009	
-17	351-A169-XX			2	GUIDE,CKT BD:NYLON BLACK,19MM L	80009	
-18	211-1028-XX			2	SCREW,MACHINE:M4X8MM L,PNH,STL,ZN-C PL, CROSS REC W/FLAT&LOCK WASHER	80009	
-19	441-A293-XX			1	CHASSIS,MAIN:WCA230A/280A	80009	
-20	211-1028-XX			10	SCREW,MACHINE:M4X8MM L,PNH,STL,ZN-C PL, CROSS REC W/FLAT&LOCK WASHER	80009	

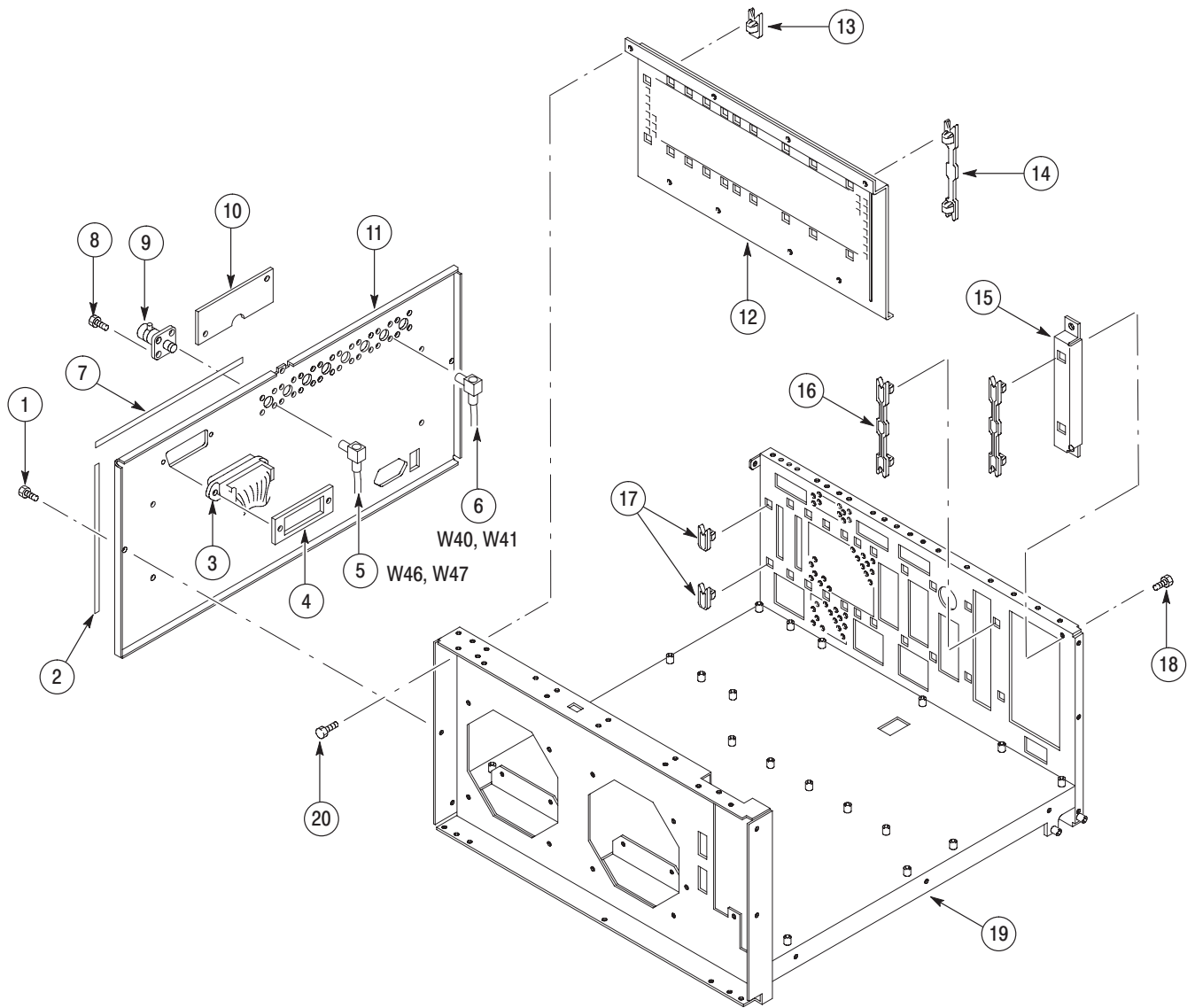

Figure 10-11: Chassis modules - 1

Replaceable parts list

Fig. & index number	Tektronix part number	Serial No. effective	Serial No. discont'd	Qty	Name & description	Mfr. code	Mfr. part number
10-12							
-1	211-A004-XX			4	SCREW,MACHINE:M4X10MM L,PNH,STL,ZN-C,CROSS REC, W/FLAT&LOCK WASHER	80009	
-2	211-0871-XX			2	SCREW,MACHINE:M3X6MM L,PNH,STL,MFZN-C, CROSS REC,W/FLAT&LOCK WASHER	80009	
-3	407-4990-XX			1	BRACKET,SHIELD:SIDE,AL	80009	
-4	348-A143-XX			3	GASKET,SHIELD:FINGER TYPE,15.2MM W X 5.6MM H X 7.2MM L	80009	
-5	407-A681-XX			1	BRACKET:SIDE PANEL	80009	
-6	348-1644-XX			6	SHLD GASKET,ELEC:CONDUCTIVE URETHANE FOAM W/ADHESIVE TAPE	80009	
-7	407-A732-XX			1	BRACKET,STOPPER:GASKET,UPPER,AL	80009	
-8	213-A248-XX			4	SCREW,MACHINE:M4X35 L,PNH,STL,ZN-C,CROSS REC, W/FLAT(MIGAKI)&LOCK WASHER	80009	
-9	119-B161-XX			2	FAN,TUBEAXIAL:12VDC,2W,2000RPM,31DB,W/CONNECTOR	80009	
-10	348-A158-XX			10.5 cm	SHLD GSKT ELEC:CONDUCTIVE URETHANE FOAM,1X4 W/ADHESIVE	80009	
-11	348-A158-XX			10 cm	SHLD GSKT ELEC:CONDUCTIVE URETHANE FOAM,1X4 W/ADHESIVE	80009	
-12	348-A143-XX			6	GASKET,SHIELD:FINGER TYPE,15.2MM W X 5.6MM H X 7.2MM L	80009	

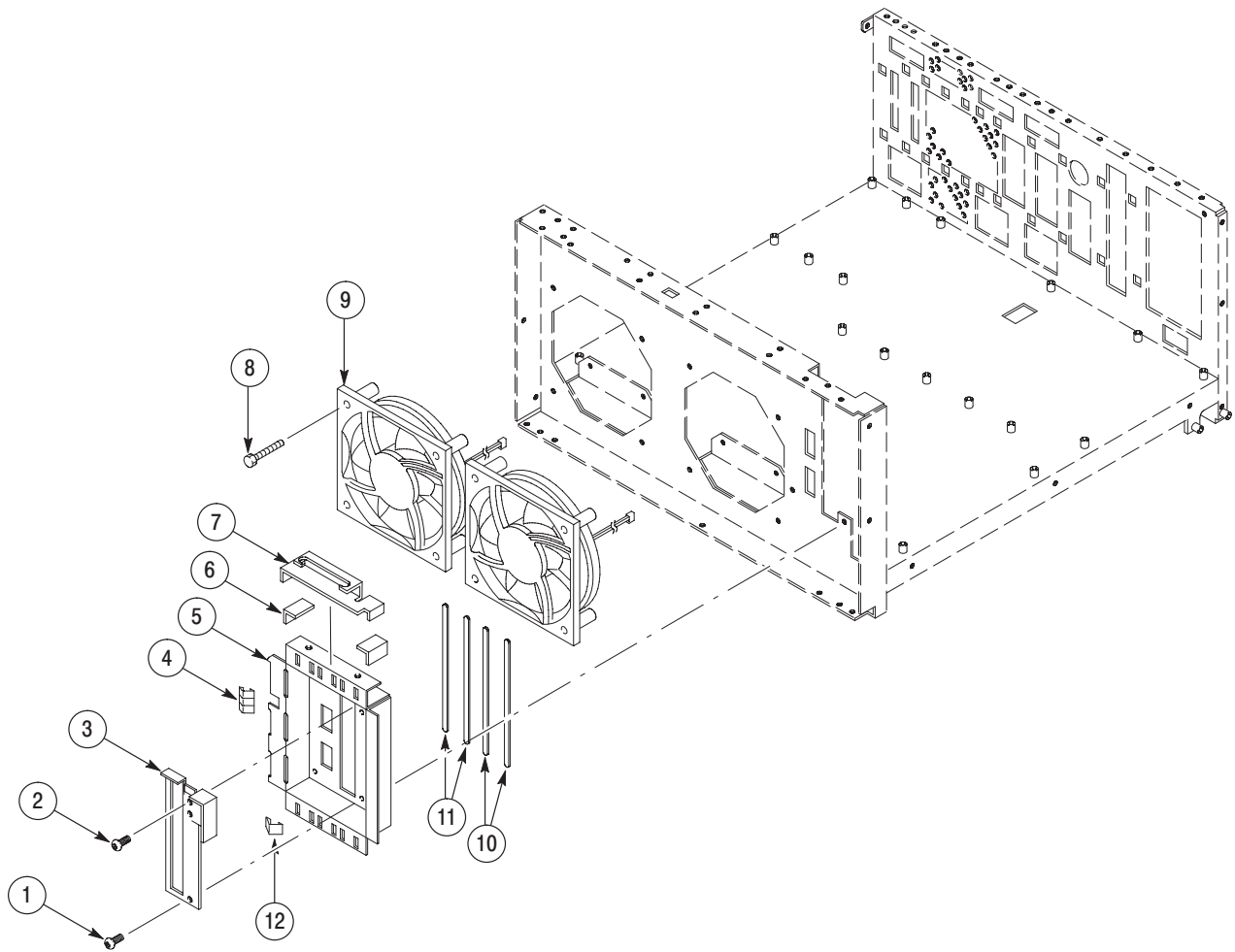

Figure 10-12: Chassis modules - 2

Replaceable parts list

Fig. & index number	Tektronix part number	Serial No. effective	Serial No. discont'd	Qty	Name & description	Mfr. code	Mfr. part number
10-13							
-1	211-A039-XX			2	SCREW,MACHINE:M4X14MM L,PNH,STL,ZN PL,CROSS REC, W/FLAT&LOCK WASHER	80009	
-2	407-A694-XX			2	BRACKET,REAR:RACK MOUNT	80009	
-3	129-A137-XX			1	SPACER,POST:46.0MM L,M3 INT/EXT,STL,MFZN-C PL, 5.5MM HEX	80009	
-4	407-A695-XX			1	BRACKET:SHELD,SIDE PANEL	80009	
-5	211-0871-XX			2	SCREW,MACHINE:M3X6MM L,PNH,STL,ZN PL,CROSS REC, W/FLAT(7MM OD)&LOCK WASHER	80009	
-6	211-A039-XX			4	SCREW,MACHINE:M4X14MM L,PNH,STL,ZN PL,CROSS REC, W/FLAT&LOCK WASHER	80009	
-7	211-A004-XX			4	SCREW,MACHINE:M4X10MM L,PNH,STL,ZN-C,CROSS REC, W/FLAT&LOCK WASHER	80009	
-8	211-1028-XX			4	SCREW,MACHINE:M4X8MM L,PNH,STL,ZN-C PL, CROSS REC,W/FLAT&LOCK WASHER	80009	
-9	407-A699-XX			1	BRACKET,SUPPORT:FRONT,LEFT	80009	
-10	367-0492-XX			2	HANDLE:BOW,60MM L,SST	80009	
-11	211-A132-XX			4	SCREW,MACHINE:M5X16MM L,PNH,STL,ZN PL,CROSS REC, W/FLAT&LOCK WASHER	80009	
-12	407-A700-XX			1	BRACKET,SUPPORT:FRONT,RIGHT	80009	

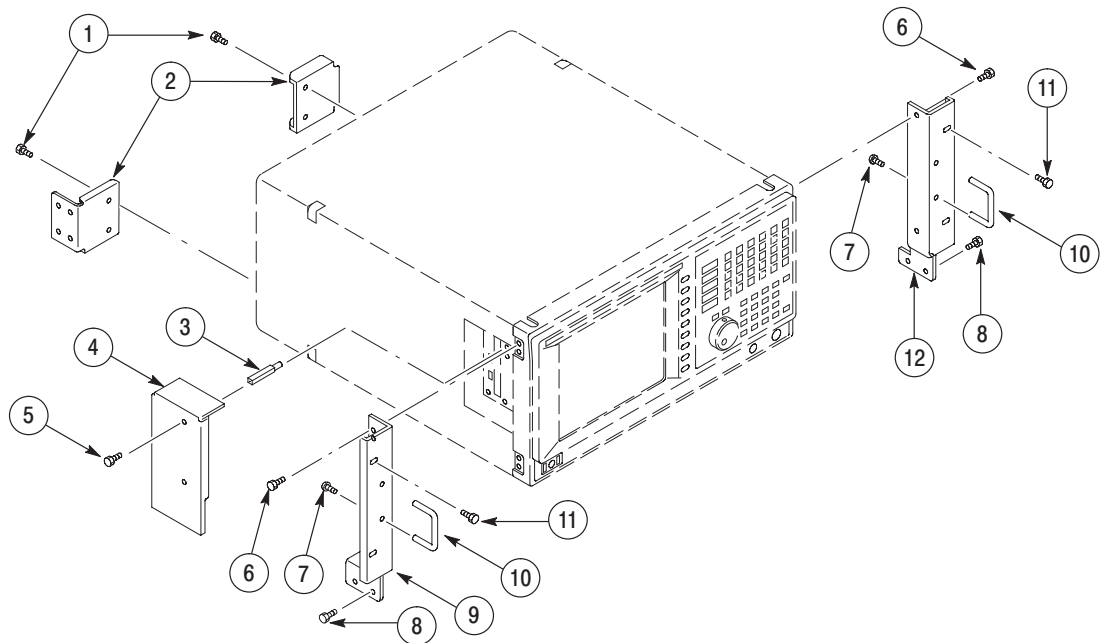

Figure 10-13: Rackmount - 1

Replaceable parts list

Fig. & index number	Tektronix part number	Serial No. effective	Serial No. discont'd	Qty	Name & description	Mfr. code	Mfr. part number
10-14							
-1	174-C016-XX			1	CA ASSY,SP,ELEC:8,AWG26,40CM L,PLUG&JACK, PANEL MOUNT,W SHIELD,LAN	80009	
-2	211-0871-XX			1	SCREW,MACHINE:M3X6MM L,PNH,STL,ZN PL,CROSS REC, W/FLAT(7MM OD)&LOCK WASHER	80009	
-3	407-A701-XX			1	BRACKET:LAN CONNECTOR	80009	
-4	348-A145-XX			3 CM	SHLD GSKT,ELEC:CONDUCTIVE URETHANE FOAM, W4.8 X H5.1,W/ADHESIVE TAPE	80009	
-5	174-C015-XX			2	CA ASSY,SP,ELEC:4,AWG26,40CM L,PLUG&JACK, PANEL MOUNT,W SHIELD,USB	80009	
-6	407-A705-XX			2	BRACKET SUPPORT:USB,AL	80009	
-7	348-A146-XX			6.8 CM	GASKET,SHIELD:CONDUCTIVE URETHANE FOAM,6X6	80009	
-8	436-A016-XX			1	DRAWER:RACK MOUNT,WCA230A/280A	80009	
-9	344-0557-XX			2	CLIP,CABLE:WIRE SADDLE,11.1MMX14.7MM,66-NYLON		
-10	211-1028-XX			4	SCREW,MACHINE:M4X8MM L,PNH,STL,ZN-C PL, CROSS REC,W/FLAT&LOCK WASHER	80009	
-11	211-8800-XX			12	SCREW,MACHINE:M4X8MM L,BDGH,STL,ZN-C	80009	
-12	211-8800-XX			8	SCREW,MACHINE:M4X8MM L,BDGH,STL,ZN-C	80009	
-13	211-A039-XX			4	SCREW,MACHINE:M4X14MM L,PNH,STL,ZN PL,CROSS REC, W/FLAT&LOCK WASHER	80009	
-14	386-A866-XX			4	PLATE:NUT	80009	
-15	220-0193-XX			8	NUT,PLAIN,HEX:M4X7MM HEX,STL,ZN-C	80009	
-16	407-A708-XX			2	BRACKET:SLIDE RAIL MT	80009	
-17	407-A052-XX			1	BRACKET:(5517)	80009	
-18	351-A167-XX			2	GUIDE,SLIDE:RACKMOUNT,L AND R, 457.2MM SLIDE LENGTH	80009	
-19	212-A012-XX			3	SCREW,MACHINE:M4X8MM L,TRUSS HD,STL,NI PL, CROSS REC	80009	
-20	333-A447-XX			1	PANEL,FRONT:RACK MOUNT	80009	
-21	211-A044-XX			4	SCREW,MACHINE:M3X10MM L,FLH,STL,ZN PL,CROSS REC	80009	
-22	211-1040-XX			2	SCREW,MACHINE:M3X8MM L,FLH,STL,ZN-C,CROSS REC	80009	

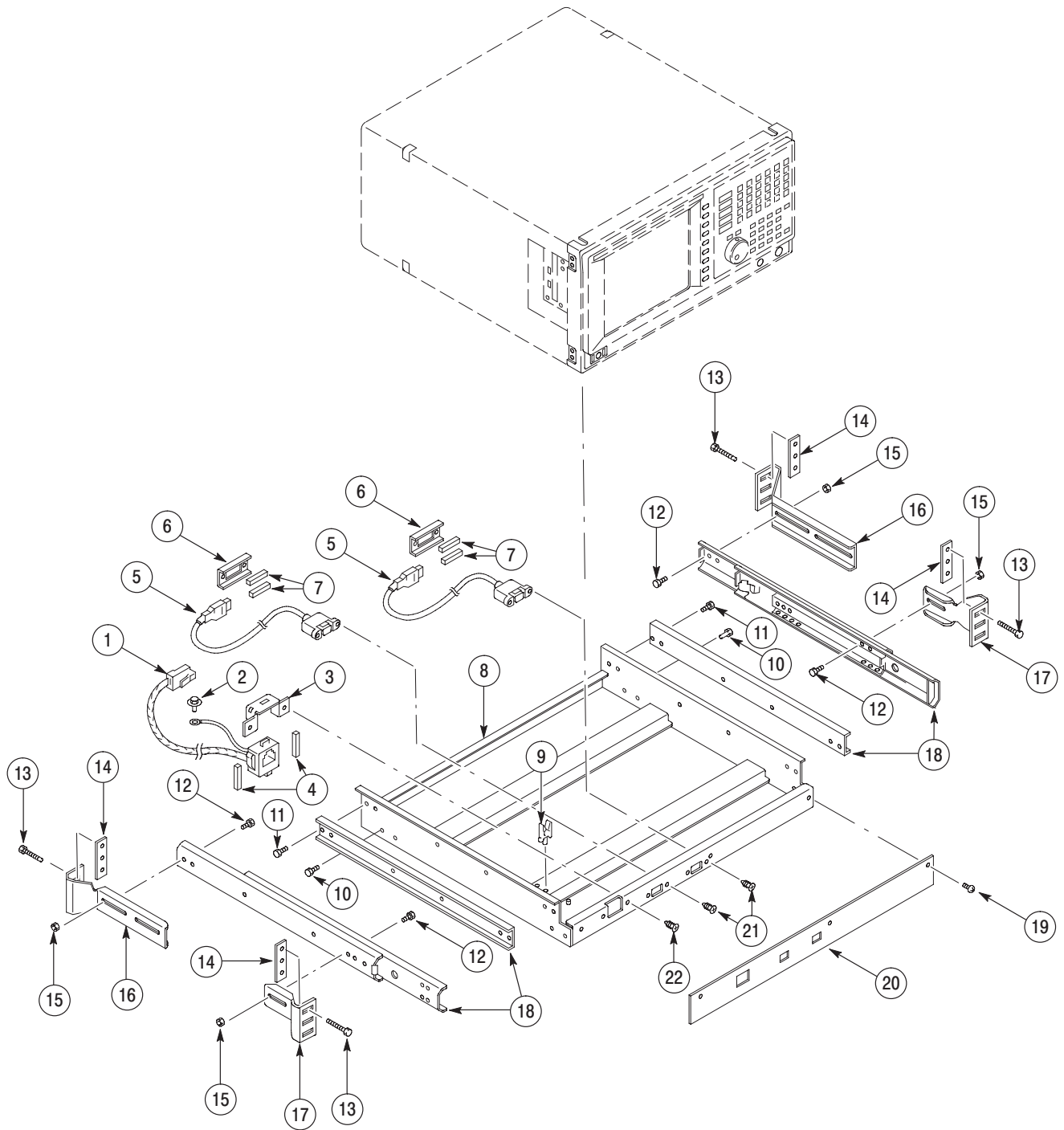

Figure 10-14: Rackmount - 2

Replaceable parts list

Fig. & index number	Tektronix part number	Serial No. effective	Serial No. discont'd	Qty	Name & description	Mfr. code	Mfr. part number
STANDARD ACCESSORIES							
	-----			1	CABLE ASSY,PWR;3,18 AWG,92.0 L,TAN,60 DEGREE C, MC-6-3C/G X RIGHT ANGLE BME,10A/125V; SAFETY CONTROLLED (STANDARD CABLE - SEE FIG 10-1-14)	80009	
	161-0104-06			1	CABLE ASSY,PWR;3,1.0MM SQ,250V/10A,2.5 METER, RTANG,IEC320,RCPT,EUROPEAN,SAFETY CONTROLLED (OPTION A1 - EUROPEAN)	S3109	
	161-0104-07			1	CABLE ASSY,PWR;3,1.0MM SQ,250V/10A,2.5 METER, RTANG,IEC320,RCPT X 13A,FUSED,UK PLUG,(13A FUSE), UNITED KINGDOM,SAFETY CONTROLLED (OPTION A2 - UNITED KINGDOM)	S3109	
	161-0104-05			1	CABLE ASSY,PWR;3,1.0MM SQ,250V/10A,2.5 METER, RTANG,IEC320,RCPT,AUSTRALIA,SAFETY CONTROLLED (OPTION A3 - AUSTRALIAN)	S3109	
	161-0104-08			1	CABLE ASSY,PWR;3,18 AWG,250/10A,98.0 L,RTANG, IEC320,RCPT X STR,NEMA 6-15P,US,SAFETY CONTROLLED (OPTION A4 - NORTH AMERICAN)	S3109	
	161-0167-00			1	CABLE ASSY,PWR;3,0.75MM SQ,250V/10A,2.5 METER, RTANG,IEC320,RCPT,SWISS,NO CORD GRIP, SAFETY CONTROLLED (OPTION A5 - SWITZERLAND)	S3109	ORDER BY DESC
	161-A005-00			1	CABLE ASSY,PWR;JAPANESE T MARK, SAFETY CONTROLLED (OPTION A6 - JAPANESE)	80009	
	161-0306-00			1	CABLE ASSY,PWR;3,1.0MM SQ,250V/10A,2.5 METER, RTANG,IEC320,RCPT,3C CERTIFICATION,CHINA; SAFETY CONTROLLED (OPTION A10 - CHINA)	80009	
	103-0045-XX			1	ADPTR,N,ELEC:FEMALE BNC TO MALE N	80009	
	200-A524-XX			1	COVER,FRONT:WCA230A/280A	80009	
	071-1334-XX			1	MANUAL,TECH:USER,ENGLISH VERSION (RSA2203A/RSA2208A)	80009	
	071-1336-XX			1	MANUAL,TECH:PROGRAMMER,ENGLISH VERSION (RSA2203A/RSA2208A)	80009	
OPTIONAL ACCESSORIES							
	119-B145-XX			1	POINTER ASSY:OPTICAL MOUSE,USB	80009	
	119-B146-XX			1	KEYBOARD:USB	80009	
	071-1337-XX			1	MANUAL,TECH:SERVICE,ENGLISH VERSION (RSA2203A/RSA2208A)	80009	